



YAMAHA

GENUINE

PARTS CATALOGUE

GOLF CAR

REAR SHOCKS

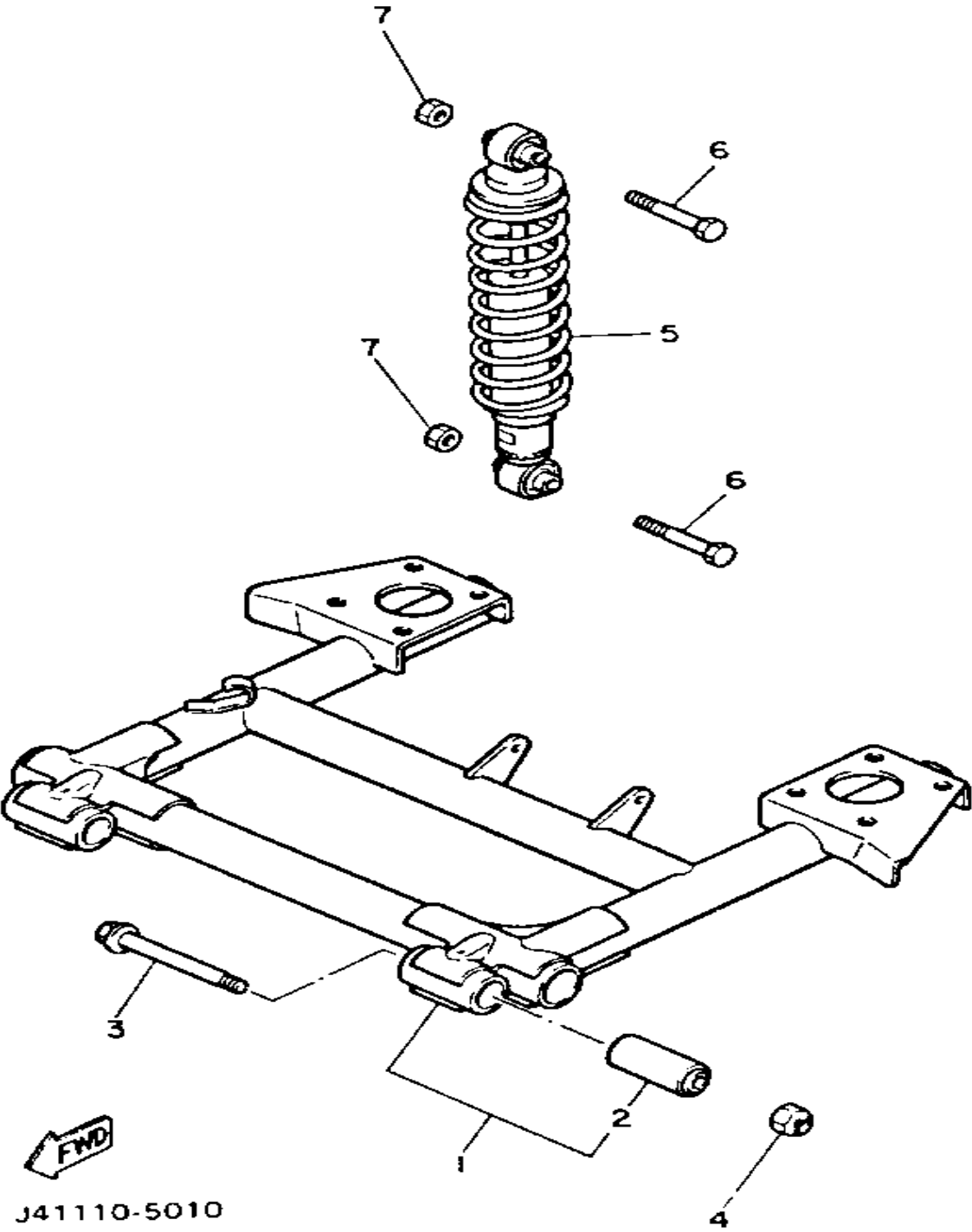

Ref. No.	Part Number	Description	Qty	Remarks
1	J56-F2110-W0-00	REAR ARM COMP. (J56-F2110-00-00)	1	
2	J10-22123-00-00	. BUSH 1	2	
3	90105-10359-00	BOLT, WASHER BASED	2	
4	90185-10115-00	NUT, SELF-LOCKING	2	
5	JG6-F2210-00-00	SHOCK ABSORBER ASSEMBLY, REAR	2	
6	97012-10050-00	BOLT (97002-10050-00)	4	
7	95601-10100-00	NUT, U (95602-10100-00)	4	

FRAME

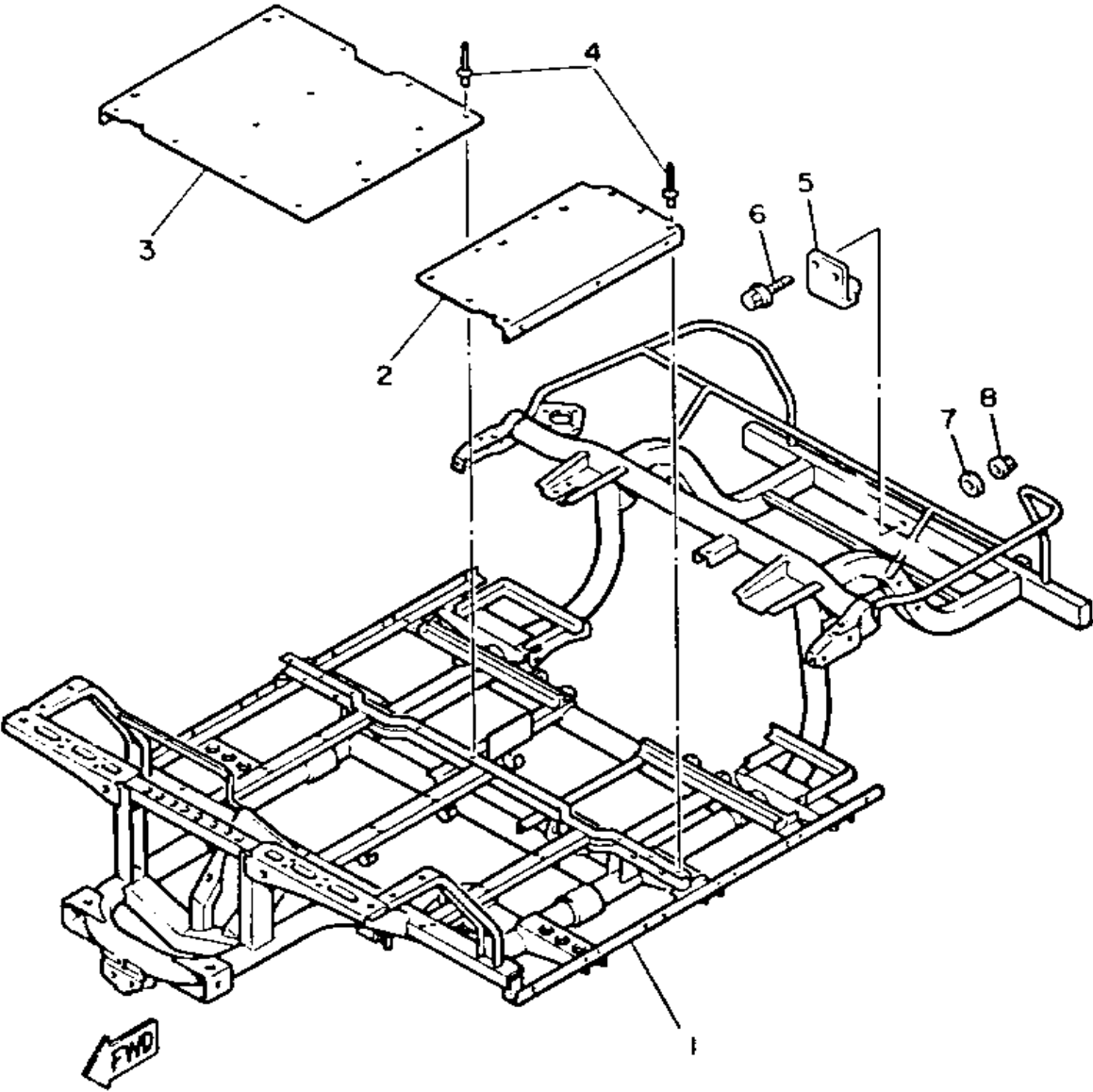

J41110-5021

Ref. No.	Part Number	Description	Qty	Remarks
1	J56-F2501-00-00	FRAME COMP. (J41-22501-01)	1	
2	J55-F2571-00-00	PANEL 1	1	
3	J55-F2572-00-00	PANEL 2	1	
4	90267-40054-00	RIVET, BLIND	20	
5	ABA-JF286-00-00	REAR HITCH	1	
6	95811-08050-00	BOLT, FLANGE (95812-08050)	2	
7	90201-08730-00	WASHER, PLATE	2	
8	95701-08500-00	NUT, FLANGE	2	

FRONT SUSPENSION - WHEEL

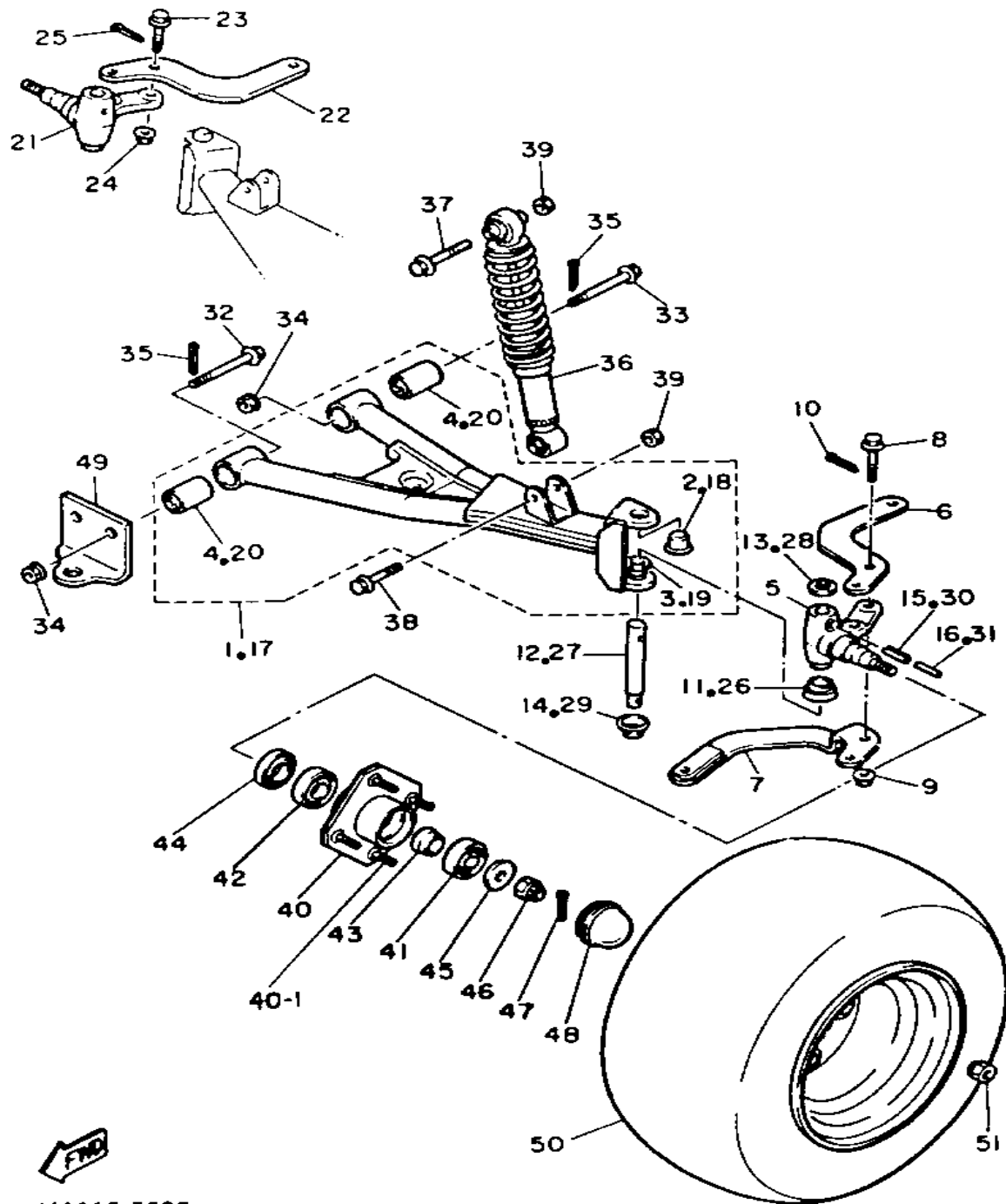

J41110-5030

Ref. No.	Part Number	Description	Qty	Remarks
1	J38-23507-01-00	FRONT LOWER ARM SUB-ASS'Y (L.H) (J38-23507-00)	1	
2	90338-17225-00	. PLUG	1	
3	90386-15139-00	. BUSH	1	
4	J38-23526-00-00	. BUSH	2	
5	J38-23511-01-00	KNUCKLE, STEERING 1	1	
6	J38-23512-02-00	ARM, KNUCKLE 1	1	
7	ABA-JF288-00-00	ARM, STEERING (J41-23532-00)	1	
8	90105-10366-00	BOLT, WASHER BASED	2	
9	90185-10115-00	NUT, SELF-LOCKING	2	
10	91401-25020-00	PIN, COTTER	2	
11	J38-23527-00-00	SEAL, DUST	1	
12	J38-23516-00-00	PIN, STEERING KNUCKLE	1	
13	90201-156J2-00	WASHER, PLAIN	1	
14	J38-23528-00-00	SEAL, DUST	1	
15	91609-60028-00	PIN, SPRING	1	
16	91609-35028-00	PIN, SPRING	1	
17	J38-23508-01-00	FRONT LOWER ARM SUB-ASS'Y (R.H) (J38-23508-00)	1	
18	90338-17225-00	. PLUG	1	
19	90386-15139-00	. BUSH	1	
20	J38-23526-00-00	. BUSH	2	
21	J38-23521-01-00	KNUCKLE, STEERING 2	1	
22	J38-23512-02-00	ARM, KNUCKLE 1	1	
23	90105-10360-00	BOLT, FLANGE	2	
24	90185-10115-00	NUT, SELF-LOCKING	2	
25	91401-25020-00	PIN, COTTER	2	
26	J38-23527-00-00	SEAL, DUST	1	
27	J38-23516-00-00	PIN, STEERING KNUCKLE	1	

CONTINUED ON NEXT FRAME ►

FRONT SUSPENSION - WHEEL

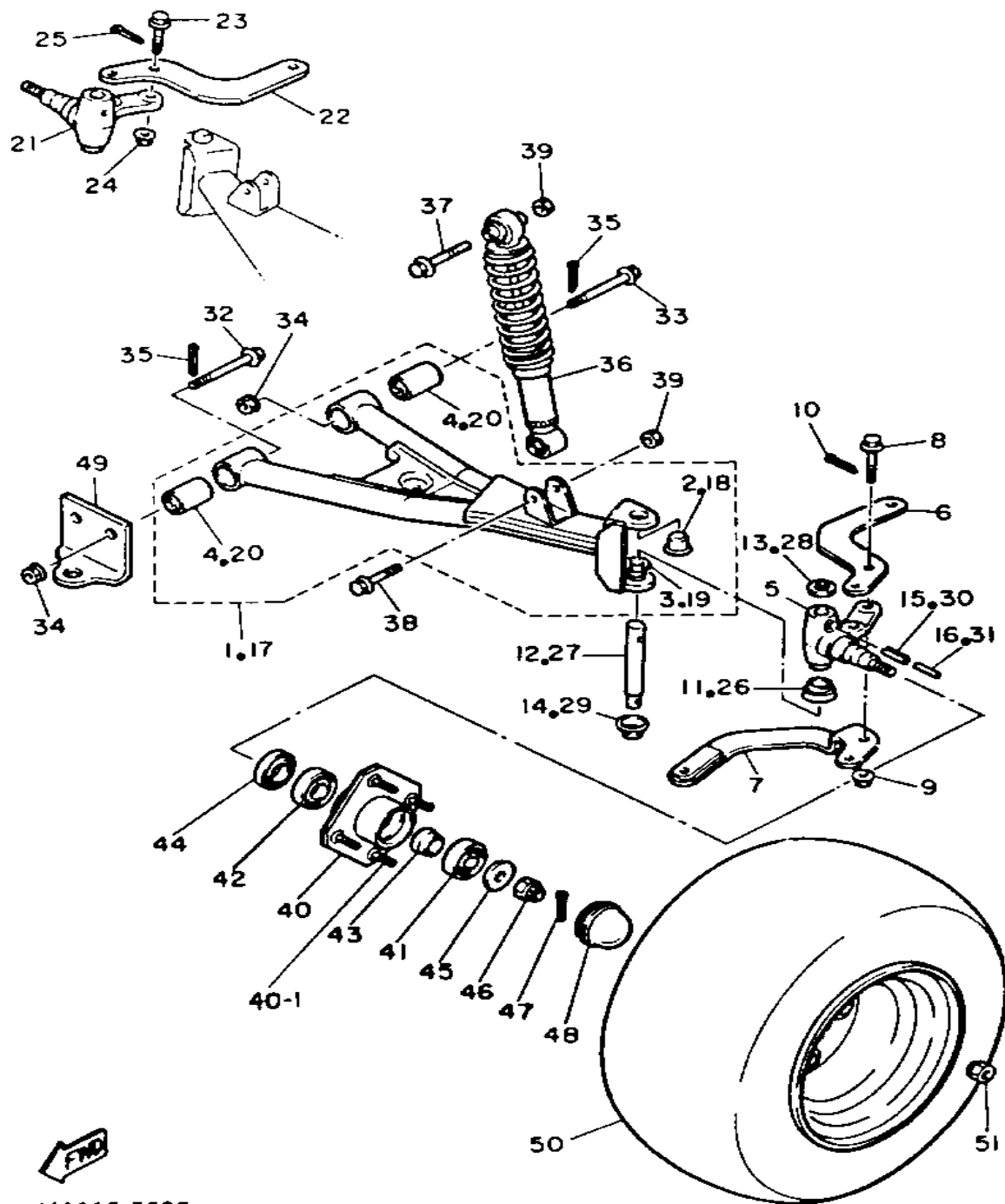

J41110-5030

Ref. No.	Part Number	Description	Qty	Remarks
28	90201-156J2-00	WASHER, PLAIN	1	
29	J38-23528-00-00	SEAL, DUST	1	
30	91609-60028-00	PIN, SPRING	1	
31	91609-35028-00	PIN, SPRING	1	
32	90105-10358-00	BOLT, WASHER BASED	2	
33	90105-10357-00	BOLT, FLANGE	2	
34	90185-10115-00	NUT, SELF-LOCKING	4	
35	91401-25020-00	PIN, COTTER	4	
36	J41-23350-00-00	SHOCK ABSORBER ASS'Y	2	
37	97002-10065-00	BOLT	2	
38	97012-10050-00	BOLT (97002-10050-00)	2	
39	95601-10100-00	NUT, U (95602-10100-00)	4	
40	J38-W2511-00-00	HUB, FRONT	2	
41	93306-20437-00	BEARING	2	
42	93306-00511-00	BEARING	2	
43	90387-241M7-00	COLLAR	2	
44	93102-30083-00	SEAL, OIL	2	
45	90209-32271-00	WASHER	2	
46	95601-14100-00	NUT, U (95602-14100-00)	2	
47	91401-25020-00	PIN, COTTER	2	
48	J17-25118-00-00	COVER, HUB DUST	2	
49	J41-23881-02-00	BRACKET 1 (J41-23881-01)	1	
50	J55-F5100-00-00	FRONT WHEEL ASSEMBLY	2	LM See Note
51	90179-12262-00	NUT	8	
40-1	90114-12003-00	. BOLT, RIBBED NECK	4	

STEERING

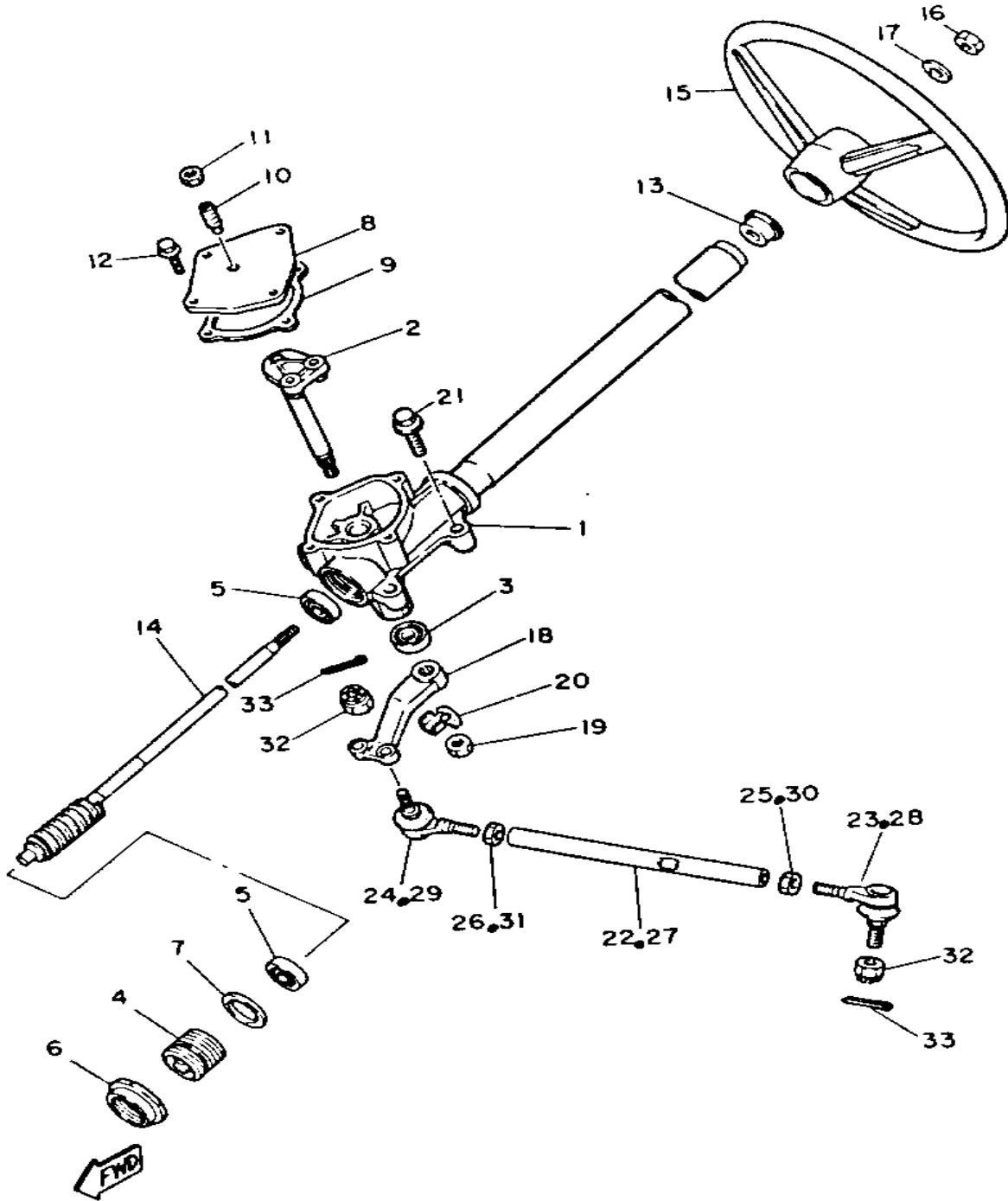

J41110-5040

Ref. No.	Part Number	Description	Qty	Remarks
1	J55-F3811-00-00	COLUMN, STEERING (J38-23811-00)	1	
2	J38-23816-00-00	ARM, PITMAN	1	
3	93102-22087-00	OIL SEAL	1	
4	J55-F3876-00-00	BOLT	1	
5	93332-00010-00	BEARING	2	
6	J10-23877-00-00	NUT	1	
7	J10-23444-00-00	WASHER	1	
8	J55-23818-00-00	COVER, STEERING	1	
9	J38-23462-00-00	SEAL, STEERING (J38-23462-01-00)	1	
10	J10-23459-00-00	BOLT	1	
11	90170-08024-00	NUT, HEX.	1	
12	95811-06020-00	BOLT, FLANGE	4	
13	J38-23814-00-00	HOLDER, HANDLE UPPER	1	
14	J10-23840-00-00	STEERING SHAFT	1	
15	J55-F3838-00-00	WHEEL, STEERING (J10-23838-00)	1	
16	90185-12119-00	NUT, SELF-LOCKING	1	
17	92990-12200-00	WASHER, PLAIN	1	
18	J38-23826-01-00	ARM, IDLER	1	
19	95701-16300-00	NUT, FLANGE	1	
20	90215-16161-00	WASHER, LOCK	1	
	90215-16252-00	WASHER, TONGUE	1	
21	95811-10050-00	BOLT, FLANGE (95812-10050-00)	4	
22	J38-23831-00-00	ROD, tie 0 1	1	101~ 018620
	J38-23831-02-00	ROD, TIE	1	621 ~
23	J38-23841-00-00	JOINT, universal 1 0 1	1	101~ 018620
	J38-23841-01-00	JOINT, UNIVERSAL 1	1	621~

CONTINUED ON NEXT FRAME ►

STEERING

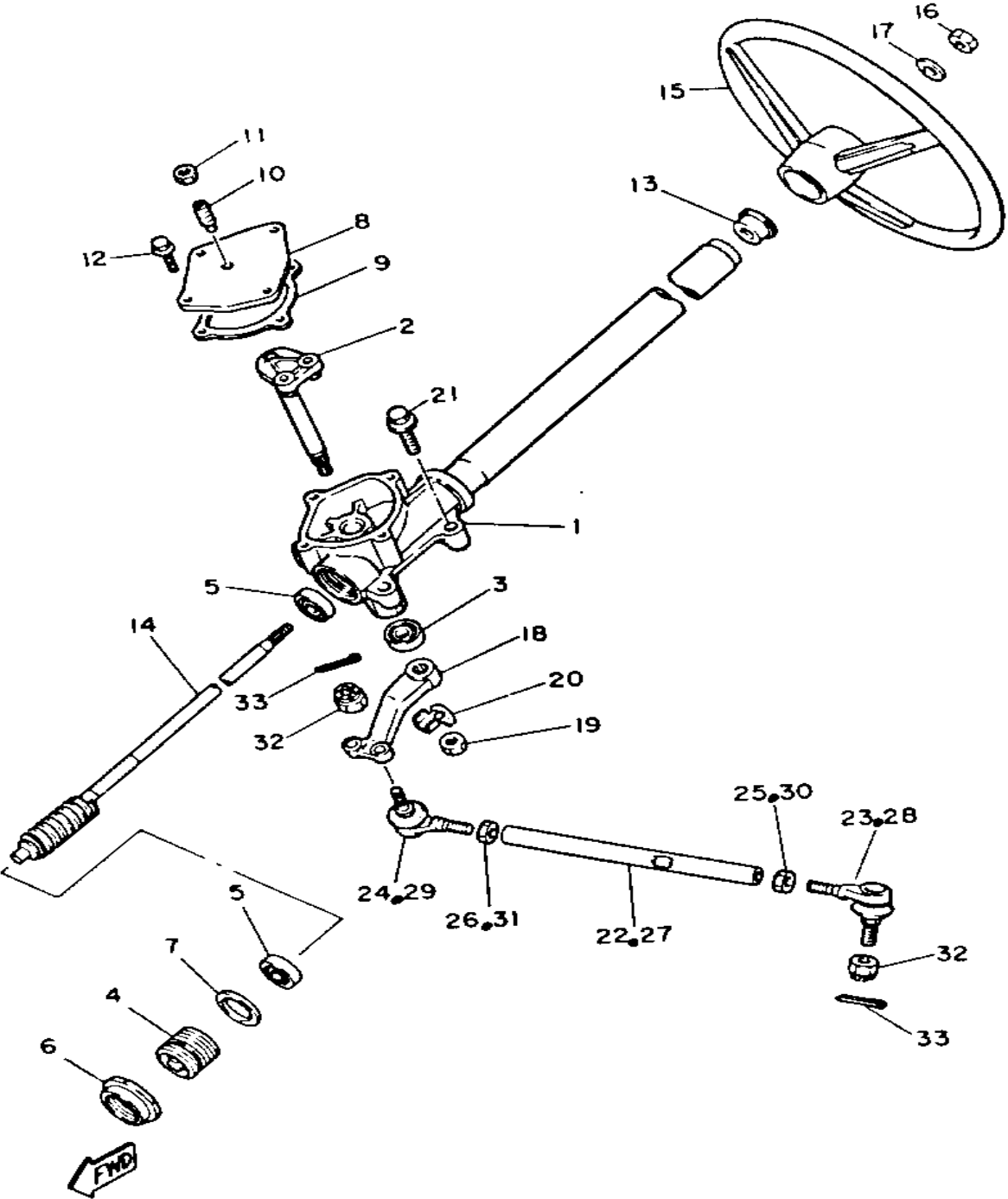

Ref. No.	Part Number	Description	Qty	Remarks
24	J38-23845-00-00	JOINT, universal 2 0 1	1	101~ 018620
	J38-23845-01-00	JOINT, UNIVERSAL 2	1	621~
25	90170-12055-00	NUT	1	621~
	95303-10700-00	NUT	1	101~ 018620
26	90170-10186-00	NUT	1	101~ 018620
	90170-12054-00	NUT	1	621 ~
27	J38-23837-00-00	ROD, tie 2 0 1	1	101~ 018620
	J38-23837-02-00	ROD, TIE 2	1	621 ~
28	J38-23841-00-00	JOINT, universal 1 0 1	1	101~ 018620
	J38-23841-01-00	JOINT, UNIVERSAL 1	1	621~
29	J38-23845-00-00	JOINT, universal 2 0 1	1	101~ 018620
	J38-23845-01-00	JOINT, UNIVERSAL 2	1	621~
30	90170-12055-00	NUT	1	621~
	95303-10700-00	NUT	1	101~ 018620
31	90170-10186-00	NUT	1	101~ 018620
	90170-12054-00	NUT	1	621~
32	95601-10100-00	NUT, U (95602-10100-00)	4	
33	91401-25020-00	PIN, COTTER	4	

J41110-5040

BRAKE

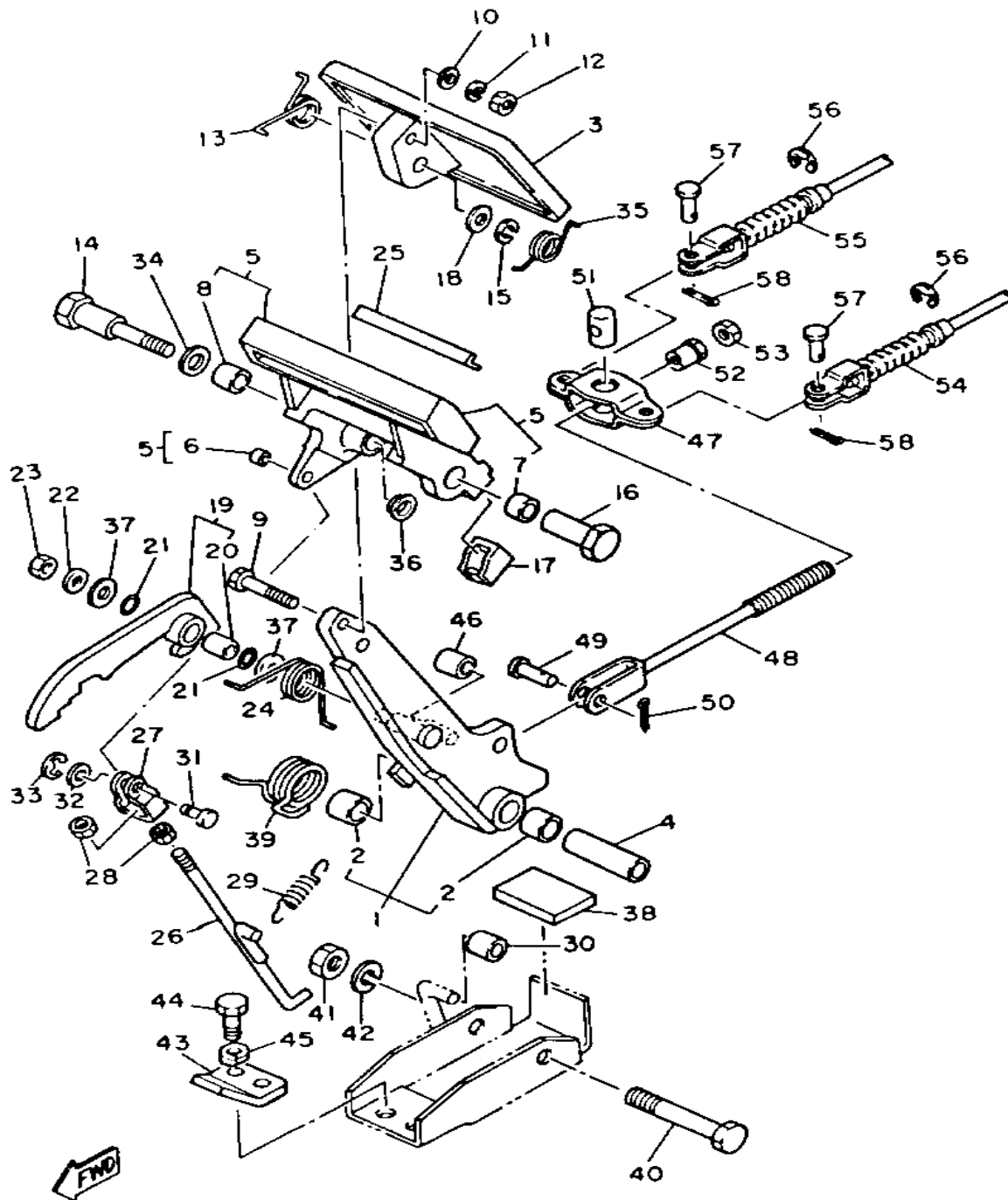

J41110-5050

Ref. No.	Part Number	Description	Qty	Remarks
1	92990-10600-00	. WASHER, PLATE	1	
	99080-07600-00	. CIRCLIP (E)	1	
	99999-01757-00	BRAKE ARM CMLPT (J17-27250-01)	1	
	J17-27250-02-00	. BRAKE ARM COMP.	1	
2	90384-14080-00	. BUSH, BIMETAL	2	
3	J10-27211-00-00	PEDAL, BRAKE	1	
4	90387-107F8-00	COLLAR	1	
5	99999-01799-00	PARKING PEDAL COMP. (J17-25670-00)	1	
	J17-25670-01-00	. PARKING PEDAL COMP.	1	
	J17-25679-01-00	. DAMPER	2	
6	90384-05163-00	. BUSH, BIMETAL	1	
7	90384-12164-00	. BUSH, BIMETAL	1	
8	90380-12051-00	. BUSH, SOLID	1	
9	90101-06555-00	BOLT, HEX.	1	
10	92990-06200-00	WASHER	1	
11	92995-06100-00	WASHER, SPRING	1	
12	95380-06600-00	NUT	1	
13	90508-23542-00	SPRING, TORSION	1	
14	90109-08669-00	BOLT	1	
15	92990-08100-00	WASHER	1	
16	90179-08378-00	NUT	1	
17	J17-25679-01-00	DAMPER	1	
18	92990-08200-00	WASHER, PLAIN	1	
19	J17-W2561-00-00	SECTOR, PARKING BRAKE ..	1	
20	90384-10162-00	. BUSH, BIMETAL	1	
21	J17-27221-00-00	SEAL, SHAFT	2	
22	90201-065F3-00	WASHER, PLATE	1	

CONTINUED ON NEXT FRAME ►

BRAKE

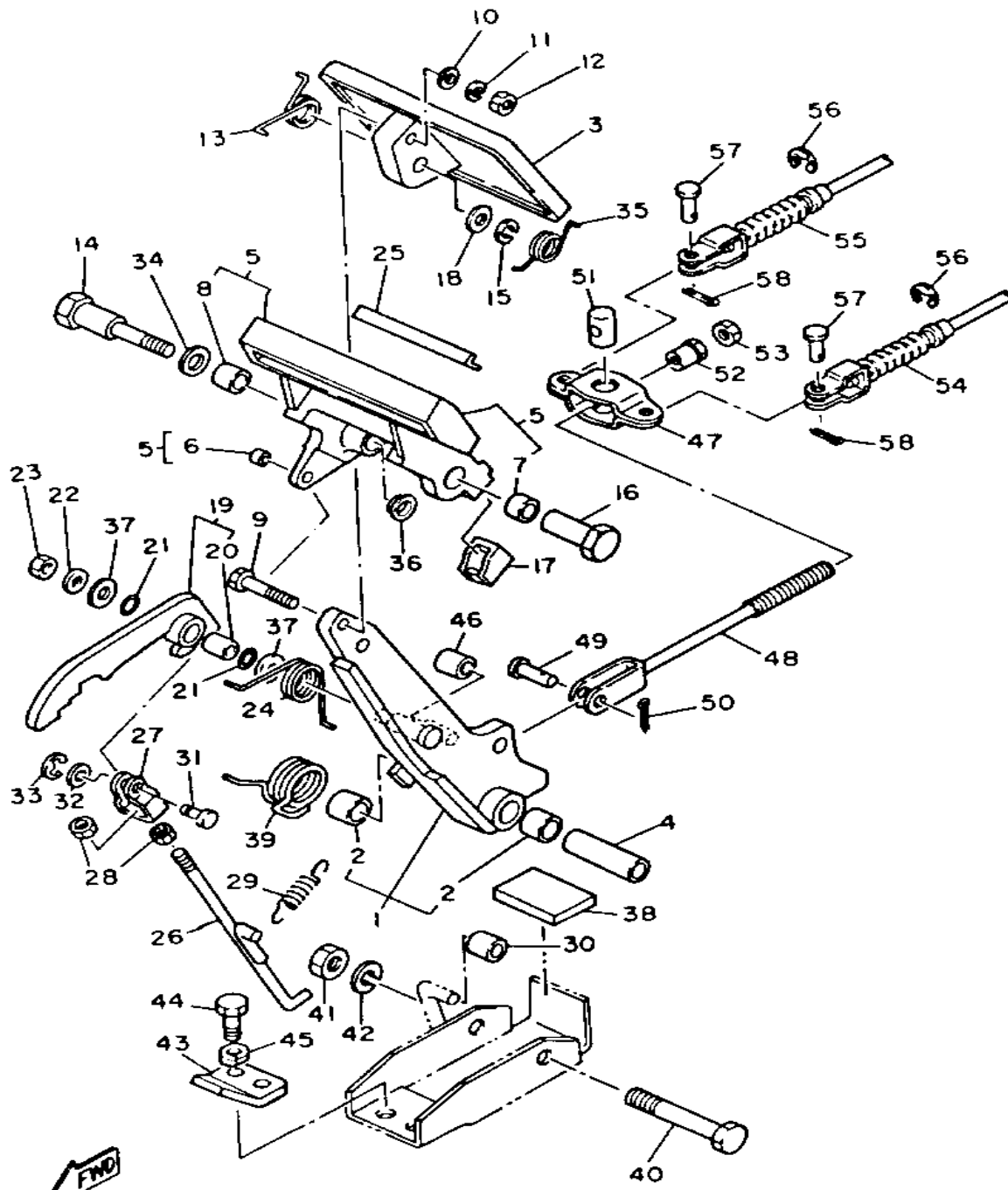

J41110-5050

Ref. No.	Part Number	Description	Qty	Remarks
23	95601-06100-00	NUT, U	1	
24	90508-14548-00	SPRING, TORSION	1	
25	J17-25672-00-00	PAD, PARKING PEDAL	1	
26	J17-27231-00-00	ROD, BRAKE	1	
27	J17-27232-00-00	END, ROD	1	
28	95380-06700-00	NUT	2	
29	90506-12277-00	SPRING, TENSION	1	
30	J17-25672-00-00	PAD, PARKING PEDAL	1	
	J17-25673-00-00	DAMPER, BRAKE	1	
31	J17-27228-00-00	PIN, LINK JOINT	1	
32	92901-05600-00	WASHER, PLATE	1	
33	99080-04600-00	CIRCLIP (E)	1	
34	90201-123F2-00	WASHER, PLAIN	1	
35	90508-26557-00	SPRING, TORSION	1	
36	90380-12105-00	BUSH, SOLID	1	
37	90201-104G8-00	WASHER, PLAIN	2	
38	J17-27245-00-00	PAD, BRAKE PEDAL	1	
39	90508-40543-00	SPRING, TORSION	1	
40	90101-10447-00	BOLT, HEX.	1	
41	95601-10100-00	NUT, U (95602-10100-00)	1	
42	92990-10100-00	WASHER, SPRING	1	
43	J17-27246-00-00	NAIL, BRAKE	1	
44	97313-08020-00	BOLT, HEXAGON	2	
45	92990-08100-00	WASHER	2	
46	J17-25673-00-00	DAMPER, BRAKE	1	
47	J10-25681-00-00	EQUALIZER, BRAKE	1	
48	J20-25685-00-00	ROD	1	
49	91701-10022-00	PIN	1	
50	91490-30020-00	PIN, COTTER	1	

CONTINUED ON NEXT FRAME ►

BRAKE

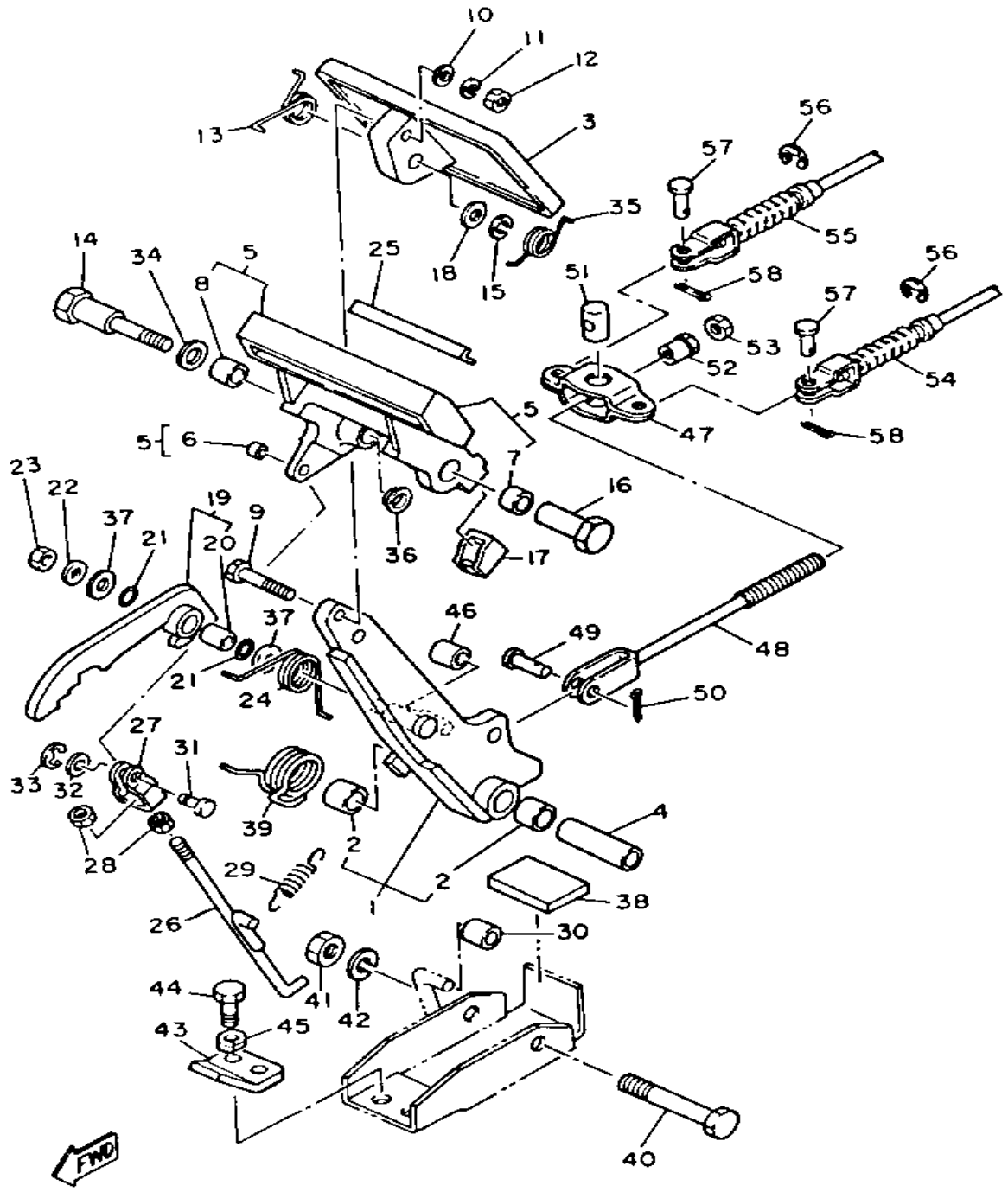

J41110-5050

Ref. No.	Part Number	Description	Qty	Remarks
51	90249-14129-00	PIN	1	
52	90179-08261-00	NUT	1	
53	95303-08700-00	NUT	1	
54	J56-F6341-00-00	CABLE, BRAKE	1	
55	J56-F6351-00-00	CABLE, BRAKE	1	
56	99001-09600-00	CIRCLIP	4	
57	91701-08018-00	PIN	4	
58	91490-25020-00	PIN, COTTER	4	

BRAKE 2

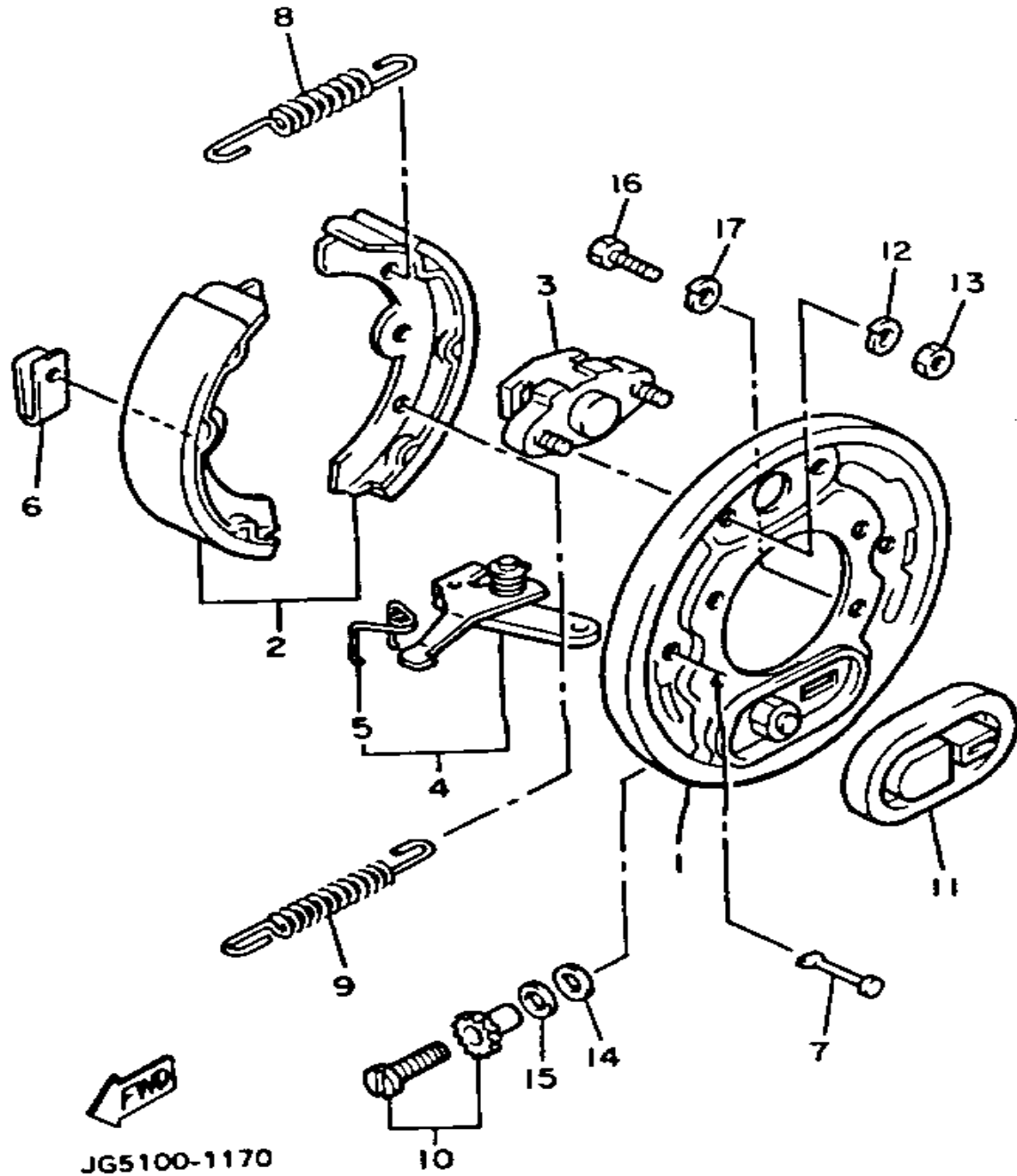

Ref. No.	Part Number	Description	Qty	Remarks
1	J17-27208-00-00	BACKING PLATE SUB ASSEMBLY 1 (R.H)	1	
2	J55-W2536-00-00	BRAKE SHOE SET	1	
3	J17-27206-00-00	ANCHOR BODY COMP.	1	
4	J38-27204-00-00	LEVER ASSEMBLY 1	1	
5	J55-25358-00-00	. SPRING LEVER	1	
6	J10-27281-00-00	SPRING, SHOE CLAMP	2	
7	J10-27282-00-00	PIN, SHOE HOLD DOWN	2	
8	90506-20281-00	SPRING, TENSION	1	
9	90506-26191-00	SPRING, TENSION	1	
10	J55-27270-00-00	ADJUSTER ASSEMBLY	1	
11	J10-27286-00-00	COVER, DUST	1	
12	92995-06100-00	WASHER, SPRING	2	
13	95380-06600-00	NUT	2	
14	90201-121H8-00	WASHER, PLATE	1	
15	90201-121H9-00	WASHER, PLATE	1	
16	97011-08016-00	BOLT	4	
17	92995-06100-00	WASHER, SPRING	4	

BRAKE 3

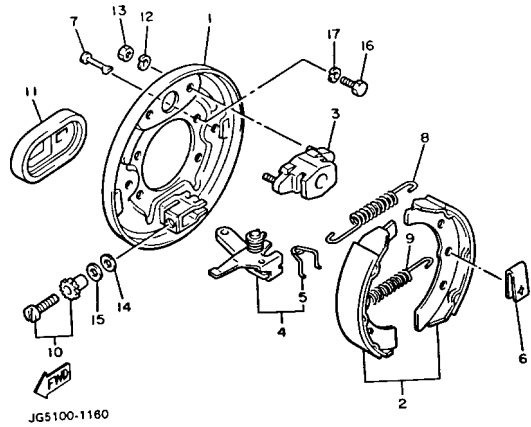

Ref. No.	Part Number	Description	Qty	Remarks
1	J17-27209-00-00	BACKING PLATE SUB ASSEMBLY 2 (L.H)	1	
2	J55-W2536-00-00	BRAKE SHOE SET	1	
3	J17-27206-00-00	ANCHOR BODY COMP.	1	
4	J38-27205-00-00	LEVER ASSEMBLY 2	1	
5	J55-25357-00-00	. SPRING, LEVER	1	
6	J10-27281-00-00	SPRING, SHOE CLAMP	2	
7	J10-27282-00-00	PIN, SHOE HOLD DOWN	2	
8	90506-20281-00	SPRING, TENSION	1	
9	90506-26191-00	SPRING, TENSION	1	
10	J55-27260-00-00	ADJUSTER ASSEMBLY	1	
11	J10-27286-00-00	COVER, DUST	1	
12	92995-06100-00	WASHER, SPRING	2	
13	95380-06600-00	NUT	2	
14	90201-121H8-00	WASHER, PLATE	1	
15	90201-121H9-00	WASHER, PLATE	1	
16	97011-08016-00	BOLT	4	
17	92990-08100-00	WASHER	4	

ACCELERATOR

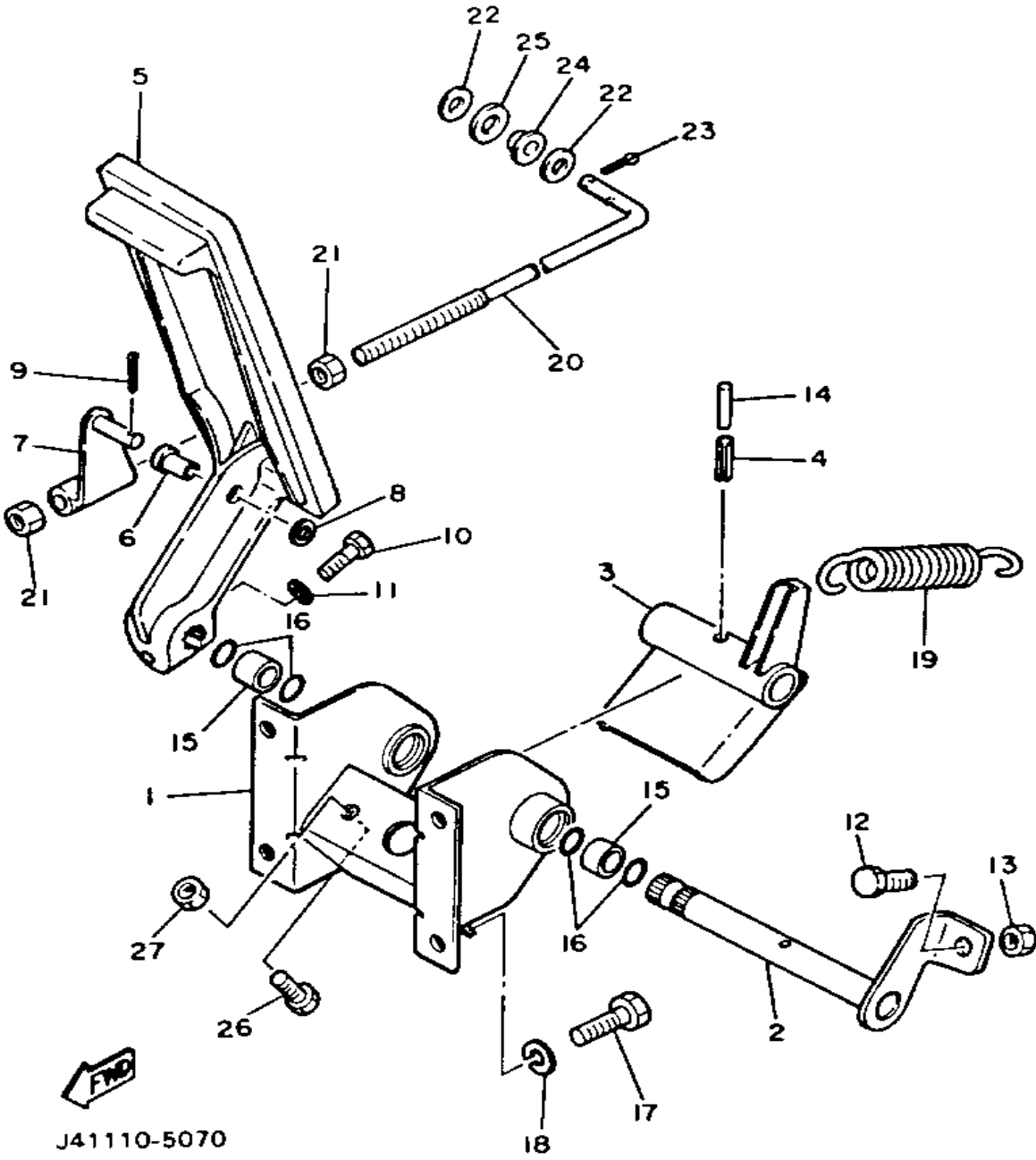

Ref. No.	Part Number	Description	Qty	Remarks
1	J41-27874-00-00	BRACKET, ACCELERATOR		
		PEDAL	1	
2	J17-27853-00-00	SHAFT, PEDAL 1	1	
3	J22-27872-00-00	ARM, ACCELERATOR	1	
4	91609-60025-00	PIN, SPRING	1	
	91609-60028-00	PIN, SPRING	1	
5	JF3-27871-00-00	PEDAL, ACCELERATOR	1	
6	90381-06033-00	BUSH, SOLID	1	
7	J14-27815-00-00	LEVER, CRANK	1	
8	92990-06600-00	WASHER, PLATE	1	
9	91490-20020-00	PIN, COTTER	1	
10	97011-06025-00	BOLT (97001-06025)	1	
11	92995-06100-00	WASHER, SPRING	1	
12	90106-08040-00	BOLT, RD. HEX	1	
13	95303-08700-00	NUT	1	
14	91609-35028-00	PIN, SPRING	1	
15	90384-14080-00	BUSH, BIMETAL	2	
16	93210-14104-00	O-RING	4	
17	97313-06016-00	BOLT, HEXAGON	4	
18	92995-06100-00	WASHER, SPRING	4	
19	90506-29283-00	SPRING, TENSION	1	
20	J14-27241-00-00	ROD, JOINT	1	
21	95303-08700-00	NUT	2	
22	90201-07077-00	WASHER, PLAT	2	
23	91401-25020-00	PIN, COTTER	1	
24	90386-07100-00	BUSH	1	
25	90202-10116-00	WASHER, PLATE	1	
26	97011-06025-00	BOLT (97001-06025)	1	
27	95380-06700-00	NUT	1	

TRANSMISSION 1

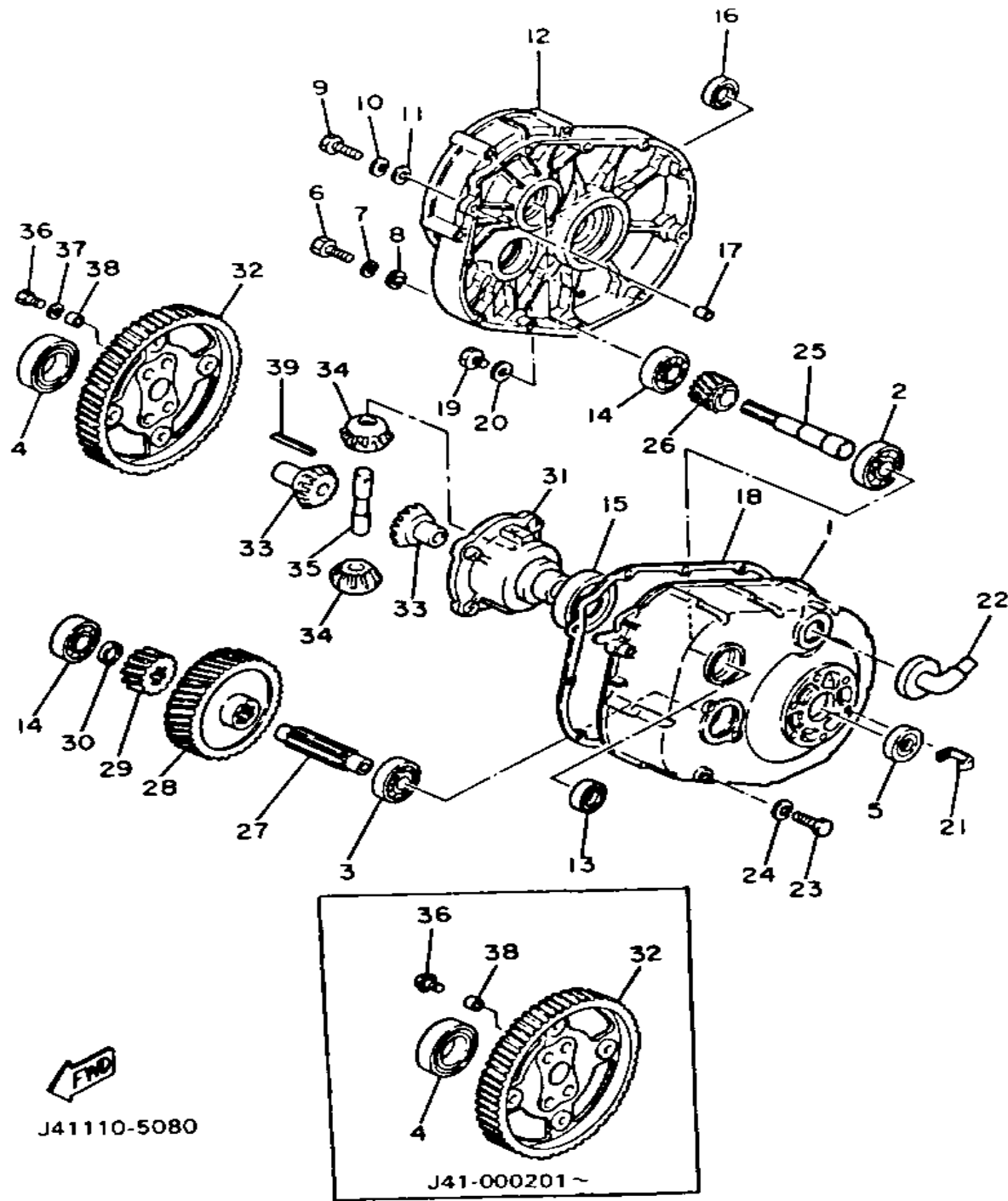

J41110-5080

J41-000201~

Ref. No.	Part Number	Description	Qty	Remarks
1	J14-46311-00-00	CASE, TRANSMISSION 1	1	
2	93306-20529-00	BEARING (B6205C4)	1	
	93306-20541-00	BEARING (B6205)	1	
3	93306-20421-00	BEARING	1	
4	93306-00803-00	BEARING (B6008)	1	
5	93102-22189-00	OIL SEAL	1	
6	97313-08035-00	BOLT, HEXAGON	9	
7	92990-08100-00	WASHER	9	
8	92901-08600-00	WASHER	9	
9	97313-08045-00	BOLT	2	
10	92990-08100-00	WASHER	2	
11	92901-08600-00	WASHER	2	
12	J14-46312-02-00	CASE, TRANSMISSION 2	1	
13	93102-20143-00	OIL SEAL	1	
14	93306-20421-00	BEARING	2	
15	93306-00803-00	BEARING (B6008)	1	
16	93102-22189-00	OIL SEAL	1	
17	99510-12016-00	PIN, DOWEL	2	
18	J10-46319-01-00	GASKET	1	
19	90340-14036-00	PLUG, STRAIGHT SCRW	2	
20	90430-14043-00	GASKET	2	
21	90465-06100-00	CLAMP	1	
22	835-47559-00-00	CAP 2	1	
23	97011-10020-00	BOLT	2	
24	92990-10100-00	WASHER, SPRING	2	
25	J14-46321-01-00	SHAFT, INPUT	1	
26	J10-46331-02-00	GEAR, IMPUT 1	1	
27	J10-46351-00-00	SHAFT, COUNTER	1	
28	J10-46361-02-00	GEAR, COUNTER 1	1	

CONTINUED ON NEXT FRAME ➤

TRANSMISSION 1

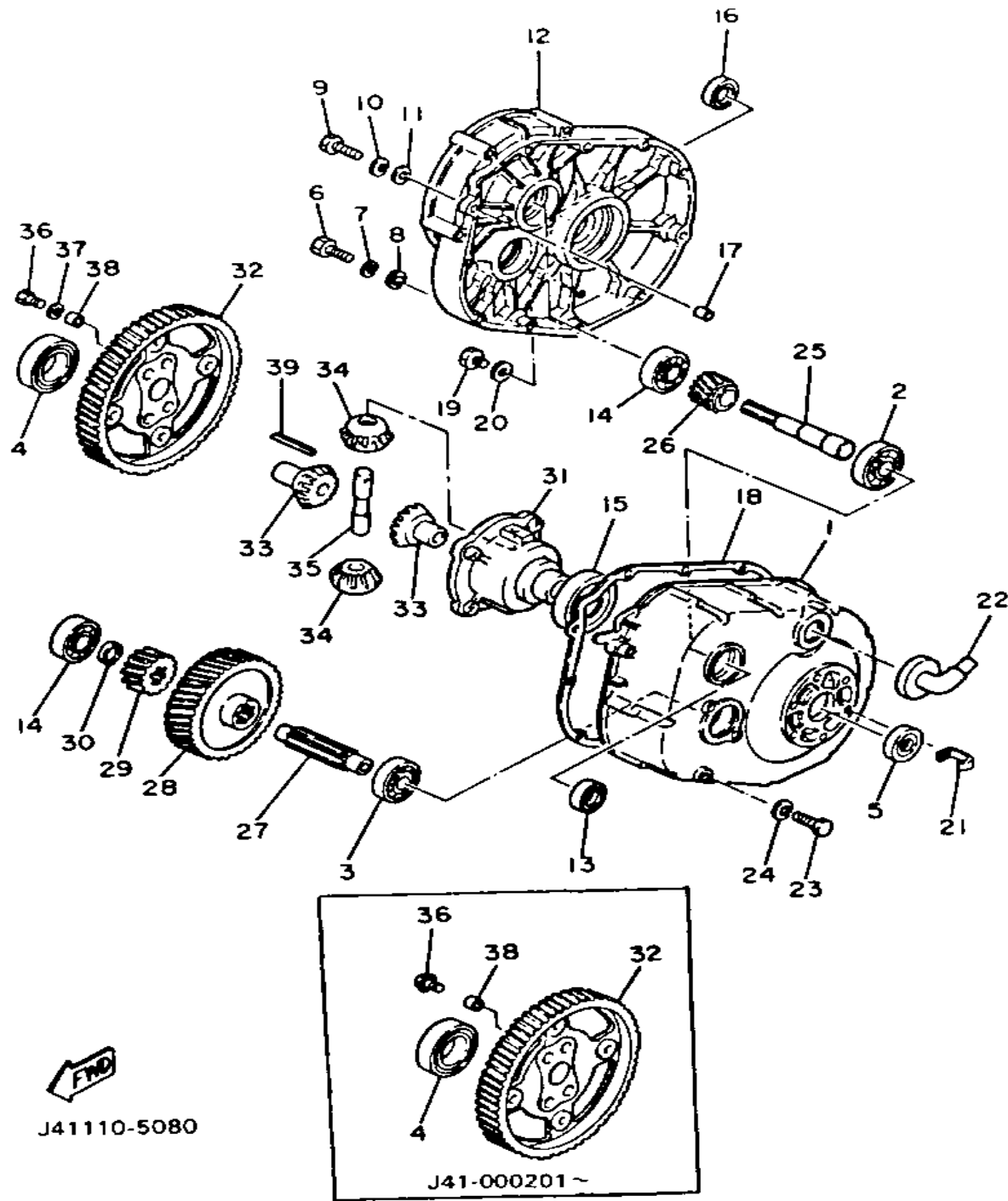

J41110-5080

Ref. No.	Part Number	Description	Qty	Remarks
29	J17-46362-00-00	GEAR, COUNTER 2	1	
30	90201-20272-00	WASHER, PLATE	1	
31	J38-46411-00-00	CASE, differential	1	S/N: J41-000101~ J41-000200
	J38-46411-01-00	CASE, DIFFERENTIAL	1	S/N: J41-000201~
32	J17-46421-00-00	GEAR, ring	1	S/N: J41-000101~ J41-000200
	J41-46421-00-00	GEAR, RING	1	S/N: J41-000201~
33	J38-46414-00-00	GEAR, DIFFERENTIAL SIDE ..	2	
34	J38-46415-00-00	PINION, DIFFERENTIAL	2	
35	J38-46417-02-00	PIN, DIFFERENTIAL	1	
36	90105-08390-00	BOLT, WASHER BASED	4	S/N: J41-000201~
	97313-08030-00	BOLT, HEXAGON	4	S/N: J41-000101~ J41-000200
37	92990-08100-00	WASHER	4	S/N: J41-000101~ J41-000200
38	91812-16001-00	PIN, DOWEL	2	
	99510-10114-00	PIN, DOWEL	2	S/N: J41-000101~ J41-000200
	99510-12016-00	PIN, DOWEL	2	S/N: J41-000201~
39	91609-40036-00	PIN, spring)	1	
	91609-40040-00	PIN, SPRING	1	

REAR AXLE - WHEEL

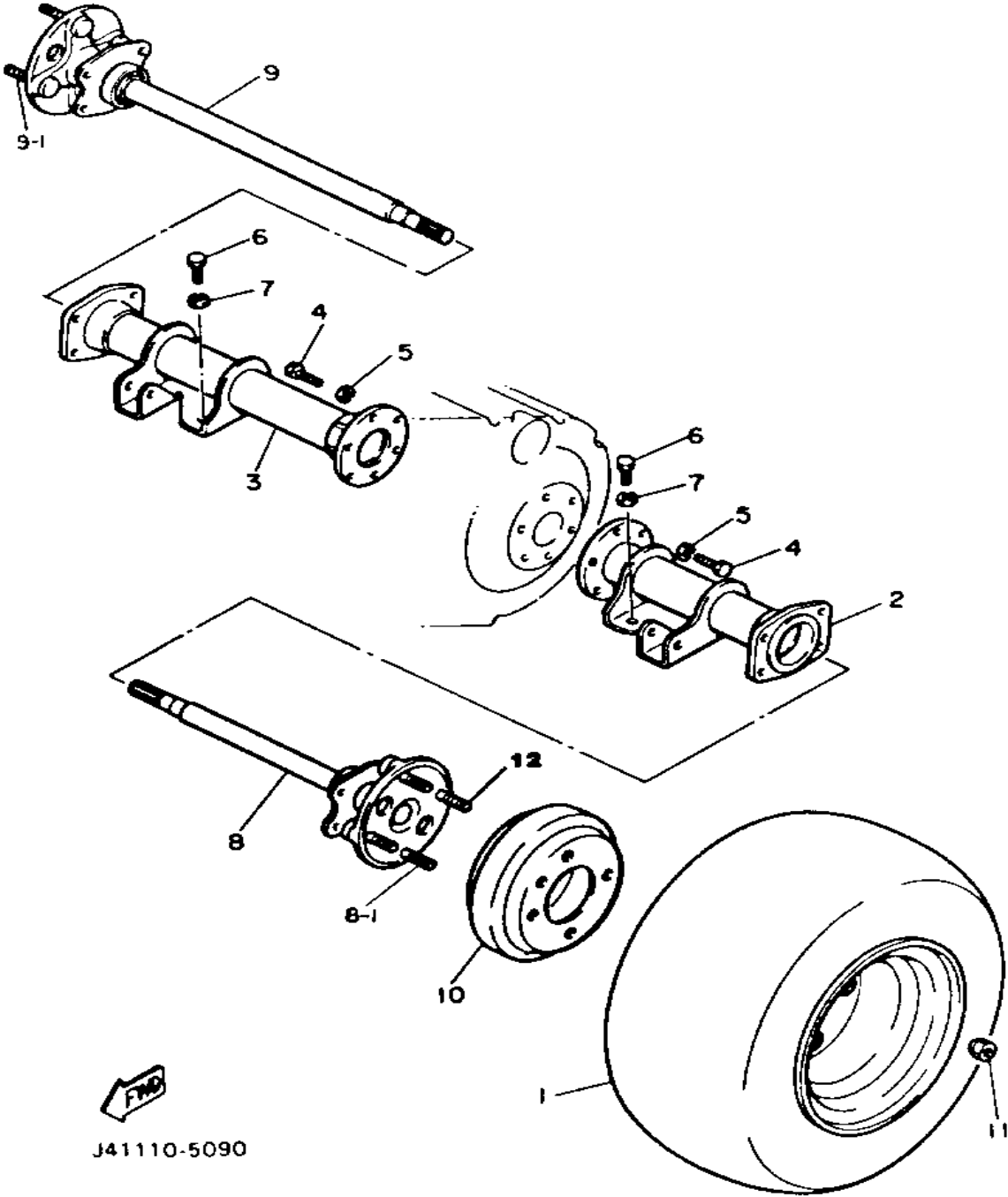

Ref. No.	Part Number	Description	Qty	Remarks
1	J55-F5100-00-00	FRONT WHEEL ASSEMBLY ..	2	LM See Note
2	J41-46540-01-00	REAR AXLE HOUSING COMP.	1	
3	J41-46550-01-00	REAR AXLE HOUSING COMP. 2	1	
4	97013-08025-00	BOLT	12	
5	92990-08100-00	WASHER	12	
6	97011-10020-00	BOLT	8	
7	92990-10100-00	WASHER, SPRING	8	
8	J41-46510-00-00	REAR AXLE SHAFT COMP. ...	1	
9	J41-46520-00-00	REAR AXLE SHAFT COMP. 2 .	1	
10	J55-G6521-00-00	DRUM	2	
11	90179-12262-00	NUT	8	
8-1	90114-12004-00	. BOLT, RIBBED NECK	4	
9-1	90114-12004-00	. BOLT, RIBBED NECK	4	

J41110-5090

BUMPER

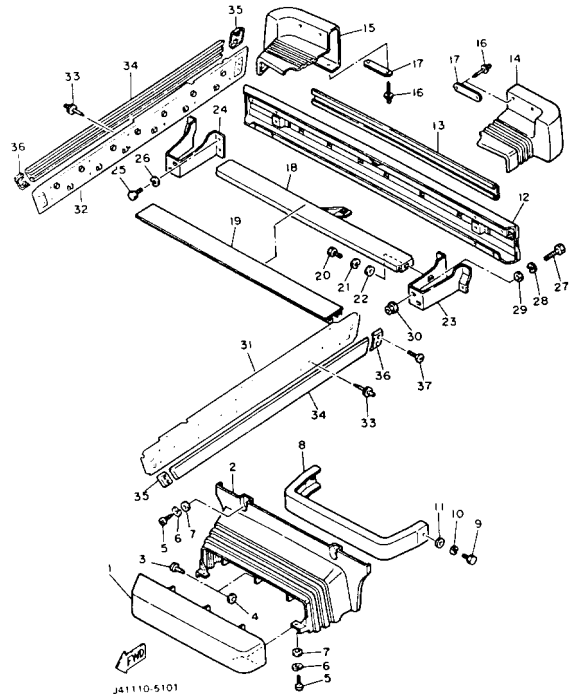

Ref. No.	Part Number	Description	Qty	Remarks
1	J55-K8162-00-00	PAD, FRONT BUMPER	1	
2	J55-K8163-00-00	COVER, BUMPER	1	
3	90269-06028-00	RIVET	3	
4	90201-076J4-00	WASHER, PLATE	3	
5	98506-05020-00	SCREW, PAN HEAD	4	
6	92906-05100-00	WASHER, SPRING	4	
7	90201-05033-00	WASHER, PLATE	4	
8	J55-K7511-00-00	BUMPER, FRONT 1	1	
9	97011-08016-00	BOLT	2	
10	92990-08100-00	WASHER	2	
11	92990-08600-00	WASHER, PLATE	2	
12	JG5-K8107-00-00	BUMPER SUB-ASSEMBLY, REAR	1	
13	J55-K8172-00-00	PAD, REAR BUMPER (J38-78172-00)	1	
14	J55-K8167-00-00	BUMPER, RUBBER 1	1	
15	J55-K8168-00-00	BUMPER, RUBBER 2	1	
16	90267-40077-00	RIVET, BLIND	8	
17	J17-77525-00-00	WASHER 1	4	
18	J38-78179-01-00	PLATE, EXTENSION	1	
19	J55-K8178-00-00	COVER, EXTENSION PLATE (J38-78178-00)	1	
20	97016-08016-00	BOLT	3	
21	92906-08100-00	WASHER, SPRING	3	
22	92906-08600-00	WASHER	3	
23	J55-K8174-00-00	STAY, REAR BUMPER (J38-78174-01)	1	
24	J55-K8175-00-00	STAY, REAR BUMPER 2 (J38-78175-01)	1	
25	97016-08016-00	BOLT	6	

CONTINUED ON NEXT FRAME ►

BUMPER

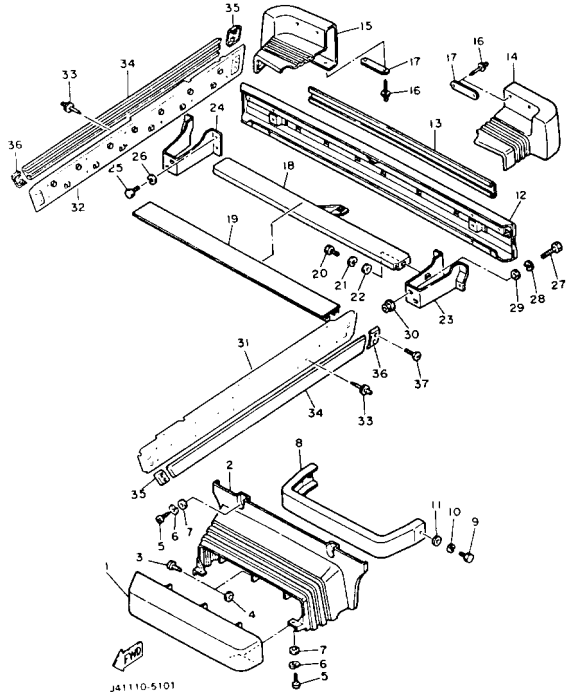

Ref. No.	Part Number	Description	Qty	Remarks
26	92906-08100-00	WASHER, SPRING	6	
27	97026-08050-00	BOLT	4	
28	92906-08100-00	WASHER, SPRING	4	
29	92906-08600-00	WASHER	4	
30	95706-08500-00	NUT, flange	4	
31	J55-WK811-00-00	PLATE, SIDE SILL KIT (L.H) (J55-K8183-00)	1	
32	J55-WK812-00-00	PLATE, SIDE SILL KIT (R.H) (J55-K8184-00)	1	
33	90267-48132-00	RIVET, blind	18	
34	J55-K818A-00-00	PROTECTOR, SIDE PLT	2	
35	J38-7818E-00-00	CAP, PROTECT.END 1	2	
36	J38-7818F-00-00	CAP, PROTECT.END 2	2	
37	98606-06014-00	SCREW, OVAL HEAD (92606-06014)	8	

BODY (G2 - E2)

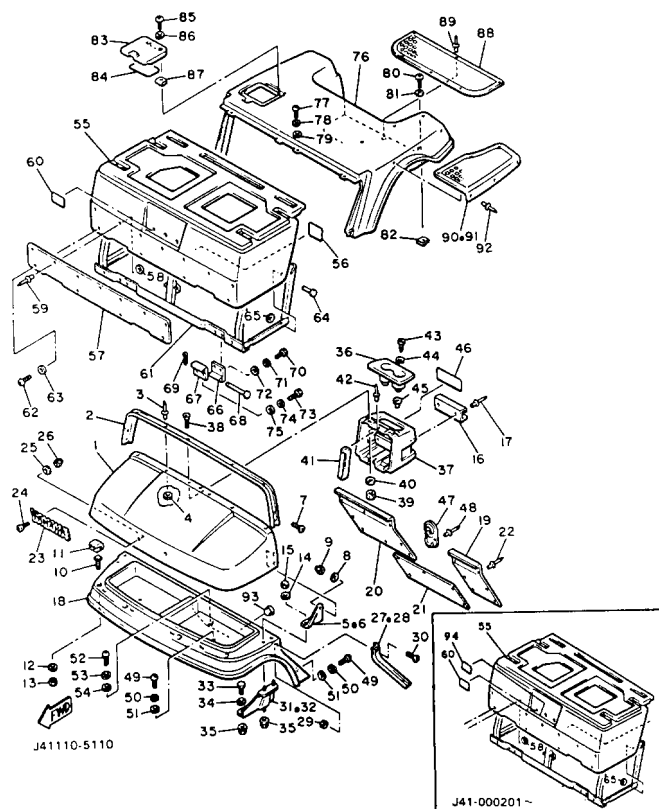

Ref. No.	Part Number	Description	Qty	Remarks
1	J55-K8116-00-00	COWL, FRONT UPPER	1	
2	J38-7811A-01-00	TRIM, UPPER COWL	1	
3	90267-48051-00	RIVET, BLIND	4	
4	90201-046J3-00	WASHER, PLATE	4	
5	J55-K811E-00-00	STAY, UPPER COWL (L.H) (J38-7811E-01)	1	
6	J55-K811F-00-00	STAY, UPPER COWL (R.H) (J38-7811F-01)	1	
7	90151-06039-00	SCREW, COUNTERSUNK	4	
8	92990-06200-00	WASHER	4	
9	95380-06800-00	NUT	4	
10	J38-7811G-00-00	BOLT, COWL FITTING	4	
11	J38-7811H-00-00	RETAINER, COWL FITTING ...	4	
12	90201-065F3-00	WASHER, PLATE	4	
13	95601-06100-00	NUT, U	4	
14	90201-062G3-00	WASHER, PLATE	4	
15	95380-06800-00	NUT	4	
16	J55-K835A-00-00	HOLDER, BALL	1	
17	90267-63047-00	RIVET, BLIND	2	
18	J55-K8115-01-00	COWL, FRONT (J38-78115-02) .	1	
19	J55-K8231-00-00	MAT, MAIN FLOOR 1 (J38-78231-01)	1	
20	J55-K8232-00-00	MAT, MAIN FLOOR 2 (J38-78232-01)	1	
21	J55-K8236-00-00	MAT, PEDAL FLOOR (J38-78236-01)	1	
22	90267-63047-00	RIVET, BLIND	18	
23	J38-24161-00-00	EMBLEM 1	1	
24	90152-04015-00	SCREW, COUNTERSUNK	2	
25	92906-04200-00	WASHER, PLAIN	2	

CONTINUED ON NEXT FRAME ➤

BODY (G2 - E2)

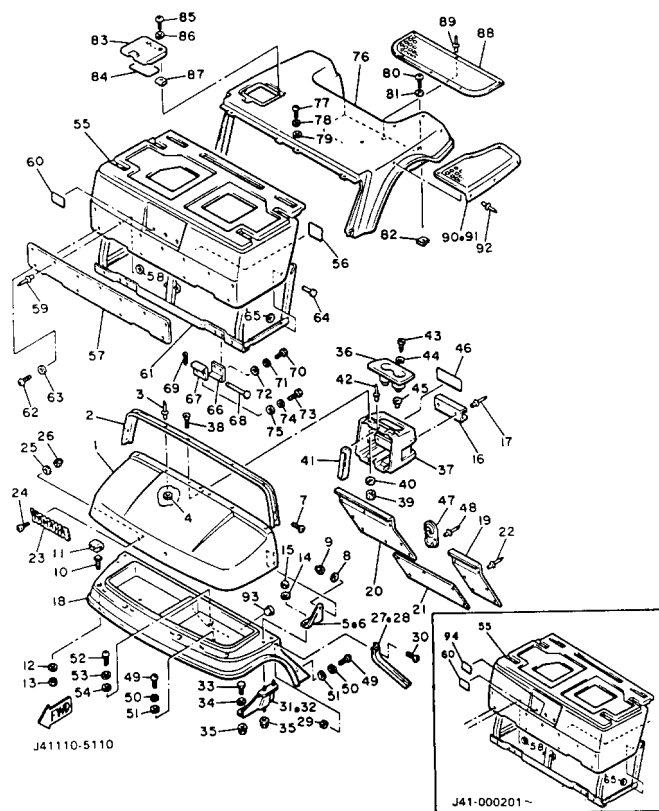

Ref. No.	Part Number	Description	Qty	Remarks
26	95606-04100-00	NUT, U	2	
27	J38-7811L-00-00	TRIM, COWL SIDE (L.H)	1	
28	J38-7811M-00-00	TRIM, COWL SIDE (R.H)	1	
29	J38-7811K-00-00	NUT, TRIM FITTING	4	
30	90151-06039-00	SCREW, COUNTERSUNK	4	
31	J38-7812E-01-00	SUPPORT, UPPER COWL (L.H)	1	
32	J38-7812F-01-00	SUPPORT, UPPER COWL (R.H)	1	
33	97022-08016-00	BOLT	2	
34	92990-08600-00	WASHER, PLATE	2	
35	95701-08500-00	NUT, FLANGE	4	
36	J55-K835E-00-00	HOLDER, BEVERAGE (J38-7835E-03)	1	
37	J55-K835G-00-00	HOUSING, HOLDER (J38-7835G-01)	1	
38	90151-06040-00	SCREW, COUNTERSUNK	2	
39	J38-78145-00-00	NUT, REAR BODY MOUNTING	2	
40	90202-06008-00	WASHER, PLATE	2	
41	J38-7834A-00-00	REINF., HOLDER	1	
42	90267-48086-00	RIVET, BLIND	2	
43	97780-50120-00	SCREW, TAPPING	2	
44	90201-05556-00	WASHER, PLATE	2	
45	90480-07241-00	GROMMET	2	
46	J55-77768-10-00	LABEL, WARNING (J38-77768-10)	1	
47	J38-78273-00-00	COVER, HOLE	1	
48	90269-11042-00	RIVET	2	
49	92580-06020-00	SCREW, PAN HEAD	4	
50	92995-06100-00	WASHER, SPRING	4	
51	90201-06697-00	WASHER, PLATE	4	
52	98580-06016-00	SCREW, PAN HEAD	1	

CONTINUED ON NEXT FRAME ►

BODY (G2 - E2)

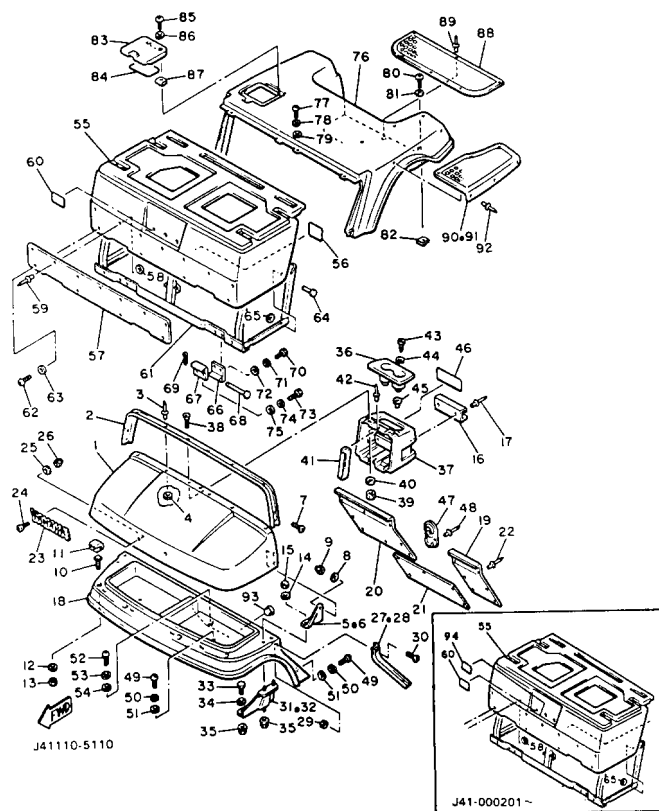

Ref. No.	Part Number	Description	Qty	Remarks
53	92995-06100-00	WASHER, SPRING	1	
54	90201-06049-00	WASHER, PLATE	1	
55	J55-K8141-00-00	PANEL, INTERMEDIATE BODY	1	
56	J22-77765-00-00	LABEL, WARNING 5	1	
57	J38-7814N-00-00	PLATE, ORNAMENT	1	
58	90201-04325-00	WASHER, PLATE	7	
59	90267-40054-00	RIVET, BLIND	7	
60	J41-77458-10-00	LABEL, WARNING (J41-77458-00-00)	1	
61	J56-K8121-00-00	REINFORCEMENT 1 (J41-78121-01)	1	
62	98980-06016-00	SCREW, BINDING	4	
63	90201-06697-00	WASHER, PLATE	4	
64	90338-06169-00	PLUG	2	
65	90183-06011-00	NUT, SPRING	2	
66	J55-K8143-00-00	HINGE, INTERMEDIATE BODY 1	2	
67	J55-K8144-00-00	HINGE, INTERMEDIATE BODY 2	2	
68	91790-06125-00	PIN, CLEVIS	2	
69	91490-20015-00	PIN, COTTER	2	
70	97003-06012-00	BOLT (97001-06012)	4	
71	92995-06100-00	WASHER, SPRING	4	
72	92990-06600-00	WASHER, PLATE	4	
73	97023-06020-00	BOLT (3XF)	4	
74	92995-06100-00	WASHER, SPRING	4	
75	92990-06600-00	WASHER, PLATE	4	
76	90891-60024-00	PANEL, REAR BODY (J38-78142-01)	1	
77	92580-06020-00	SCREW, PAN HEAD	3	

CONTINUED ON NEXT FRAME ►

BODY (G2 - E2)

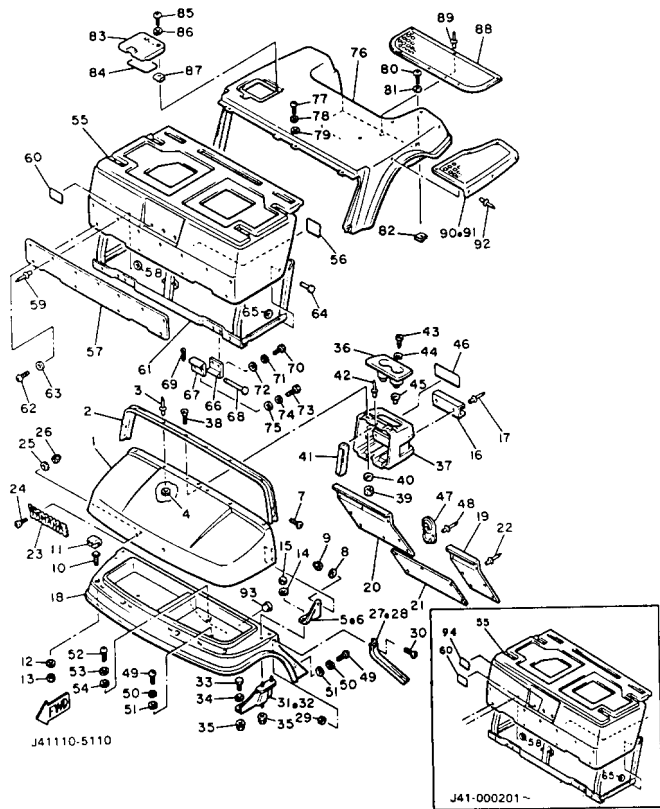

Ref. No.	Part Number	Description	Qty	Remarks
78	92995-06100-00	WASHER, SPRING	3	
79	90201-06M08-00	WASHER, PLATE	3	
80	98980-06016-00	SCREW, BINDING	2	
81	90201-065F3-00	WASHER, PLATE	2	
82	90183-06028-00	NUT, SPRING	2	
83	J55-K8272-00-00	COVER, FUEL INLET	1	
84	J51-77764-00-00	LABEL, WARNING 4	1	
85	98511-04012-00	SCREW, PAN HEAD	2	
86	92901-04600-00	WASHER, PLATE	2	
87	J38-78276-00-00	NUT, INLET FITTING	2	
88	J55-K8241-00-00	MAT, REAR FLOOR (J38-78241-00)	1	
89	90267-63047-00	RIVET, BLIND	6	
90	J55-K8243-00-00	MAT, REAR BODY SIDE (LH) .	1	
91	J55-K8244-00-00	MAT, REAR BODY SIDE (RH) .	1	
92	90267-63047-00	RIVET, BLIND	12	
93	J41-78274-01-00	COVER, HOLE 2	1	
94	J38-77741-10-00	INDICATOR 1	1	S/N: J41-000201~

BODY

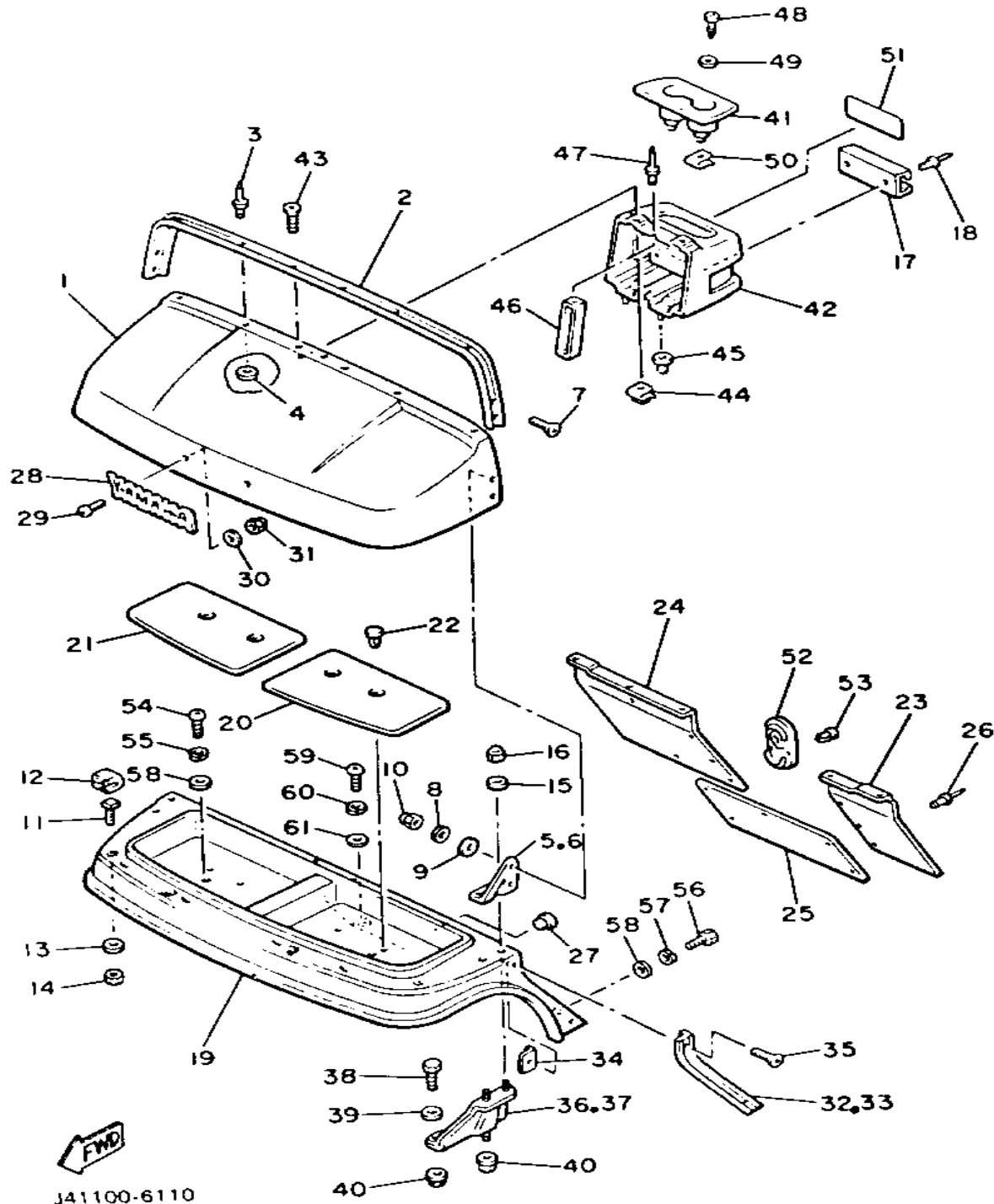

J41100-6110

Ref. No.	Part Number	Description	Qty	Remarks
1	J55-K8116-00-00	COWL, FRONT UPPER	1	
2	J38-7811A-01-00	TRIM, UPPER COWL	1	
3	90267-48051-00	RIVET, BLIND	4	
4	90201-046J3-00	WASHER, PLATE	4	
5	J55-K811E-00-00	STAY, UPPER COWL (L.H) (J38-7811E-01)	1	
6	J55-K811F-00-00	STAY, UPPER COWL (R.H) (J38-7811F-01)	1	
7	90151-06039-00	SCREW, COUNTERSUNK	4	
8	92990-06200-00	WASHER	6	
9	90202-06172-00	WASHER, PLATE	6	
10	95380-06800-00	NUT	4	
11	J38-7811G-00-00	BOLT, COWL FITTING	4	
12	J38-7811H-00-00	RETAINER, COWL FITTING	4	
13	90201-065F3-00	WASHER, PLATE	4	
14	95601-06100-00	NUT, U	4	
15	90201-062G3-00	WASHER, PLATE	2	
16	95380-06800-00	NUT	4	
17	J55-K835A-00-00	HOLDER, BALL	1	
18	90267-63047-00	RIVET, BLIND	2	
19	J55-K8115-01-00	COWL, FRONT (J38-78115-02)	1	
20	ϕJ3-87715-10-00	PAD 1	1	
21	ϕJ3-87715-20-00	PAD 2	1	
22	ϕ90-26908-05-40	RIVET	4	
23	J55-K8231-00-00	MAT, MAIN FLOOR 1 (J38-78231-01)	1	
24	J55-K8232-00-00	MAT, MAIN FLOOR 2 (J38-78232-01)	1	2
25	J55-K8236-00-00	MAT, PEDAL FLOOR (J38-78236-01)	1	

CONTINUED ON NEXT FRAME ►

BODY

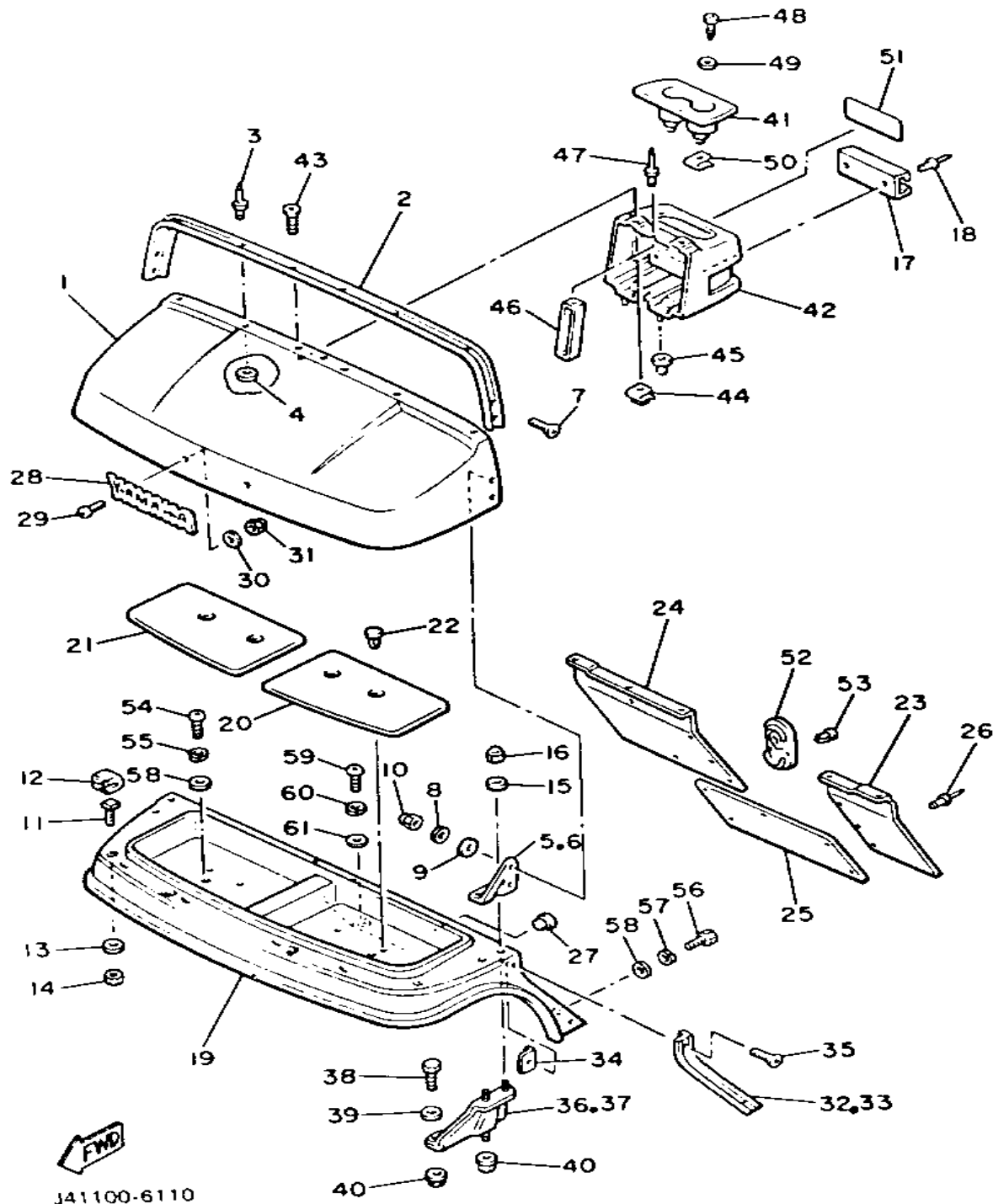

J41100-6110

Ref. No.	Part Number	Description	Qty	Remarks
26	90267-63047-00	RIVET, BLIND	18	
27	J41-78274-01-00	COVER, HOLE 2	1	
28	J38-24161-00-00	EMBLEM 1	1	
29	90152-04015-00	SCREW, COUNTERSUNK	2	
30	92906-04200-00	WASHER, PLAIN	2	
31	95606-04100-00	NUT, U	2	
32	J38-7811L-00-00	TRIM, COWL SIDE (L.H)	1	
33	J38-7811M-00-00	TRIM, COWL SIDE (R.H)	1	
34	J38-7811K-00-00	NUT, TRIM FITTING	4	
35	90151-06039-00	SCREW, COUNTERSUNK	4	
36	J38-7812E-01-00	SUPPORT, UPPER COWL (L.H)	1	
37	J38-7812F-01-00	SUPPORT, UPPER COWL (R.H)	1	
38	97011-08016-00	BOLT	2	
39	92990-08600-00	WASHER, PLATE	2	
40	95701-08500-00	NUT, FLANGE	4	
41	J55-K835E-00-00	HOLDER, BEVERAGE (J38-7835E-03)	1	
42	J55-K835G-00-00	HOUSING, HOLDER (J38-7835G-01)	1	
43	90151-06040-00	SCREW, COUNTERSUNK	2	
44	J38-78145-00-00	NUT, REAR BODY MOUNTING	2	
45	90480-12355-00	GROMMET	2	
46	J38-7834A-00-00	REINF., HOLDER	1	
47	90267-48086-00	RIVET, BLIND	2	
48	97780-50125-00	SCREW, TAPPING	2	
49	90201-05556-00	WASHER, PLATE	2	
50	90183-05001-00	NUT, SPRING	2	
51	J55-77768-10-00	LABEL, WARNING (J38-77768-10)	1	
52	J38-78273-00-00	COVER, HOLE	1	

CONTINUED ON NEXT FRAME ►

BODY

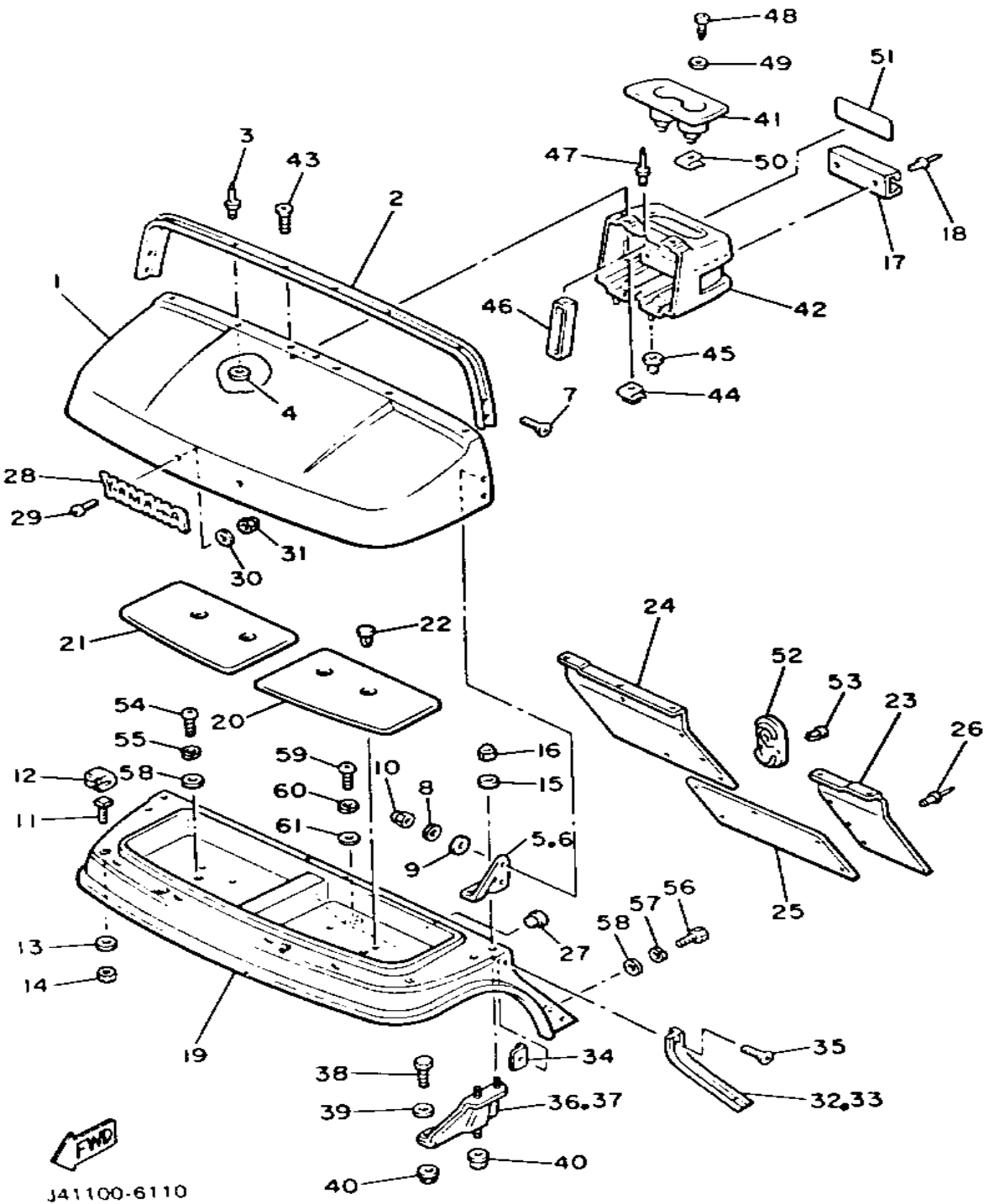

Ref. No.	Part Number	Description	Qty	Remarks
53	90269-11042-00	RIVET	2	
54	92580-06020-00	SCREW, PAN HEAD	2	
55	92990-06100-00	WASHER, SPRING	2	
56	97395-06020-00	BOLT, HEXAGON	2	
57	92995-06100-00	WASHER, SPRING	2	
58	90201-06697-00	WASHER, PLATE	4	
59	92580-06020-00	SCREW, PAN HEAD	1	
60	92995-06100-00	WASHER, SPRING	1	
61	90201-06049-00	WASHER, PLATE	1	

BODY 2 (G2 - E)

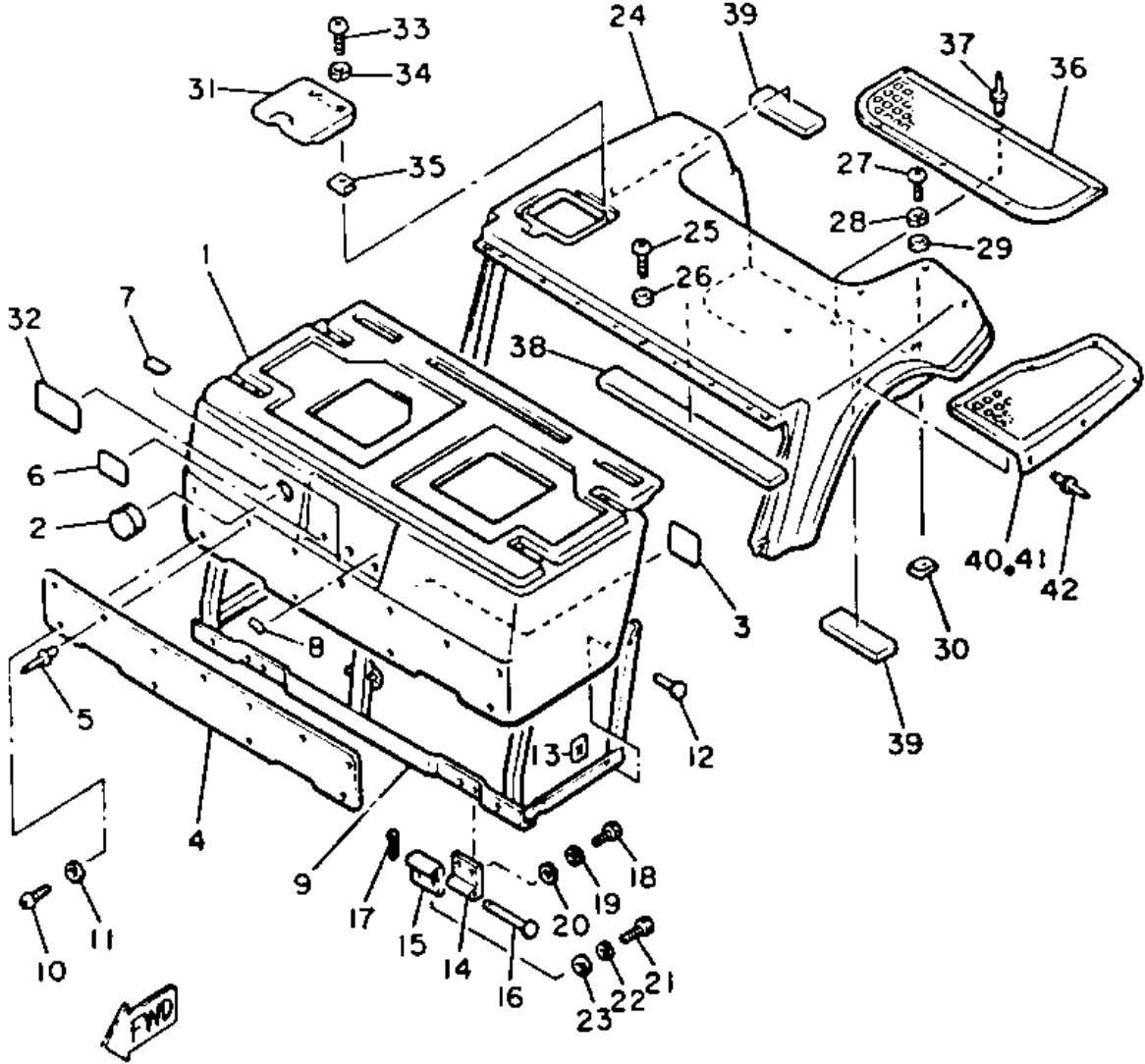

J41100-6120

Ref. No.	Part Number	Description	Qty	Remarks
1	J56-K8141-09-00	PANEL, intermediate body (J41-78141-01)	1	See Note
2	(90480-64442-00)	GROMMET	1	See Note
23	92990-06600-00	WASHER, PLATE	4	

BODY FITTING

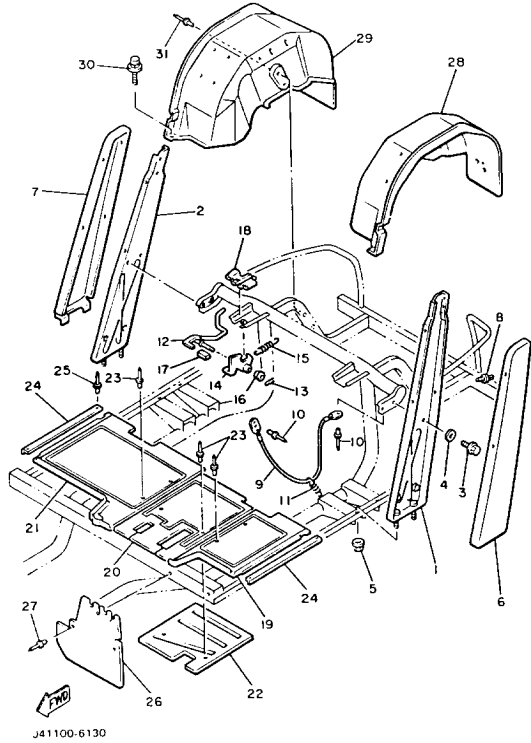

Ref. No.	Part Number	Description	Qty	Remarks
2	J55-K813E-00-00	PILLAR, SIDE R (J38-7813E-01)	1	
3	95811-08016-00	BOLT, FLANGE	4	
4	90201-08730-00	WASHER, PLATE	4	
5	95701-06500-00	NUT, FLANGE	4	
6	J55-K813F-00-00	COVER, SIDE PILLAR (L.H)	1	
7	J55-K813G-00-00	COVER, SIDE PILLAR (R.H)	1	
8	90267-63134-00	RIVET, BLIND	8	
9	J38-78229-00-00	WIRE, SEAT STOPPER	1	
10	90267-40087-00	RIVET, BLIND	2	
11	90507-08037-00	SPRING, TENSION	1	
12	J38-7814G-01-00	LEVER, BODY LOCK	1	
13	90468-18008-00	CLIP	1	
14	J38-7814H-01-00	HOOK, BODY LOCK	1	
15	90506-18374-00	SPRING, TENSION	1	
16	J38-7814L-01-00	BUSH, LEVER END	2	
17	J38-7815H-00-00	DAMPER, LOCK	1	
18	J38-78221-00-00	SHEET, BODY MOUNTING 1	2	
19	J55-K8233-00-00	MAT, MAIN FLOOR 3	1	
20	J55-K8234-00-00	MAT, MAIN FLOOR 4	1	
21	J55-K8235-00-00	SHEET, MAIN FLOOR	1	
22	J55-K8271-00-00	SERVICE LID, PEDAL	1	
23	90267-48101-00	RIVET, BLIND	6	
24	J38-78215-00-00	PLATE, SIDE TRIM	2	
25	90267-40090-00	RIVET, blind	4	
26	J55-K8187-00-00	FLAP, FRONT FENDER (J38-78187-01)	2	
27	90267-48101-00	RIVET, BLIND	4	
28	J56-K8191-00-00	PANEL, REAR FENDER 1 (J41-78191-01)	1	

CONTINUED ON NEXT FRAME ►

BODY FITTING

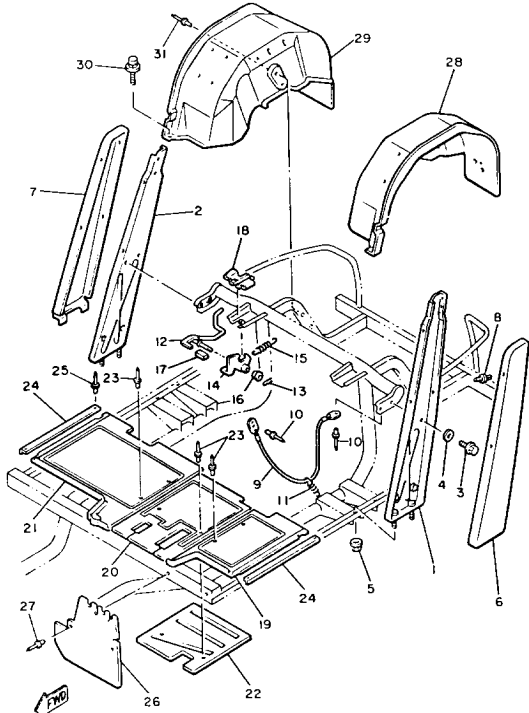

J41100-6130

Ref. No.	Part Number	Description	Qty	Remarks
29	J55-K8192-00-00	PANEL, REAR FENDER 2	1	
30	90119-06108-00	BOLT, WITH WASHER	2	
31	90267-48101-00	RIVET, BLIND	6	

CARRIER

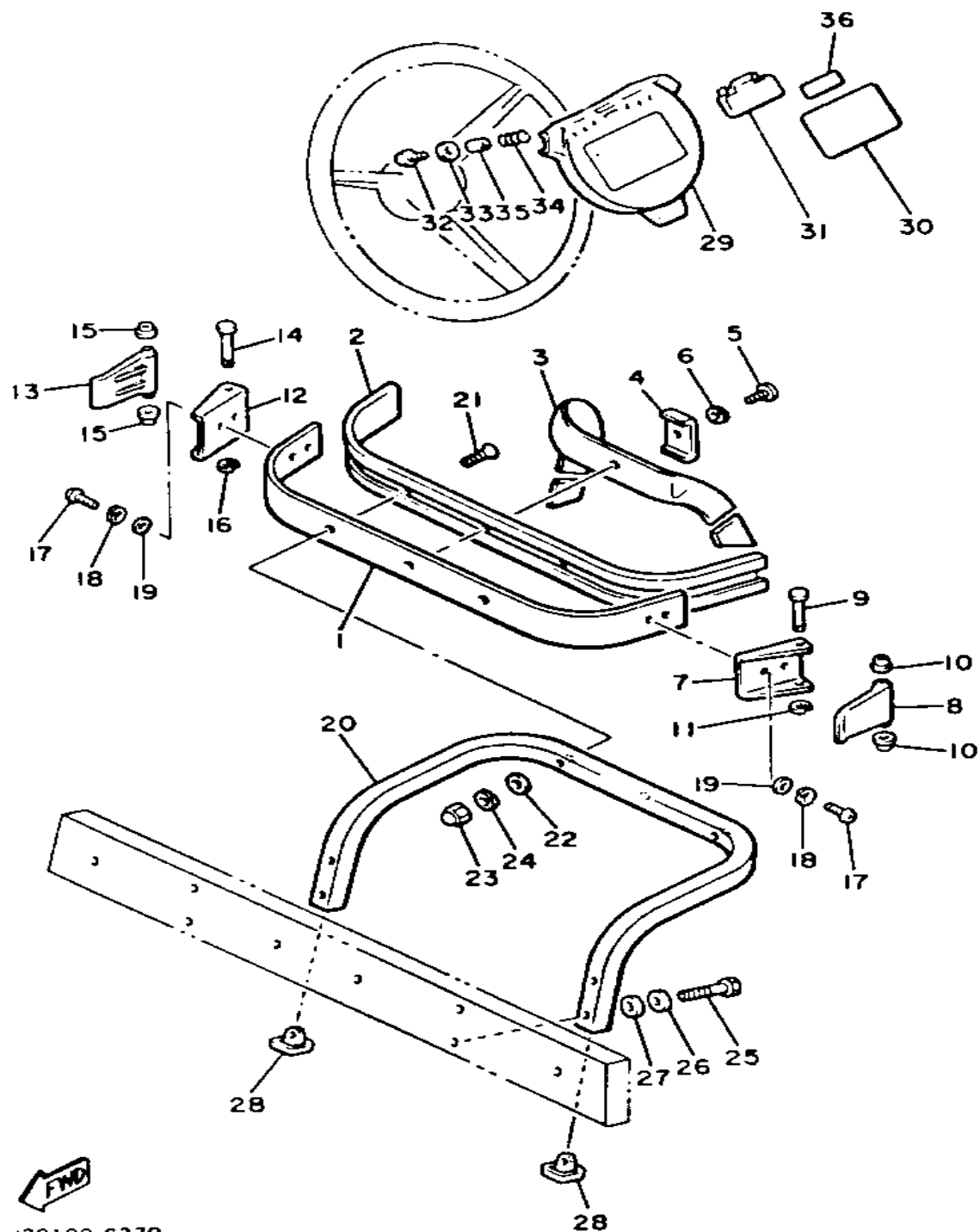

J38100-6270

Ref. No.	Part Number	Description	Qty	Remarks
1	J55-K8351-00-00	SUPPORT, BAG UPPER (J38-78351-00)	1	
2	J38-78356-00-00	PAD, BAG SUPPORT	1	
3	J38-78355-00-00	BAND	1	
4	J38-78367-00-00	PLATE, ANCHOR	1	
5	98980-06016-00	SCREW, BINDING	1	
6	92995-06100-00	WASHER, SPRING	1	
7	J17-78157-01-00	BASE, LOCK	1	
8	J17-78368-01-00	LEVER, LOCK	1	
9	J17-78369-00-00	PIN, LEVER	1	
10	90386-06108-00	BUSH	2	
11	99080-05600-00	CIRCLIP	1	
12	J17-78157-01-00	BASE, LOCK	1	
13	J17-78368-01-00	LEVER, LOCK	1	
14	J17-78369-00-00	PIN, LEVER	1	
15	90386-06108-00	BUSH	2	
16	99080-05600-00	CIRCLIP	1	
17	98580-06010-00	SCREW, PAN HEAD (92503-06010)	4	
18	92995-06100-00	WASHER, SPRING	4	
19	92990-06200-00	WASHER	4	
20	J55-K8352-00-00	SUPPORT, BAG LOWER 1 (J38-78352-01)	1	
21	98701-08040-00	SCREW, FLAT HEAD (92701-08040)	2	
22	90202-08022-00	WASHER, PLATE	2	
23	95380-08800-00	NUT, CROWN	2	
24	92990-08100-00	WASHER	2	
25	90101-08649-00	BOLT	4	
26	90202-08022-00	WASHER, PLATE	4	

CONTINUED ON NEXT FRAME ►

CARRIER

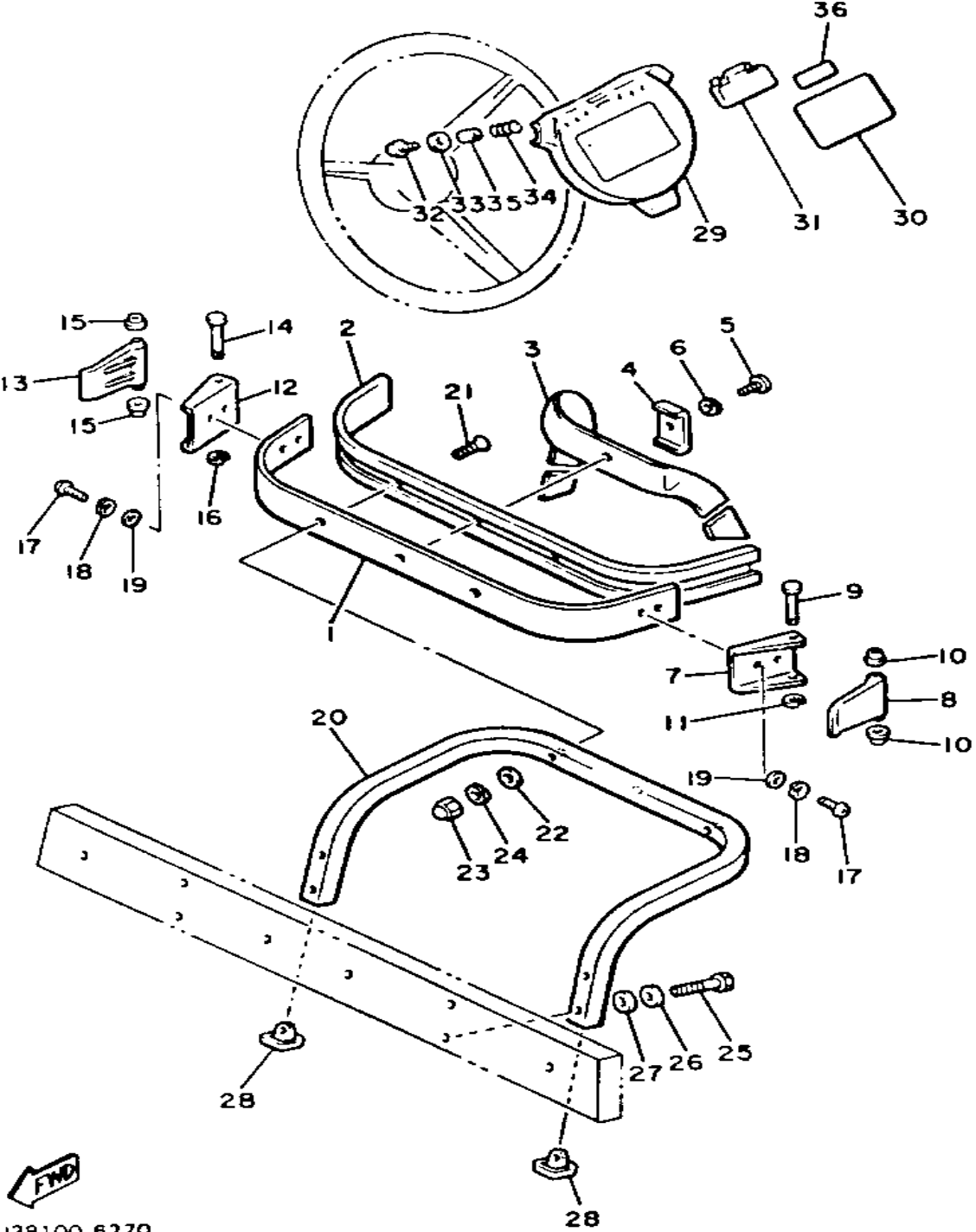

Ref. No.	Part Number	Description	Qty	Remarks
27	90202-08171-00	WASHER, PLATE	6	
28	J38-7835H-00-00	CAP, BAG SUPPORT LOWER .	2	
29	J55-K8357-00-00	HOLDER 1	1	
30	J55-77762-10-00	LABEL, WARNING 2 (J38-77762-01)	1	
31	J55-K8358-00-00	HOLDER 2	1	
32	97706-40525-00	SCREW, TAPPING	2	
33	90201-044H9-00	WASHER, PLAIN	2	
34	90502-10013-00	SPRING, CONICAL	2	
35	90387-046N7-00	COLLAR	2	
36	J51-77763-00-00	LABEL, WARNING 3	1	

FWD
J38100-6270

SEAT

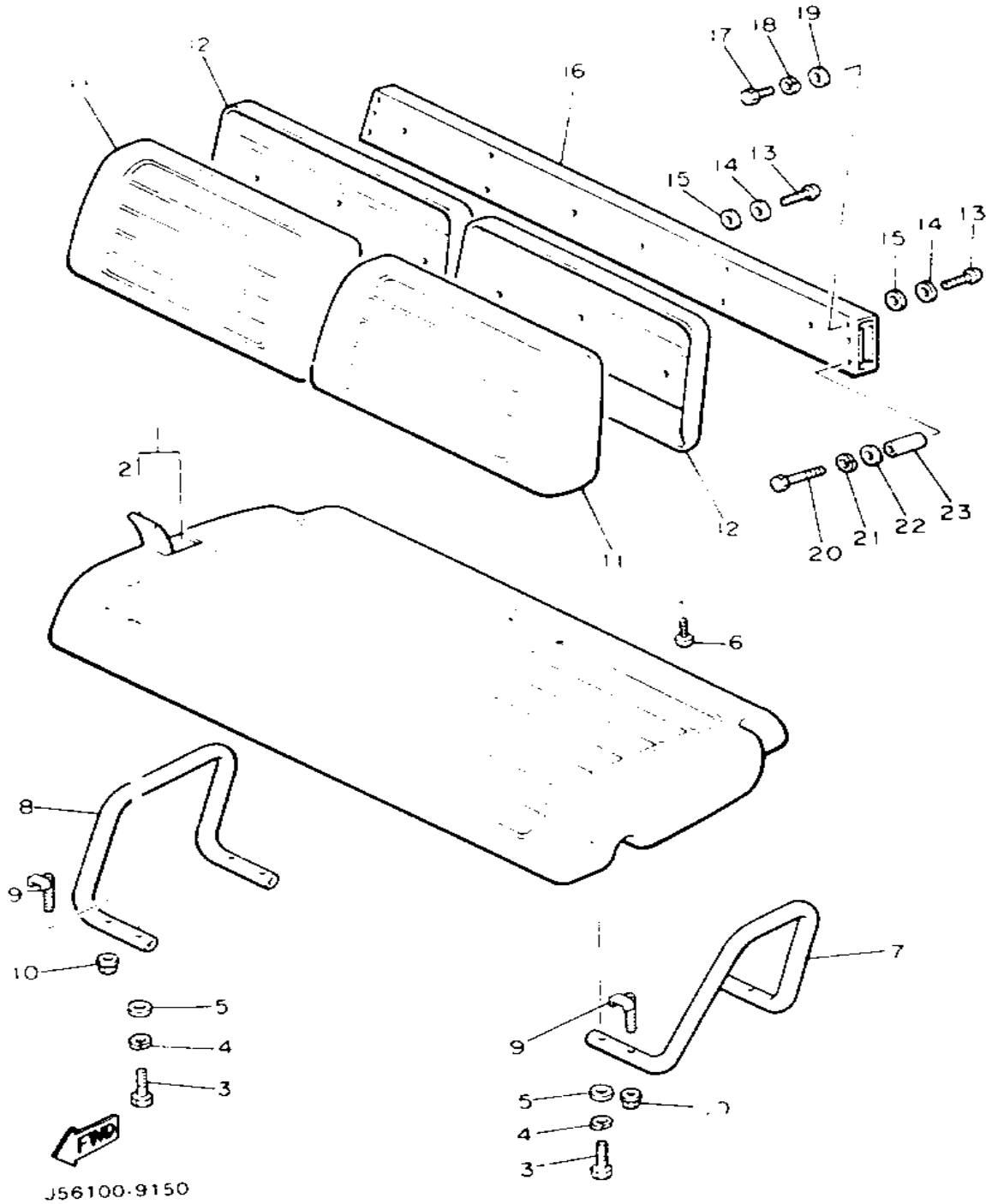

Ref. No.	Part Number	Description	Qty	Remarks
1	J55-K8401-00-00	SEAT SUB ASS'Y CUSHION (J38-78401-02)	1	
2	J55-K8404-09-00	. SEAT COVER	1	
3	97021-08065-00	BOLT	4	
4	92990-08100-00	WASHER	4	
5	92990-08600-00	WASHER, PLATE	4	
6	90149-059U1-00	SCREW, PANHEAD (97701-50516)	1	
7	J38-78361-00-00	ARM REST 1	1	
8	J38-78362-00-00	ARM REST 2	1	
9	J38-78384-00-00	BOLT	4	
10	95601-08200-00	NUT, U	4	
11	J55-K8402-00-00	SEAT SUB ASS'Y, BACK (J38-78402-01)	2	
12	J55-K8413-00-00	COVER, SEAT BACK	2	
13	98980-06045-00	SCREW, BIND	4	
14	90201-065F3-00	WASHER, PLATE	4	
15	90202-06170-00	WASHER, PLATE	4	
16	J55-K8423-09-00	SUPPORT, SEAT BACK (J55-K8423-00)	1	
17	97022-08016-00	BOLT	2	
18	92990-08100-00	WASHER	2	
19	92990-08600-00	WASHER, PLATE	2	
20	97022-08075-00	BOLT	2	
21	92990-08100-00	WASHER	2	
22	92990-08600-00	WASHER, PLATE	2	
23	90387-103G9-00	COLLAR	2	
11-1	J55-K841G-00-00	. COVER, seat back 2	2	

STARTING MOTOR

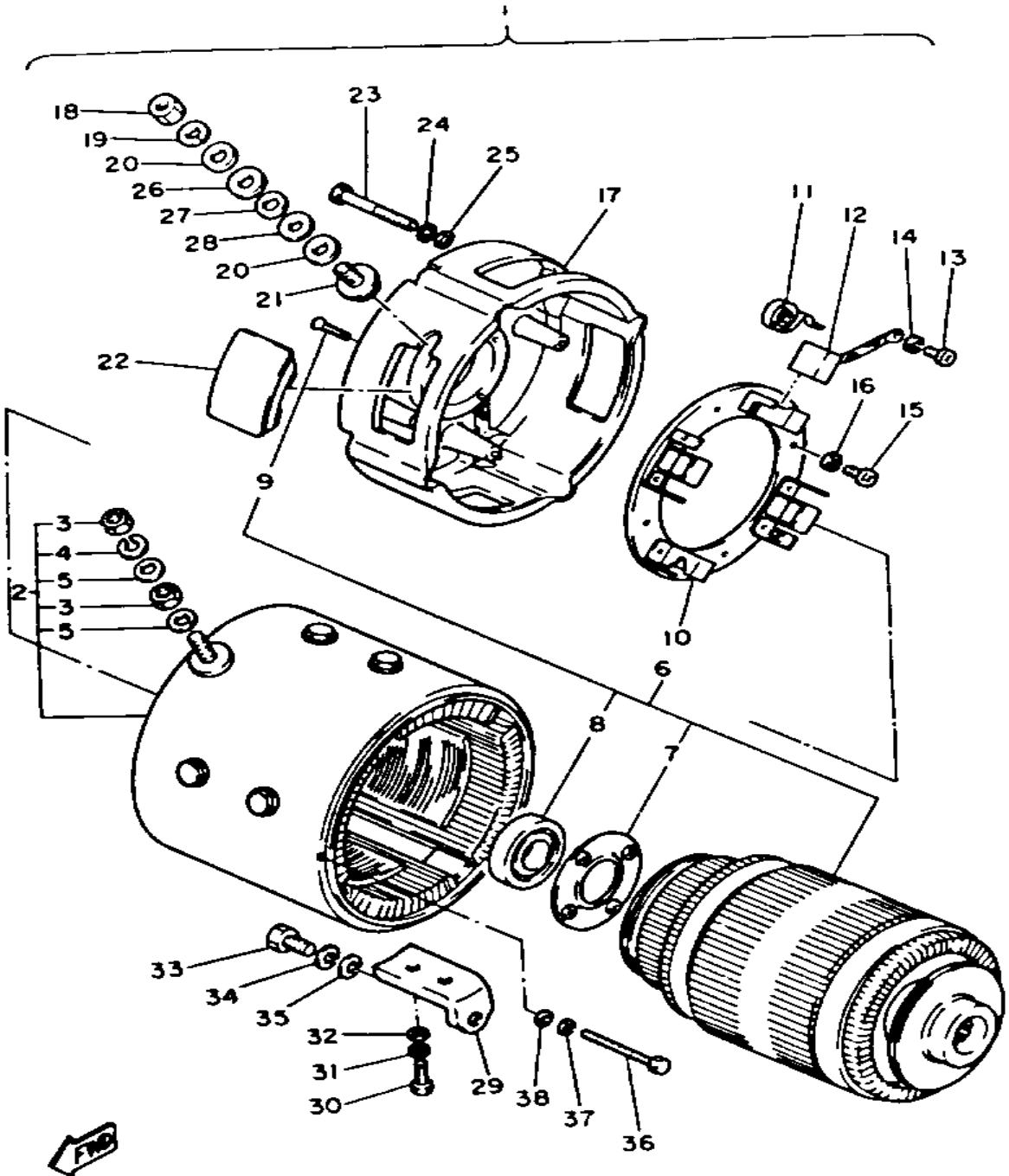

J36100-4150

Ref. No.	Part Number	Description	Qty	Remarks
1	JG6-H1890-01-00	MOTOR ASSEMBLY (JG6-H1890-00-00)	1	
2	J14-81810-10-00	. STATOR ASS'Y	1	
3	95303-08600-00	. . NUT	4	
4	92990-08100-00	. . WASHER	2	
5	92990-08200-00	. . WASHER, PLAIN	4	
6	J14-81850-10-00	. ARMATURE ASS'Y	1	
7	J14-81856-10-00	. . RETAINER	1	
8	J14-81857-10-00	. . BEARING	1	
9	98701-05020-00	. . SCREW, FLAT HEAD	4	
10	J14-81840-10-00	. BRUSH HOLDER ASS'Y	1	
11	J14-81813-10-00	. SPRING, BRUSH	4	
12	J14-81811-10-00	. BRUSH 1	4	
13	98501-05010-00	. SCREW, PAN HEAD	4	
14	92990-05100-00	. WASHER, SPRING	4	
15	98580-05016-00	. SCREW, PAN HEAD	4	
16	92990-05100-00	. WASHER, SPRING	4	
17	J14-81822-10-00	. BRACKET, STARTING MOTOR	1	
18	95303-08600-00	. NUT	2	
19	92990-08100-00	. WASHER	2	
20	92990-08200-00	. WASHER, PLAIN	2	
21	J14-81826-10-00	. BOLT	2	
22	J14-81842-10-00	. COVER	4	
23	J14-81828-10-00	. BOLT 2	4	
24	92990-06600-00	. WASHER, PLATE	4	
25	92990-06600-00	. WASHER, PLATE	4	
26	J14-81843-00-00	. WASHER 1	2	
27	J14-81845-00-00	. PLATE	2	
28	J14-81824-00-00	. WASHER 2	2	

CONTINUED ON NEXT FRAME ►

STARTING MOTOR

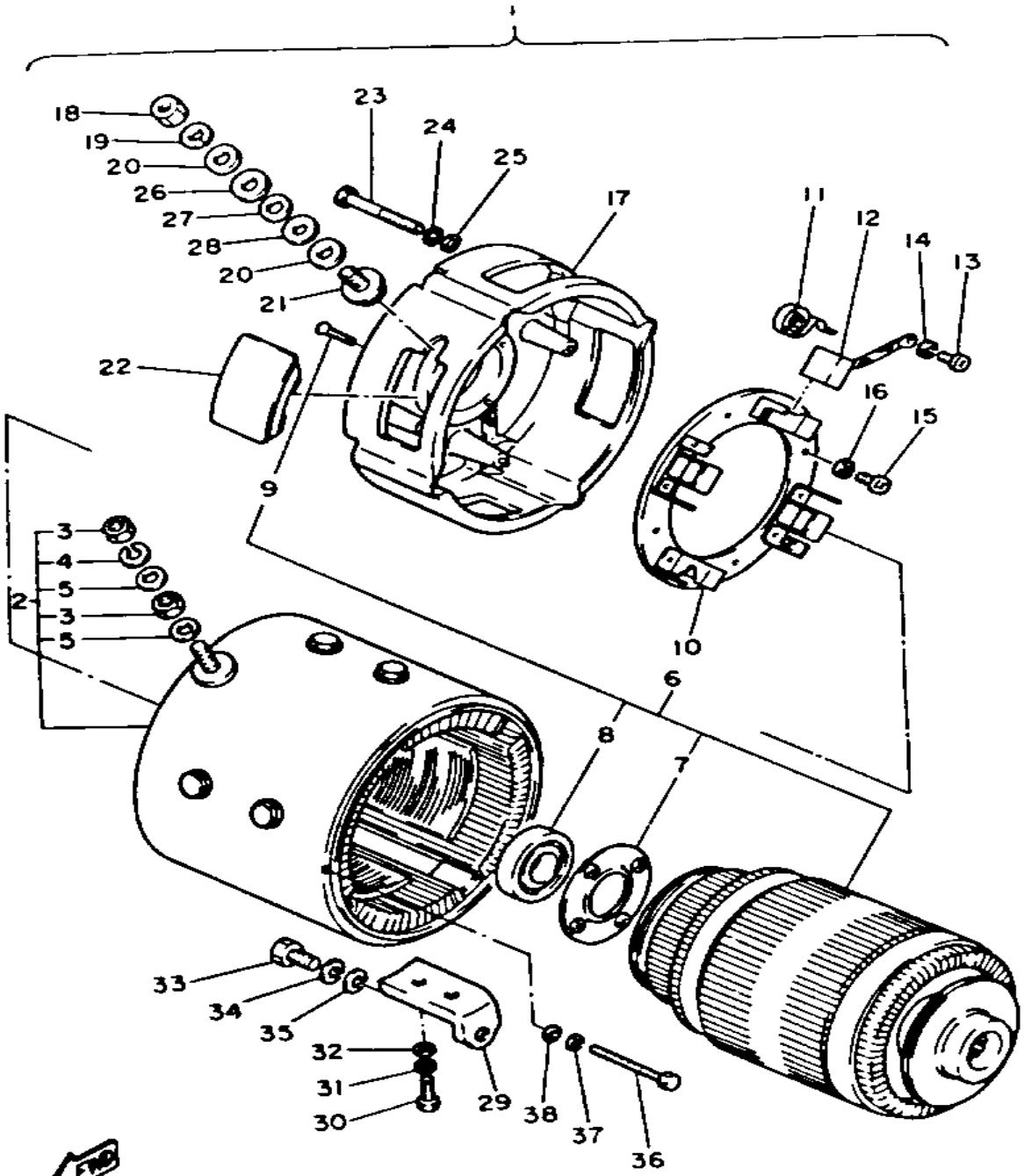

J36100-4150

Ref. No.	Part Number	Description	Qty	Remarks
29	J14-81823-01-00	STAY, STARTING MTR (J14-81823-00)	1	
30	97011-06016-00	BOLT	2	
31	92995-06100-00	WASHER, SPRING	2	
32	92990-06600-00	WASHER, PLATE	2	
33	97022-08016-00	BOLT	1	
34	92990-08100-00	WASHER	1	
35	92990-08600-00	WASHER, PLATE	1	
36	97313-06055-00	BOLT, HEXAGON (97322-06055)	3	
37	92995-06100-00	WASHER, SPRING	3	
38	90201-06643-00	WASHER, PLATE	3	

CONTROLLER 1

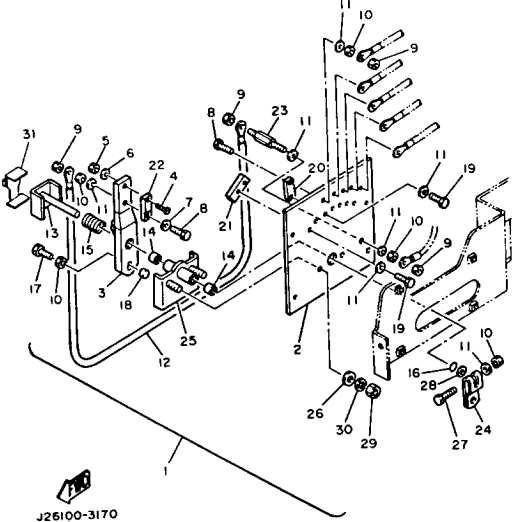

Ref. No.	Part Number	Description	Qty	Remarks
1	J46-86140-00-00	CONTROLLER ASS'Y (J22-86140-00)	1	
2	J46-86142-00-00	. BASE, PLATE	1	
3	J22-86152-00-00	. ARM, MOVING	1	
4	98701-04016-00	. SCREW, FLAT HEAD (98702-04016)	1	
5	95301-04600-00	. NUT	1	
6	92902-04300-00	. WASHER, IN.TOOTH	1	
7	90201-063F3-00	. WASHER, PLATE	1	
8	90101-06469-00	. BOLT	7	
9	95320-06600-00	. NUT	8	
10	95380-06700-00	. NUT	9	
11	92995-06100-00	. WASHER, SPRING	16	
12	J22-86157-00-00	. WIRE, LEAD	1	
13	J14-86155-01-00	. SHAFT, CONTROLLER	1	
14	90380-10010-00	. BUSH, SOLID	2	
15	90501-16573-00	. SPRING, COMPRESSION	1	
16	93210-10166-00	. O-RING	1	
17	97023-06020-00	. BOLT (3XF)	1	
18	90386-05111-00	. BUSH, SPEC'L NYLON	1	
19	97013-06012-00	. BOLT	7	
20	J14-86162-00-00	. CONTACT, STATE	5	
21	J14-82103-00-00	. TERMINAL 1	1	
22	J14-86153-00-00	. CONTACT, MOVING	1	
23	J22-82104-00-00	. TERMINAL 2	1	
24	J14-86144-01-00	. LEVER, CONTROLLER	1	
25	J14-86156-00-00	. HOLDER, SHAFT	1	
26	92990-06600-00	. WASHER, PLATE	2	
27	97021-06030-00	. BOLT	1	

CONTINUED ON NEXT FRAME ➤

CONTROLLER 1

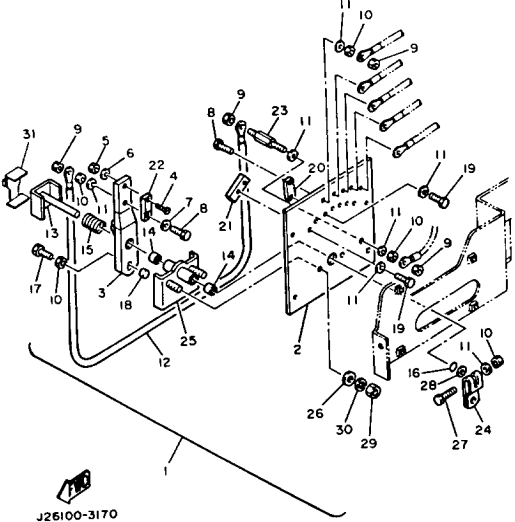

Ref. No.	Part Number	Description	Qty	Remarks
28	92990-10200-00	. WASHER, PLAIN	1	
29	95303-08600-00	. NUT	2	
30	92990-08100-00	. WASHER	2	
31	J22-86158-00-00	. SPRING, COMPRESSION	1	

CONTROLLER 2

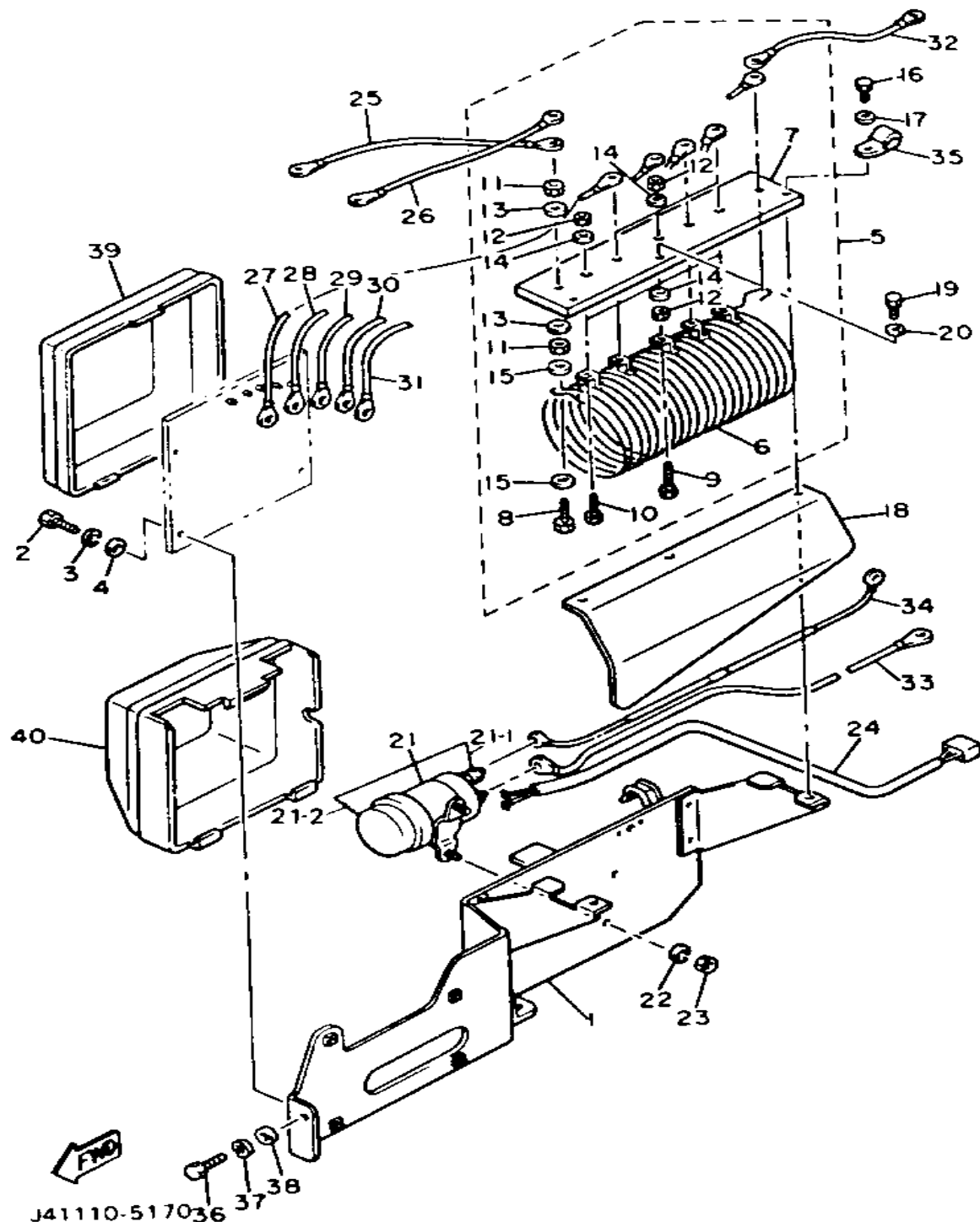

Ref. No.	Part Number	Description	Qty	Remarks
1	J41-86141-00-00	PLATE, CONTROLLER	1	
2	97313-06016-00	BOLT, HEXAGON	4	
3	92995-06100-00	WASHER, SPRING	4	
4	92990-06600-00	WASHER, PLATE	4	
5	J51-85370-00-00	RESISTOR ASSEMBLY	1	
6	J51-85370-00-00	. RESISTOR ASSEMBLY	1	
7	J14-85378-01-00	. PLATE, RESISTOR	1	
8	90101-08470-00	. BOLT	2	
9	90101-06469-00	. BOLT	4	
10	97011-06025-00	. BOLT (97001-06025)	1	
11	95303-08700-00	. NUT	4	
12	95380-06700-00	. NUT	10	
13	92990-08600-00	. WASHER, PLATE	4	
14	92990-06600-00	. WASHER, PLATE	10	
15	90201-083F1-00	. WASHER, PLATE	4	
16	97313-06016-00	BOLT, HEXAGON	2	
17	92990-06600-00	WASHER, PLATE	2	
18	J14-85379-00-00	COVER, RESISTOR	1	
19	97313-06016-00	BOLT, HEXAGON	1	
20	92990-06600-00	WASHER, PLATE	1	
21	J41-81950-00-00	RELAY ASSEMBLY.	1	
22	92990-08100-00	WASHER	2	
23	95303-08700-00	NUT	2	
24	J41-86177-00-00	WIRE, LEAD 7	1	
25	J41-86176-00-00	WIRE, LEAD	1	
26	J14-86175-00-00	WIRE, LEAD 5	1	
27	J14-86175-00-00	WIRE, LEAD 5	1	
28	J14-86175-00-00	WIRE, LEAD 5	1	
29	J14-86175-00-00	WIRE, LEAD 5	1	

CONTINUED ON NEXT FRAME ►

CONTROLLER 2

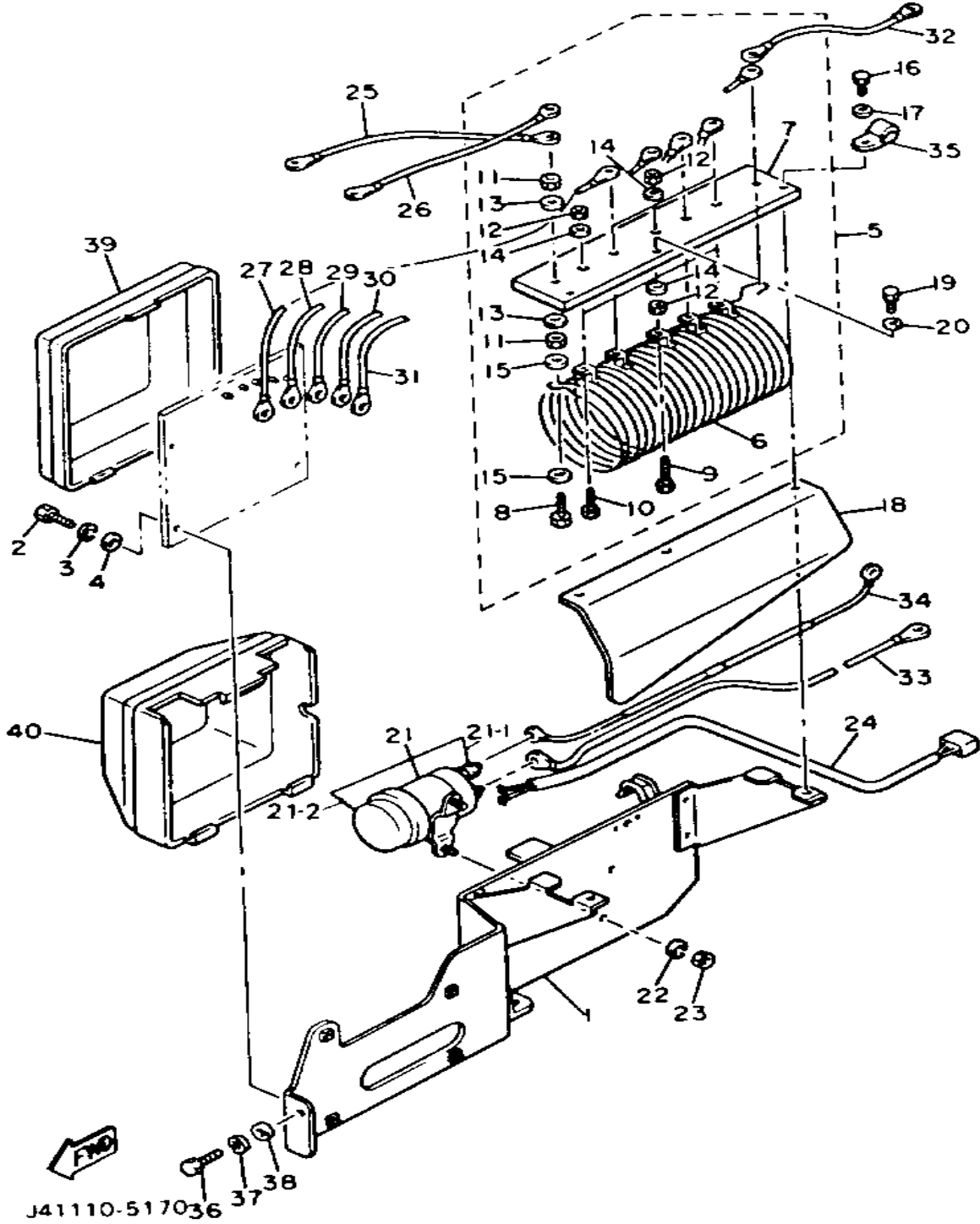

Ref. No.	Part Number	Description	Qty	Remarks
30	J14-86175-00-00	WIRE, LEAD 5	1	
31	J14-86175-00-00	WIRE, LEAD 5	1	
32	J56-H2117-00-00	WIRE, LEAD	1	
33	J41-82117-01-00	WIRE, LEAD (J41-82117-00)	1	
34	J14-82531-00-00	WIRE, LEAD	1	
35	90465-08028-00	CLAMP	1	
36	97022-08016-00	BOLT	2	
37	92990-08100-00	WASHER	2	
38	92990-08600-00	WASHER, PLATE	2	
39	J56-H6163-00-00	. COVER, CONTROLLER	1	
40	J56-H1942-00-00	COVER (J22-81942-00)	1	
21-1	J41-81920-09-00	. G2A/E SLND RBLDKIT	1	
21-2	J38-8195R-00-00	. RUBBER BOOT	1	

ELECTRICAL 1

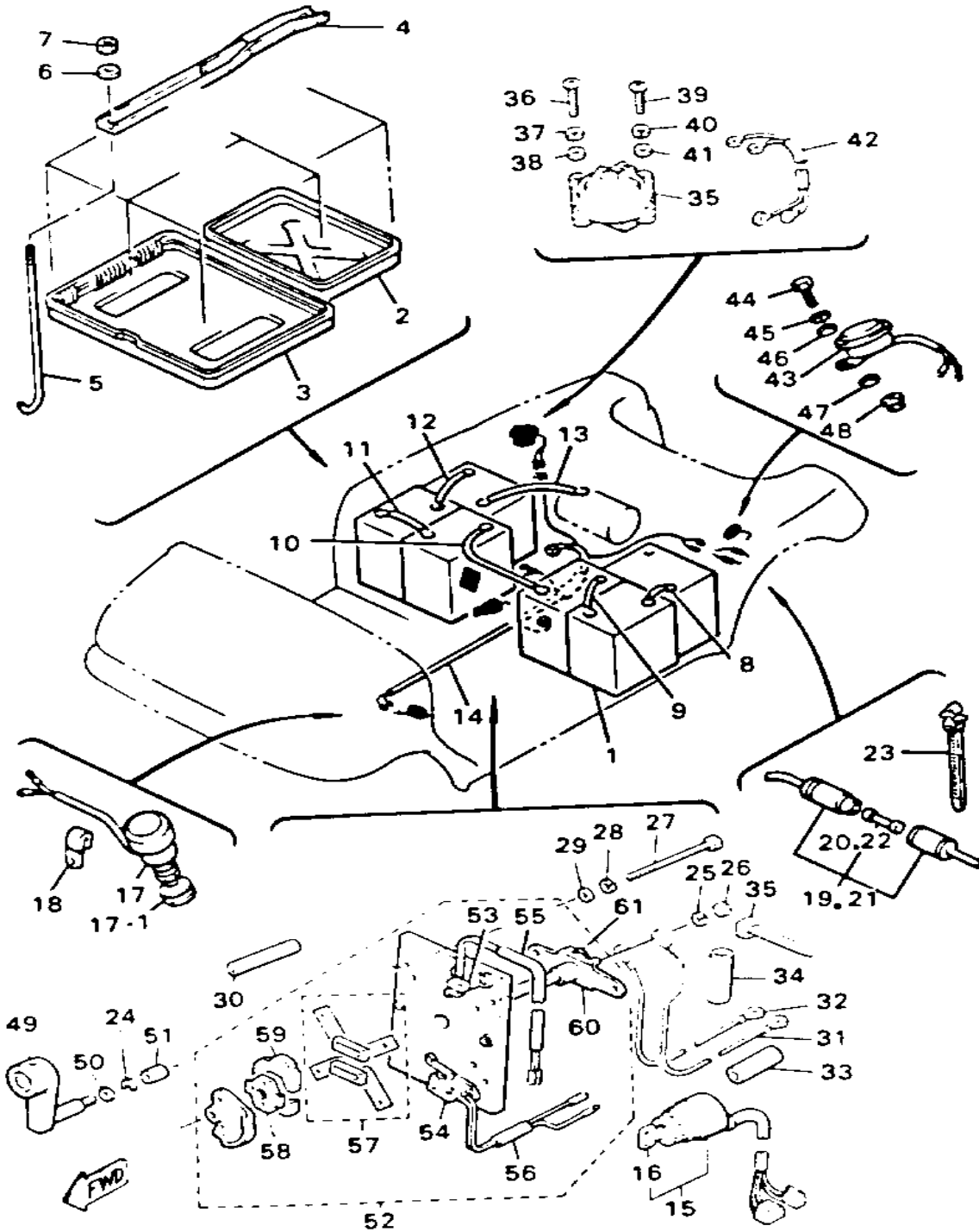

Ref. No.	Part Number	Description	Qty	Remarks
1	*---	FRONT WHEEL ASSEMBLY ..	6	LM See Note 1 See Note 2
2	J56-H2122-00-00	SEAT, BATTERY	2	See Note 2
3	J56-H2123-00-00	SEAT, BATTERY	2	See Note
38	92906-05600-00	WASHER, PLATE	2	LM See Note 1 See Note 2
17-1	JF2-82532-00-00	. CAP, RUBBER	1	See Note

ELECTRICAL 1 (G2 - E)

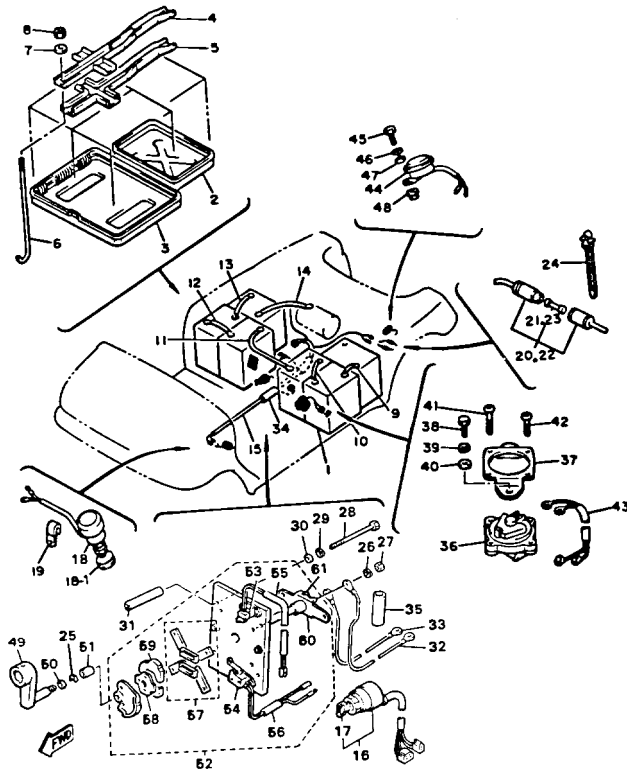

Ref. No.	Part Number	Description	Qty	Remarks
2	J56-H2122-00-00	SEAT, BATTERY	2	See Note 2
3	J56-H2123-00-00	SEAT, BATTERY	2	See Note
18	J41-82550-00-00	STOP SWITCH ASSEMBLY ...	1	See Note
41	98706-05035-	SCREW, flat head	2	

LIGHTING KIT

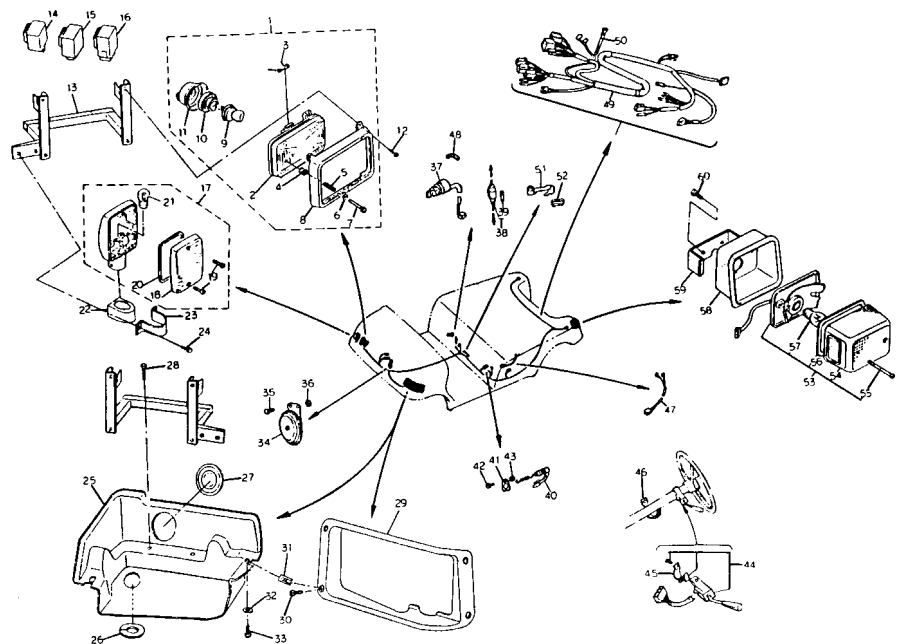

Ref. No.	Part Number	Description	Qty	Remarks
1	ϕXK-08431-00-00	. HEAD LIGHT UNIT ASS'Y	2	
2	42U-84321-60-00	. LENS ASSEMBLY	1	
3	14T-84124-00-00	. SET SPRING (5G2-84324-A0)	1	
4	198-84334-60-00	. NUT, ADJUSTING	2	
5	341-84332-60-00	. SPRING, SCREW	2	
6	233-84127-60-00	. WASHER, SPECIAL	2	
7	43F-84131-00-00	. SCREW, RIM ADJUSTER	2	
8	ϕXK-08431-50-00	. RIM, headlight	1	
9	1U4-84314-40-XX	. BULB, HEAD LIGHT (12V-45/40W)	1	
10	341-84393-40-00	. HOLDER, BULB	1	
11	46X-84396-00-00	. COVER	1	
12	ϕ97-60205-11-20	. SCREW, panhead w/w	8	
13	ϕXK-09713-10-00	. BRACKET, headlight (Left)	1	
	ϕXK-09713-20-00	. BRACKET, headlight (Right)	1	
14	33M-83350-20-00	. FLASHER RELAY ASS'Y	1	
15	J42-83350-00-00	. FLASHER RELAY ASS'Y	2	
16	J42-85590-01-00	. CONTROL UNIT ASSEMBLY	1	
17	15R-83310-70-00	. FRT FLSHR LITE ASSEMBLY (10L-83330-70)	1	
18	4G0-83312-00-00	. LENS, FLASHER	1	
19	97701-40518-00	. SCREW, TAPPING	2	
20	4G0-83313-00-00	. GASKET, FLSHR LENS	1	
21	ϕ25-68331-16-00	. BULB (12V-27W)	1	
22	ϕXK-08332-10-00	. DAMPER, flasher	2	
23	ϕXK-08336-80-00	. STAY, flasher	2	
24	ϕ97-60206-11-60	. SCREW, panhead w/w	4	
25	ϕXK-09714-90-00	. HOUSING, headlight (Left)	1	
	ϕXK-09715-00-00	. HOUSING, headlight (Right)	1	

CONTINUED ON NEXT FRAME ►

LIGHTING KIT

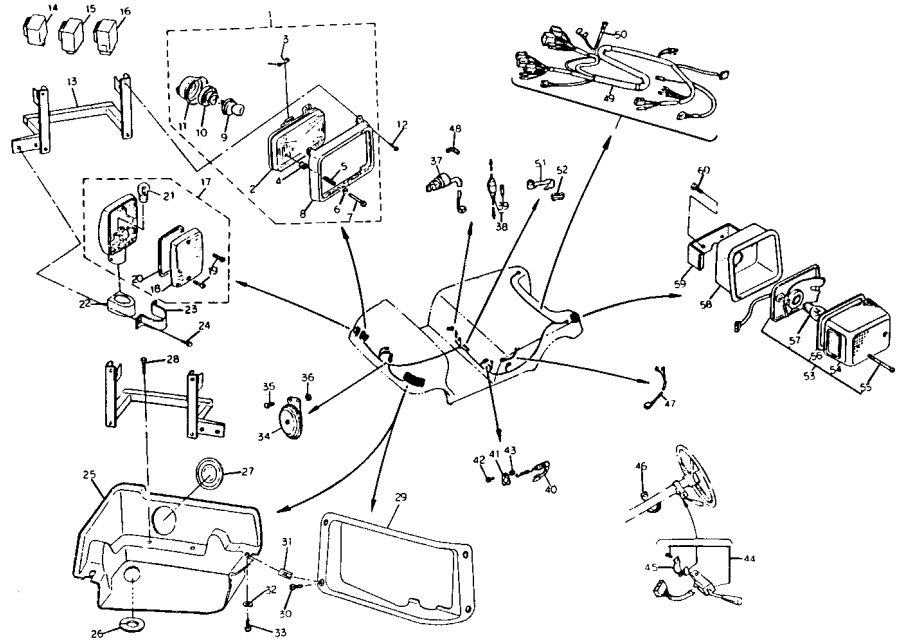

Ref. No.	Part Number	Description	Qty	Remarks
26	¢90-48024-43-90	. GROMMET	2	
27	¢XK-09714-80-00	. PLUG, headlight cover	2	
28	¢97-50206-63-50	. BOLT, hexagon head w/w	4	
29	¢XK-09711-50-00	. COVER, headlight (L)	1	
	¢XK-09711-60-00	. COVER, headlight (R)	1	
30	¢97-70650-31-60	. SCREW, oval head tapping	8	
31	90183-06035-00	. NUT, SPRING	12	
32	92990-05200-00	. WASHER, PLAIN	4	
33	97780-50120-00	. SCREW, TAPPING	4	
34	1E2-83371-21-00	. HORN	1	
35	97313-06016-00	. BOLT, HEXAGON	2	
36	95701-06500-00	. NUT, FLANGE	2	
37	¢XK-08252-00-00	. LAMP, switch ass'y	1	
38	2J2-82150-10-00	. FUSE HOLDER ASSEMBLY	1	
39	682-82151-00-00	. FUSE (20A)	1	
40	J13-82530-00-00	. STOP SWITCH ASS'Y	1	
41	J13-25656-00-00	. BRKT, STOP LT SWCHSTOP LIGHT SWITCH	1	
42	97313-06016-00	. BOLT, HEXAGON	1	
43	95701-06500-00	. NUT, FLANGE	1	
44	¢XK-08397-50-00	. SWITCH HANDLE	1	
45	¢XK-08395-50-00	. BRACKET 1	1	
46	25G-83936-01-00	. BAND, SWITCH CORD	2	
47	¢XK-08212-70-00	. WIRE LEAD 2	1	
48	J38-77742-00-00	. INDICATOR 2	1	
49	¢XK-08258-00-00	. WIRE HARNESS ASS'Y	1	
50	12R-82591-00-00	. BAND	8	
51	¢XK-08259-40-00	. CLAMP	1	
52	¢1A-02588-10-10	. PROTECTOR, brake	1	

CONTINUED ON NEXT FRAME ►

LIGHTING KIT

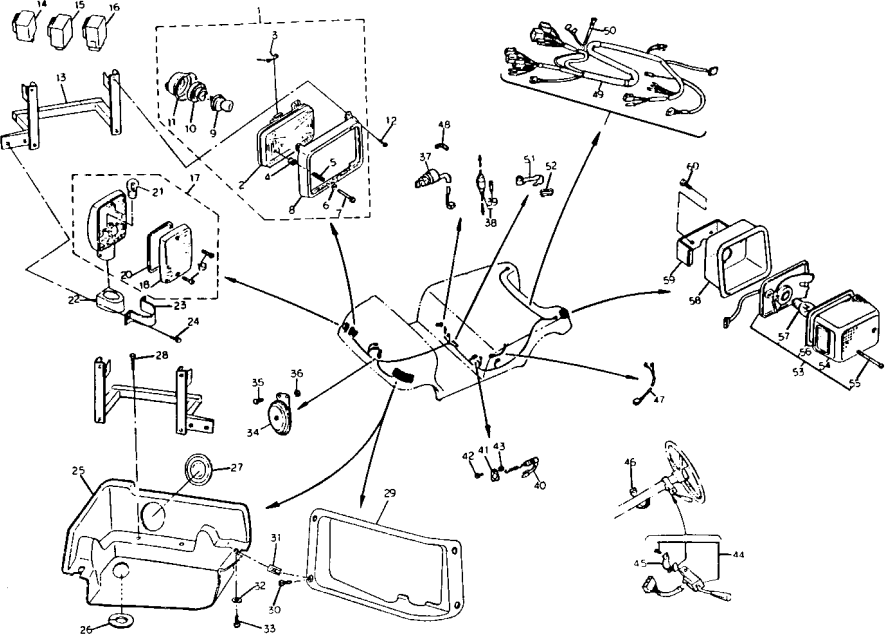

Ref. No.	Part Number	Description	Qty	Remarks
53	13W-84710-00-00	. TAILLIGHT UNIT ASS'Y	2	
54	1M8-84521-40-00	. LENS, TAILLIGHT	1	
55	1M1-84524-60-00	. SCREW, LENS FITTING	1	
56	1M1-84523-60-00	. GASKET, LENS	1	
57	256-84714-61-00	. BULB (12V-27/8W)	1	
58	ϕXK-09712-10-00	HOUSING, taillight	2	
59	ϕXK-09711-20-00	. BRACKET, taillight	2	
60	ϕ97-50206-41-60	. BOLT, hexagon head w/washer	4	

TECHNICAL BULLETIN

GOLF CAR DATE: 2/22/85 No. G85-002

G2-A, G2-E Crate Handling

The following information is presented in an effort to eliminate damage to the front cowl (and other golf car body parts) during shipping, handling and uncrating. Taking a little time up front to properly handle golf car crates will save a lot more time and money in the long run.

All assembly personnel should be made aware of these handling points.

AFFECTED UNITS

All G2-A
All G2-E

CRATE HANDLING HINTS

1. Do not lift the crate by the ends. The packed position of the front cowl cover allows its edge to protrude below the bottom bar on the crate. This being the case, any attempt to pick up the crate by the end will damage the cowl cover.

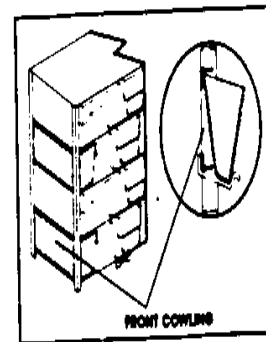
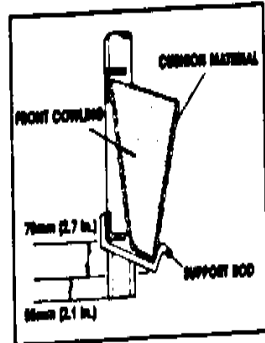

2. Do not push the crates at the ends. The front cowl cover is packed close to the thin bottom bar of the end of the crate. Therefore, any attempt to push the crate at that end will likely damage the cover.

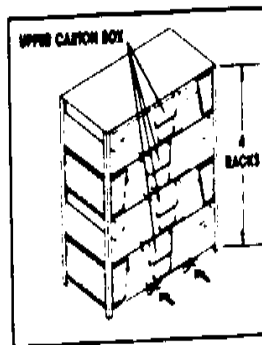

(for additional information see reverse side)

4. Lift the car from the crate carefully. The G2 is more difficult to lift from the crate because there is less clearance between the car and the crates and because the top car is higher off the ground.

If you use straps to pick up the car, be sure to position them so that no stress is placed on any plastic body panel components.

If you use a fork lift to pick up the car, be extremely careful to position the forks properly to avoid damage to either the car, you are lifting, or the one under it.

PAGE 2 OF 2

SERVICE COPY	SER MGR	MGR	MGR	MGR	INCH
OFFICE COPY	GEN MGR	SALES	PARTS	WAGER	PAGE 1 OF 2

TECHNICAL BULLETIN

GOLF CAR DATE: 5/10/85 No. G85-004A

G2-E5 DIRECTIONAL SWITCH KIT INSTALLATION

Effective 10/18/85, this Technical Bulletin replaces G85-004; please remove an obsolete G85-004. * Denotes a change in the original Technical Bulletin.

On affected units, the forward/reverse shift lever may become loose. The lever may rattle or vibrate noisily. This condition is a result of excessive clearance between the directional switch cam plate and control shaft roll pin. This condition causes accelerated wear on the cam and the eventual malfunction of the directional switch.

The replacement switch kit will hold the control shaft roll pin in place more firmly.

AFFECTED UNITS

All G2-E5 (LH)

SUMMARY OF SWITCH KIT PARTS

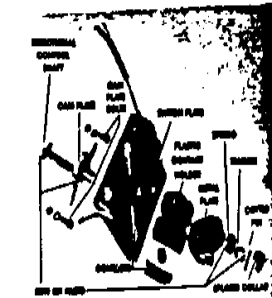

SERVICE PROCEDURES

1. Turn off the main switch and remove the key.
2. Lock the parking brake. Also, make sure the directional control lever is in the "FORWARD" position.
3. Disconnect the negative battery lead from the battery pack to the motor (A2 terminal).

WARNING

Place non-conductive material, like a plywood board approximately 18" x 24", over the battery bay. In addition to the safety benefits, this board can serve as a mini-work bench.

SERVICE COPY	SER MGR	MGR	MGR	MGR	INCH
OFFICE COPY	GEN MGR	SALES	PARTS	WAGER	PAGE 1 OF 4

6. Lift off the switch assembly and lay it back on the plywood. Also, remove the internally splined lever collar.



8. Remove the directional control shaft and cam plate while holding the assembly together exactly as it came off the body panel.



7. While holding the switch assembly together, remove the cotter pin, washer, and spring on the contact side of the assembly.

NOTE: Be sure to keep the components of the assembly together exactly in position.



9. Continue to grasp the assembly components firmly and install the new cam plate and new directional control shaft.

NOTE: Align the keyways grooved into the control shaft with the matching keys on the metal plate (contact side) and then push the shaft through the assembly. Also, the control shaft roll pin must be put into the "FORWARD" position cam slot.

10. Install the new spring, old washer, and new cotter pin onto the shaft.

PAGE 2 OF 4

TECHNICAL BULLETIN

GOLF CAR DAY: 5-10-85 BY: G85-004A

11. Split and bend the new cotter pin perpendicular to the shaft so the pin will not interfere with the splined lever collar.



12. Turn the slot on the directional control lever to the "NEUTRAL" position.

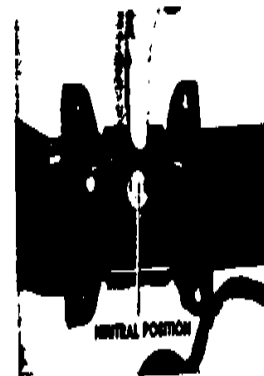

13. Carefully reinstall the internally splined lever collar so as not to disturb the position of the directional control lever slot.

14. Turn the control shaft roll pin from the "FORWARD" position to the "NEUTRAL" position to align with the lever slot (step 12).



15. Align the switch assembly with the mounting holes and push the assembly (splined end first) into the splined lever collar.

16. Reinstall the assembly onto the body panel with the four long bolts and spacers.

17. Reinstall the cam plate bolts, washers, and nuts. Grease the cam plate, where the roll pin contacts the cam plate, with molybdenum disulfide grease.

18. Reconnect the negative battery lead from the battery pack to the motor.

WARRANTY

You will receive a preprinted Factory Modification Notice as shown below for each involved unit. The warranty labor allowance for this procedure is 0.3 hours. The Factory Modification Code is 859906. To receive credit for the parts and labor involved in this modification, submit the completed Factory Modification Notice to

the Warranty Department; make sure that the card has been signed by the dealer, and that all appropriate information has been filled in. If you do not have a Factory Modification Notice, contact the Golf Car Program Coordinator for help at (714) 761-4393.

YAMAHA		FACTORY MODIFICATION NOTICE	
MODEL NO.	859906	DATE	
UNIT NO.	000000	DEALER	
DATE		ADDRESS	
MOTOR DEALER BY		NAME	
G.C. Reim & Sons		1111 Main Street, OMA 50000	
DEALER NAME		ADDRESS	
000000		1111 Main Street, OMA 50000	
ADDRESS		CITY STATE ZIP	
000000		00000	
CITY STATE ZIP		MILEAGE	
<input type="checkbox"/> COMPLETELY NEW UNIT <input type="checkbox"/> PART OF PREVIOUS YEAR'S INVENTORY <input type="checkbox"/> PRODUCT HAS BEEN REWORKED <input type="checkbox"/> PRODUCT HAS BEEN REWORKED AND IS A RETURN UNIT WITH NO OTHER DEFECTS			
APPROVED BY		DATE	
SERVICE SHOP SIGNATURE		MILEAGE	

PAGE 4 OF 4

PARTS INFORMATION

PART NUMBER	DESCRIPTION	REMARKS	QTY	DEALER COST
J41-82501-00-00	Replacement Switch Kit	Includes: Cam plate Spring Cotter pin Control shaft	1 1 1 1	

PAGE 3 OF 4

(For additional information see reverse side)

TECHNICAL BULLETIN

GOLF CAR DAY: 7-12-85 BY: G85-007A

G2-A; G2-E STEERING SQUEAK

Effective 10-18-85, this Technical Bulletin replaces G85-007, please remove and destroy G85-007. Denotes a change in the original Technical Bulletin.

Squeaking sounds can occur when turning the steering wheel of an affected unit. This condition is a result of the lack of grease on the rubber bushing located in the steering column. To correct this condition, follow the service procedures set forth in this bulletin.

AFFECTED UNITS

G2-A J38 000101 ~ 000431
G2-E J41 000101 ~ 003571

SERVICE PROCEDURES

1. Remove the scorecard holder.
2. Loosen the nut that holds the steering wheel to the tapered shaft inside the steering column about three turns.

WARNING

Do not remove the nut completely. The steering wheel hub hugs the tapered shaft tightly. As a result, loosening the steering wheel from the shaft will take extreme effort. Therefore, it is important for the nut to remain on the steering column, in a loosened condition, until after step 3.

3. Pop the steering wheel loose from the tapered shaft by grasping both sides of the steering wheel (near the cross bars) and rocking the wheel from side to side while pulling outward. The wheel should pop off the shaft but still be kept from coming completely off the steering column by the nut.

4. Remove the nut and steering wheel and look for the "high spots" on the rubber bushing which indicate the location of the spacing ribs on the bushing.

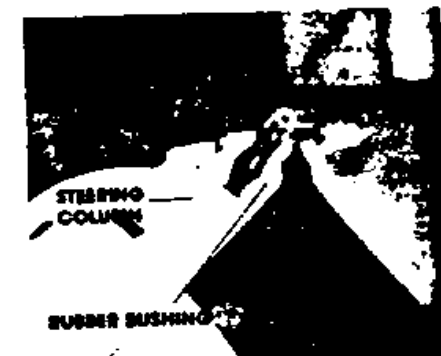

5. Remove the rubber bushing by lifting the thin collar and inserting a blade screwdriver between the ribs gently prying upward. Repeat this procedure on the opposite side of the bushing until it is removed.



(For additional information see reverse side)

APPROVED BY: _____ DATE: _____
SERVICE SHOP SIGNATURE: _____ DATE: _____
MILEAGE: _____
PAGE 1 OF 2

TECHNICAL BULLETIN

GOLF CAR DATE: 8/23/85 BY: G85-009

G2 MODELS BODY PAINTING

Some customers may want to have painted golf cars for a personalized, custom appearance. Unless the surface is correctly prepared and painted, however, the paint will not adhere to the body properly. This bulletin provides the recommended procedure for preparation and painting of G2 model polypropylene body parts.

designed for polypropylene, which should be available at auto paint supply outlets. Be sure the primer is completely dry before applying the finish coat of paint. This step is extremely important for successful painting.

4. Apply the color coat of paint. Only a high quality, acrylic-based automotive paint or urethane should be used.

NOTE: The paint should be flexible by design to avoid cracking when the parts bend during normal use. Add a flex agent to the paint if necessary.

AFFECTED UNITS

All G2 cars

PAINTING PROCEDURES

1. Degrease the parts to be painted. polypropylene naturally has an oily coating which must be removed. Wet a cloth with 100-quer thinner (toluene would also be acceptable) and wipe the area three or four times. Dry the area with a clean cloth.

2. Prepare the parts by wiping them with toluene. This chemically treats the surface to make the paint adhere better. Dry the parts again with a clean, lintless cloth.

NOTE: Toluene is not available at all paint supply outlets, and you may have to contact several places before you find it. It is more commonly found in the paint section of hardware stores than in automotive paint supply outlets.

3. Prime the parts with a primer specifically

CAUTION:

The temperature of the polypropylene material must not exceed 176° F (80°C) or the material may distort. The paint can also be dried at normal air temperature. Drying time will take one to two weeks, depending on temperature, humidity, etc. Care must be used during the drying time, because the paint will be easy to scratch or mar.

6. If a clear coat is also to be applied, follow the same procedure that was used to apply the color coat.

6. Thoroughly grease the grooved area inside the bore of the bushing with molybdenum disulfide grease.

7. Reinstall the bushing into the steering column.

8. Reinstall the steering wheel onto the tapered shaft, and reinstall the nut.

NOTE: Be sure the front wheels are straight, and the cross bars of the steering wheel form a "Y" as viewed from the driver's seat. Also be sure the two drain holes in the hub are on the bottom of the hub. Then tighten the nut. Torque the nut to 3.3 m-tg (24 ft-lbs).

9. Reinstall the scorecard holder.



PARTS INFORMATION

PART NUMBER	DESCRIPTION	REMARKS	DEALER COST
38-23814-00-00	Rubber Bushing	Replace only if damaged	

WARRANTY

You will receive a preprinted Factory Modification Notice as shown below for each invoiced unit. The warranty labor allowance for this procedure is 0.11 hours. The Factory Modification Code is 859902. To receive credit for the labor involved in this modification, submit the completed Factory Modification Notice to the War-

ranty Department. Make sure that the card has been signed by the dealer, and that all appropriate information has been filled in. If you do not have a Factory Modification Notice, contact the Golf Car Program Coordinator for help at (714) 761-0392.

YAMAHA

FACTORY MODIFICATION NOTICE

DATE: 08-23-85 859902

SALES & SERVICE

10000 Main Street, SA 95000

10000 Main Street, SA 95000

10000 Main Street, SA 95000

PAGE 2 OF 2

SALES DEP.	SALES	MECH.	MECH.	MECH.	MECH.	MECH.

PAGE 1 OF 1

TECHNICAL BULLETIN

GOLF CAR DATE: 8/23/85 BY: G85-010

G2-E DIFFERENTIAL PIN EXCHANGE

It has been determined that the differential pin on the affected units is wearing prematurely. The pin is not hard enough to withstand its load. Excessive play in the drive train has resulted from this condition, causing erratic operation.

This condition may be remedied by the installation of a new, hardened pin with oil retention areas.

AFFECTED UNITS

All 1985 G2-E

SERVICE PROCEDURES

NOTE: Normal differential repair procedures (found in the service manual) are acceptable for this exchange. However, the procedures in this bulletin may help save setup time.

1. Block the front wheels so that the car cannot roll forward. Jack-up the car at the center of the crossbar on the rear arm. Using jackstands, support the frame of the car just in front of the rear wheels.

2. Remove the rear body panel.

WARNING

Before going on to step 3, disconnect the negative lead from the battery to the motor.

3. Remove the heavy electrical wire connecting the drive motor to the speed control.

4. Remove the drive motor from the car.

NOTE: Plug or pinch off the transmission vent tube of the part.

5. Remove only the left-side brake cable.

6. Remove the bolt connecting each shock to the axle housing, and allow the jack to lower the rear arm until the wheels touch the floor.

7. Remove the six bolts holding the right-side axle housing to the transmission assembly.

8. Remove the four bolts holding the left-side axle housing to the rear arm.



9. Remove the transmission left axle-wheel assembly from the car.

NOTE: The transmission's left-axle wheel assembly may then be placed on the wheel, which can act as a stand to support the transmission during disassembly.



10. Remove the right cover from the transmission, and remove the differential assembly.

12. Clean the inside of the transmission case and bearings if there is substantial wear on the pin, or if there is residue in the case.

13. Disassemble the differential assembly and replace the pin.

NOTE: Drive out the spring pin with a 3mm (1/8 in) drift punch.

14. If the serial number of the car is 002780 or lower, install a Dowel Pin kit, and use the new flange bolts included in that kit. Discard the old flange bolts and dowel pins.

NOTE: Apply a thread locking compound to the bolt threads.

TIGHTENING TORQUE FOR FLANGE BOLTS: 3.8 kgm (27 ft lbf)

PARTS INFORMATION

PART NUMBER	DESCRIPTION	REMARKS	DEALER COST
00891-60028-00	Differential Pin Kit	Kit includes: 1 differential pin 1 spring pin 1 gasket 2 cotter pins	
00891-60029-00	Dowel Pin Kit	Kit includes: 2 dowel pins 4 flange bolts Use only for cars with serial #002780 or lower	

PAGE 2 OF 3

SALES DEP.	SALES	MECH.	MECH.	MECH.	MECH.	MECH.

PAGE 1 OF 3

TECHNICAL BULLETIN

GOLF CAR DATE 10-4-85 BY G45-010

WARRANTY

You will receive a preprinted Factory Modification Notice as shown below for each invoiced unit. The warranty labor allowance for this procedure is 2.0 hours. The Factory Modification Code for units with serial numbers from 800191-802790 is 809907; the Modification Code for units with serial numbers above 802790 is 809908. To receive credit for the parts and

labor involved in this modification, submit the completed Factory Modification Notice to the Warranty Department, make sure that the card has been signed by the dealer and that all appropriate information has been filled in. If you do not have a Factory Modification Notice, contact the Golf Car Program Coordinator for help at (714) 761-7393.

GOLF CAR DATE 10-18-85 BY G45-012

G2-E SOLENOID REPLACEMENT

Accelerated testing at the factory has shown that the solenoids on affected units may fail after two or three years of heavy use. The solenoid fails when the sponge portion of the sponge nut breaks. This allows the contact plate to become loose.

Replacement solenoids, now available from YPEI, have improved nuts with separate washers which have proven completely reliable in the same accelerated testing.

AFFECTED UNITS

G2-E J41-00101 - 00160

PARTS INFORMATION

NOTE: Order parts for this program only by calling the Golf Car Coordinator at 714-761-7393.

PART NUMBER	DESCRIPTION	REMARKS	DEALER COST
J41-81950-00-00	Solenoid	Has improved nut. Use Solenoid from batch number 502 or higher	

SERVICE PROCEDURE

1. Replace the original solenoid on the affected units.

NOTE: For actual solenoid replacement procedures, please refer to the Service Manual (J1-11616-G4-P1).

YAMAHA FACTORY MODIFICATION NOTICE

G2-E5 819907

DATE: 10-4-85 BY: G45-010

DEALER: G.C. Sales & Serv. 1111 Main Street, OMA 90000

Municipal Coach 1111 Main Street, OMA 90000

YAMAHA FACTORY MODIFICATION NOTICE

G2-E5 819908

DATE: 10-4-85 BY: G45-010

DEALER: G.C. Sales & Serv. 1111 Main Street, OMA 90000

Municipal Coach 1111 Main Street, OMA 90000

PAGE 3 OF 3

WARRANTY

You will receive a preprinted Factory Modification Notice as shown below for each invoiced unit. The warranty labor allowance for this procedure is 0.2 hours. The Factory Modification Code is 809909. To receive credit for the parts and labor involved in this modification, submit the completed Factory Modification Notice to

the Warranty Department, make sure that the card has been signed by the dealer, and that all appropriate information has been filled in. If you do not have a Factory Modification Notice, contact the Golf Car Program Coordinator for help at (714) 761-7393.

YAMAHA FACTORY MODIFICATION NOTICE

G2-E5 819909

DATE: 10-18-85 BY: G45-012

DEALER: G.C. Sales & Serv. 1111 Main Street, OMA 90000

Municipal Coach 1111 Main Street, OMA 90000

SERVICE CODE	ISS. NO.	REV.	REV.	REV.	REV.	PAGES
SERVICE CODE	ISS. NO.	REV.	REV.	REV.	REV.	PAGE 1 OF 1

TECHNICAL BULLETIN

GOLF CAR DATE 10-18-85 BY G45-013

G2 SEAT LATCH

Some seats on the affected units may tilt forward without releasing the latch. To correct this, the kit described below must be installed.

AFFECTED UNITS

All 1985 G2-A
All 1985 G2-E

NOTE: G2-A affected units with serial numbers lower than J38-002979 and G2-E affected units with serial numbers lower than J41-005119 must receive the new seat latch kit. For these units begin at step 2 of the Service Procedures.

For affect units with serial numbers higher than those listed above begin at step 1 of the Service Procedures.

SERVICE PROCEDURES

1. Check the latch security by firmly grasping

the handrail on the driver's side of the car, and lift forcefully. If the seat swings forward, the latch and rubber stoppers must be replaced.

NOTE: If the seat does not swing forward, the latch and stoppers are satisfactory. Do not replace them. No further work is required on this car. Do not continue with the procedures in this bulletin.

2. Remove the original rubber stoppers from the supports and discard them. Apply adhesive (3M #76 or equivalent) to the new stoppers and install them on the metal supports.

3. Remove the old latch components and discard them. Install the new latch components.

4. Recheck the latch as in step 1.

PARTS INFORMATION

NOTE: Order parts for this program only by calling the Golf Car Coordinator at 714-761-7393.

PART NUMBER	DESCRIPTION	REMARKS	DEALER COST
90891-60026-00	Latch kit		

WARRANTY

You will receive a preprinted Factory Modification Notice as shown below for each invoiced unit. The warranty labor allowance for this procedure is 0.1 hours. The Factory Modification Code is 859903. To receive credit for the parts and labor involved in this modification, submit the completed Factory Modification Notice to

the Warranty Department, make sure that the card has been signed by the dealer, and that all appropriate information has been filled in. If you do not have a Factory Modification Notice, contact the Golf Car Program Coordinator for help at (714) 761-7393.

YAMAHA FACTORY MODIFICATION NOTICE

G2-E5 859903

DATE: 10-18-85 BY: G45-013

DEALER: G.C. Sales & Serv. 1111 Main Street, OMA 90000

Municipal Coach 1111 Main Street, OMA 90000

SERVICE CODE	ISS. NO.	REV.	REV.	REV.	REV.	PAGES
SERVICE CODE	ISS. NO.	REV.	REV.	REV.	REV.	PAGE 1 OF 1

WARRANTY

You will receive a preprinted Factory Modification Notice as shown below for each invoiced unit. The warranty labor allowance for this procedure is 0.1 hours. The Factory Modification Code is 859912. To receive credit for the parts and labor involved in this modification, submit the completed Factory Modification Notice to

the Warranty Department, make sure that the card has been signed by the dealer, and that all appropriate information has been filled in. If you do not have a Factory Modification Notice, contact the Golf Car Program Coordinator for help at (714) 761-7393.

YAMAHA FACTORY MODIFICATION NOTICE

G2-E5 859912

DATE: 10-18-85 BY: G45-013

DEALER: G.C. Sales & Serv. 1111 Main Street, OMA 90000

Municipal Coach 1111 Main Street, OMA 90000

PAGE 2 OF 3

TECHNICAL BULLETIN

GOLF CAR DATE 10/18/85 NO. G85-014

G-2 BODY PANEL EXCHANGE

Due to breakage of the body panel material installed on the affected units, the body panels must be exchanged for panels made of an improved material.

This bulletin describes an order of procedures that will aid in efficient utilization of time and manpower during completion of the body panel exchange.

AFFECTED UNITS

All 1985 G2A
All 1985 G2E

SERVICE PROCEDURE

NOTE: Use of compressed air power tools will greatly decrease the time necessary to complete this procedure.

NOTE: While this job can be completed on a one-man, one-car basis, it may prove to be more efficient to have two-man teams working on each car.

1 Wash the car. Be sure to clean under the body parts as well.

2 If the car has a sun roof, remove it as an assembly and set it aside. Lifting the roof will usually require two men.

3 Remove all body panels and floor mats. Organize the removed hardware (screws, etc.) so that it will be easy to find later.

4 Remove the aluminum trim and YAMAHA name plate from the front body panels.

5 Check the serial number of the car and compare it to those listed in other bulletins to see if it needs other work. If it does, now is the best time to complete it, while the body panels are off and the car is clean.

6 Install the floor mats. Apply double-sided tape

to the rubber mat part of the inspection plate. Install the mat onto the plate. Secure the mat with the rivets supplied, being sure to install the new spacer collars through the mat first.

Install the inspection lid onto the car.

Apply double-sided tape to the underside of the other floor mats and to the floor of the car. Carefully position the floor mats and place them on the car. Secure them with the supplied rivets, being sure to install the new spacer collars through the mat first.

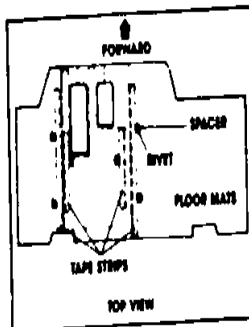

7 Install the aluminum trim and YAMAHA name plate onto the new front body panels. Be sure to install the small flat washer onto the rivet before setting it.

8 Install the new body panels and other removed parts onto the car.

NOTE: Before installing the mid body and rear body panels, loosen the three bolts holding the fuel tank in place. Push down hard on the fuel cap and retighten the bolts while still pushing down on the fuel cap. Install the new fuel cap.

Whenever there is a screw, nut, or washer that touches a painted surface, install one of the proper plastic washers between it and the painted surface.

9 If a sunroof was removed from the car, reinstall it now.

PARTS INFORMATION

Order body parts for this program ONLY by calling 714 761-7393.

The body panels are shipped in quantities of four. Minor parts (screws, rivets, etc.) are shipped in quantities of 10 per normal procedure. Other parts, such as mats, inspection covers, etc. are included in quantities that correspond to the total number of kits ordered.

TOOL INFORMATION

The tools listed in this section are furnished by Yamaha Motor Corporation, USA.

- 3/8" air wrench
- 3/8" air angle drive or wrench
- 3/8" drive Phillips screwdriver
- 3/8" impact socket set
- 5/8" air hose

WARRANTY

You will receive a preprinted Factory Modification Notice as shown below for each invoiced unit. The warranty labor allowance for this procedure is 2.1 hours. The Factory Modification Code is 859910. To receive credit for the parts and labor involved in this modification, submit the completed Factory Modification Notice to

the Warranty Department, make sure that the card has been signed by the dealer, and that all appropriate information has been filled in. If you do not have a Factory Modification Notice, contact the Golf Car Program Coordinator for help at (714) 761-7393.

PAGE 2 OF 3

DATE	TIME	BY	NO.	PAGE
				PAGE 1 OF 3

TECHNICAL BULLETIN

GOLF CAR DATE 10/18/85 NO. G85-014

GOLF CAR DATE 10/18/85 NO. G85-016

G2-E BATTERY HOLDER KIT

NOTE: Instead of retaining the entire body panels for 90 days as per normal warranty verification procedures, you should only retain clippings cut from certain areas on the panels. Diagrams of where to cut out these clippings are attached.

REAR BODY PANEL

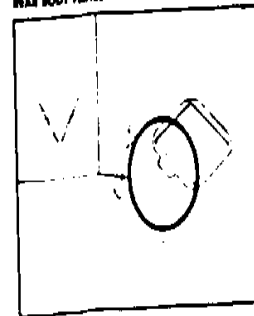

FRONT UPPER COWL

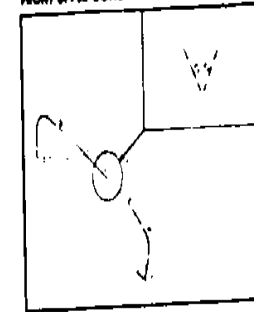

INTERMEDIATE BODY

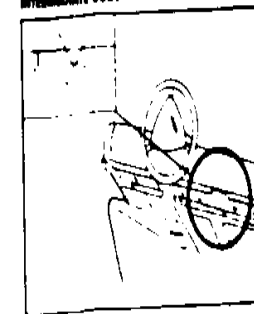

FRONT LOWER COWL

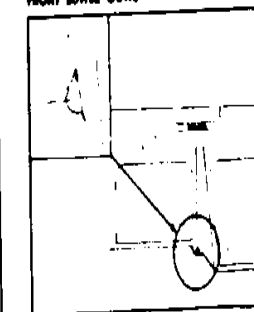

PAGE 3 OF 3

The batteries on the affected units may ground slightly. To remedy the situation, the factory has developed a new battery holder kit.

AFFECTED UNITS

All 1985 G2-E

SERVICE PROCEDURES

1. Remove the front nut holding the securing bar in place.
2. Check the bar to be sure that it is not bent. If it is, remove it from the car and carefully straighten it.
3. Insert the added cross brace into the new rubber pad, and insert the pad under the existing bar.

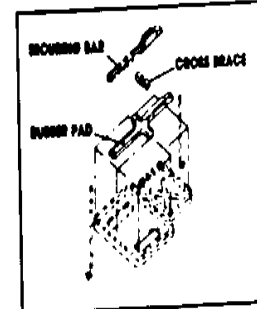

4. Reinstall the bar. Do not overtighten the nuts holding the bar, as this will bend the bar.

PARTS INFORMATION

NOTE: Order parts for this program only by calling the Golf Car Coordinator at (714) 761-7393.

PART NUMBER	DESCRIPTION	REMARKS	DEALER COST
8094-60027-00	Battery Holder Kit		

WARRANTY

You will receive a preprinted Factory Modification Notice as shown below for each invoiced unit. The warranty labor allowance for this procedure is 0.1 hours. The Factory Modification Code is 859910. To receive credit for the parts and labor involved in this modification, submit the completed Factory Modification Notice to

the Warranty Department, make sure that the card has been signed by the dealer, and that all appropriate information has been filled in. If you do not have a Factory Modification Notice, contact the Golf Car Program Coordinator for help at (714) 761-7393.

SERVICE COPY	88 5428	MECH	MECH	MECH	MECH
OFFICE COPY	004 5428	SALES	SALES	SALES	PAGE 1 OF 1

TECHNICAL BULLETIN

GOLF CAR DAY 10/18/85 BY G85-017

GOLF CAR DATE 10/10/85 BY G86-008

G2 SEAT COVER INSPECTION

Some seats on affected units may develop open seams on the front corners, due to a faulty vinyl welding process. These seats are to be inspected for separation and replaced on a "case-by-case" basis.

Some seats may appear to be opening up, but in fact are only showing a characteristic of a welded vinyl seam under stress. The first section of the weld, which does not reach as high a temperature as the main weld, may open partially. However, when the spreading reaches the main portion of the weld, separation will usually stop. Seats with seams that are only partially open are not to be replaced.

PARTS INFORMATION

NOTE: Order parts for this program by calling the Golf Car Coordinator at (714) 761-7393.

PART NUMBER	DESCRIPTION	REMARKS	DEALER COST
J38-78401-01-00	Seat Assembly		

WARRANTY

You will receive a preprinted Factory Modification Notice as shown below for each invoiced unit. The warranty labor allowance for this procedure is 0.1 hours. The Factory Modification Code is 859904. To receive credit for the parts and labor involved in this modification, submit the completed Factory Modification Notice to

the Warranty Department; make sure that the card has been signed by the dealer, and that all appropriate information has been filled in. If you do not have a Factory Modification Notice, contact the Golf Car Program Coordinator for help at (714) 761-7393.

SERVICE COPY	GEN MGR	MECH	MECH	MECH	INCR
OFFICE COPY	SALES	PARTS	INCR		PAGE 1 OF 1

G2-E IMPROVED RIDE QUALITY

Some of the G2-Es were sent from the factory with incorrect toe-in. Due to suspension design, toe-in adjustment has a direct effect on shock absorber travel. This adjustment procedure increases the travel and improves the ride.

AFFECTED UNITS

All 1985 G2-E J41-000003~006440 and 1986 G2-E J41-04101-020120

SERVICE PROCEDURES

INSPECTION

1. Park the vehicle on a level surface and position the wheels straight ahead.
2. Measure the distance between the same point and height on the front and rear of the front tires. For example, this point can be the center tread or inside edges of both tires. Front measurement should be less than rear measurement.
3. Subtract the front measurement from the rear measurement to find the toe-in. Proper toe-in is 9.0 ± 5 mm.

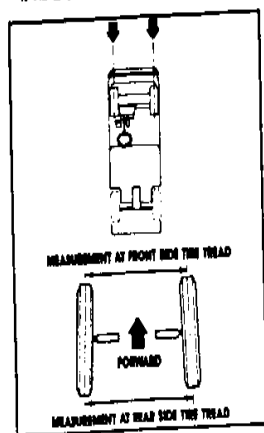

ADJUSTMENT

If adjustment is necessary, proceed as follows:

4. Loosen the two adjustment locknuts on the ends of the left and right tie rods. Left side locknuts are left-hand thread and are loosened by turning them clockwise.
5. Adjust each tie-rod equally until the toe-in is correct.
6. Tighten the locknuts and torque them to 35 ft-lb (4.8m-tq).
7. Test drive to confirm proper operation.

WARRANTY PROCEDURE

The warranty labor allowance for this procedure is 0.3 hours. The problem code is 90H1. To receive credit follow standard service-per-bulletin procedures. There is no warranty allowance for inspection.

90H1

90H1 problem code used description on label

SERVICE COPY	GEN MGR	MECH	MECH	MECH	INCR
OFFICE COPY	SALES	PARTS	INCR		PAGE 1 OF 1

TECHNICAL BULLETIN

GOLF CAR DATE 11/19/87 BY G87-005

GOLF CAR DATE 2/11/88 BY G88-002

G2-A/G2-E PRIMARY ID FRAME LOCATION CHANGE

INTRODUCTION

The placement of the stamped-in Primary ID number on the vehicle frame has been changed. See the illustrations for the new locations.

NOTE: The G2-A engine number location remains the same.

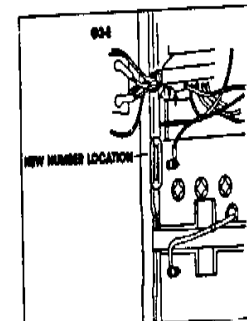
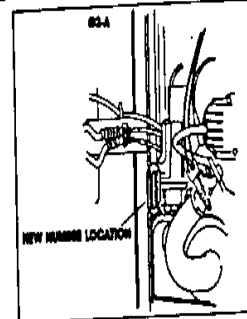

DEALER ACTION SUMMARY

No dealer action required. This bulletin is issued only to inform you of the change in ID number location.

STARTING ID NUMBERS

G2-A J38-072306
G2-E J41-053401

WARRANTY INFORMATION

Warranty is not affected.

ROUTE TO: SERVICE PARTS WARRANTY SALES PAGE 1 OF 1

G2 SEAT COVER INSPECTION AND REPAIR

INTRODUCTION

PROBLEM: Hole in the seat cover on the side by the driver's side armrest.

CAUSE: Some of the staples used to secure the seat cover to the seat base near the armrest mount may wear through the seat foam and puncture the cover.

REMEDY: Remove the staples and or replace the seat cover if it is damaged by incorrect staple placement.

DEALER ACTION SUMMARY

For units with no seat cover damage, both new unaltd units and units already in service, remove the staples near the armrest side of the seat as shown in this bulletin. For sold and registered units with seat cover damage

caused by incorrect stapling, replace seat cover. Use 1/4" stainless steel staples when installing new cover. Follow standard 90 code procedure to file a warranty claim.

AFFECTED UNITS

G2AM5 J38-000101 ~ 036999
G2A J38-007101 ~ 049999,
J38-066101 ~ 070999
G2AB J38-022101 ~ 039999

G2EM5 J41-000101 ~ 009999
G2E J41-046101 ~ 029999
G2EB J41-030101 ~ 033501

SERVICE PROCEDURE

WARNING

Wear proper eye protection when performing the procedure described in this bulletin.

Staple Removal Only (if no damage is present)

NOTE: Additional pre-delivery service: pull driver's side staple before assembling new units within the affected range.

1. Raise the seat covering.
2. Open the mid-body and remove the 2 bolts securing left side of the seat to the base. Flex the seat base far enough to remove the staples near the arm rest mount on the driver's side.
3. Remove only the staple in the affected arm rest mounting area on the seat base.
4. Reinstall the seat.

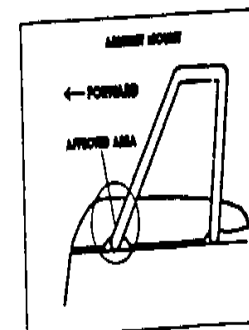

TECHNICAL BULLETIN

SERVICE PROCEDURES (Cont'd)

Damaged Seat Cover Replaced

1. Remove the seat covering.
2. Remove the seat.
3. Cut the seat cover between the staples and the seat base edge.



4. Use pliers to pull up the vinyl. When the vinyl is pulled up sharply, most of the staples will be pulled out. Remove any remaining staples in corners and arm rest mounting area. Discard the old seat cover.

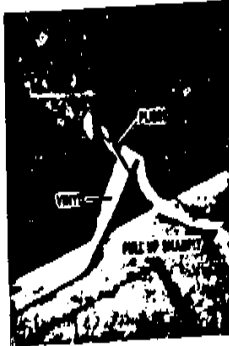

5. Position and center the new seat cover. Staple the center of the front, rear, left, and right sides to the seat base with a pneumatic or electric staple gun.

6. Fold and staple the corners. Install all other staples (front, back, and sides).

7. Staple the original clipped area of the new angle shown in the illustration.

Do not duplicate the original problem.

8. Trim off the excess material.

9. Reinstall the seat.

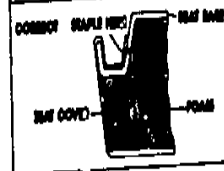
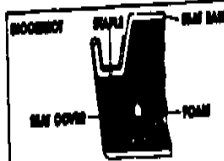

GOLF CAR DATE 2/11/88 RA G-002

SERVICE PROCEDURES (Cont'd)

PARTS INFORMATION

Part Number	Description	Remarks	Dealer Cost
J36-78404-09-00	Seat cover 1/4" Stainless steel staples	Obtain from hardware store	

WARRANTY INFORMATION

Staple Removal Only

For new unacid units and registered units with no holes (damage) labor allowance is 0.1 hour.

90JE1 0.1
(If this problem can not be resolved by repair) HOUR RATE

Seat Cover Replacement (includes staple removal)

Labor allowance for seat cover replacement is 0.5 hours. Unit must be registered. Yamaha will not reimburse for claims on unregistered units in service or on units registered after 3-31-88.

90JE2 0.5
(If this problem can not be resolved by repair) HOUR RATE

ROUTE TO: SERVICE PARTS WARRANTY SALES PAGE 3 OF 3

TECHNICAL BULLETIN

GOLF CAR DATE 3/17/88 RA G48-003

G2-A/G2-E SOLENOID REPAIR KIT

INTRODUCTION

PROBLEM: Solenoid plunger moves, but solenoid does not operate.

CAUSE: Internal moving parts or contacts worn or damaged.

REMEDY: Install solenoid repair kit.

NOTE: If the solenoid coil is bad, the complete solenoid must be replaced. (The solenoid coil

is bad if the solenoid plunger does not move when power is applied directly to the solenoid coil wires, or if there is no continuity between the two solenoid coil wires [measured with an ohmmeter with the battery cables and wire harness disconnected].

If the coil is good, the ohmmeter should read $62\Omega \pm 10\%$ (J-41) or $72 \pm 10\%$ (J-38). Any higher readings indicate a shorted or grounded coil.

DIAGNOSTIC ACTION SUMMARY

If a solenoid's plunger moves, but the solenoid does not operate properly, a repair kit may be

installed, using the service procedures in this bulletin.

AFFECTED UNITS

All G2-A J38
All G2-E J41

SERVICE PROCEDURES

Turn the main switch off, and disconnect the negative battery lead. Secure the battery lead so it cannot contact the battery terminal, and remove the solenoid.

NOTE: Refer to the PARTS INFORMATION section to view all parts named in the following procedure.

DISASSEMBLY

1. Remove the cover screws and loosen the end cap.

CAUTION:

Do not try to remove the cap at this point. The coil wires are still attached and will easily break if any strain is put on them.



DISASSEMBLY (Cont'd)

2. Heat the terminals at the top of the cap to melt the solder that holds the coil wires. Only when the solder is fluid, pull upward on the cap and allow the wires to slip out. Discard the old cap and seat.

CAUTION:

Do not pull on the end cap until the solder has melted. The coil wires will break.

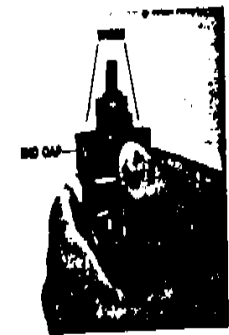

3. Remove the rubber cover, and underneath, the two screws, the plate, and the two coils.

4. Remove the contact plate by removing the small nut holding it to the shaft and plunger assembly.



5. Discard the plunger shaft, and contact plate and parts. Keep the large spring and insulator for use in reassembly.

REASSEMBLY

WARNING:

Failure to follow these reassembly and plunger adjustment instructions properly can cause the solenoid to engage by itself, with the following possible consequences:

- ELECTRIC CAR - WITH BRAKE ON:** Overheating of the resistor coils and motor, resulting in serious damage to these components.
- ELECTRIC CAR - WITH BRAKE OFF:** The car may move without an operator.
- GAS CAR - WITH BRAKE ON OR OFF:** The starter motor will operate without the accelerator pedal being pressed. Under certain conditions, the car can move without an operator.

TECHNICAL BULLETIN

GOLF CAR DATE: 3-17-88 BY: G88-003

REASSEMBLY (Cont'd.)

1. Apply a light coating of high-temperature grease inside the body.
2. Install the new shaft assembly in the solenoid body. Then, install the old insulator and spring over the threaded end of the shaft.
3. Hold the contact plate to prevent the shaft from turning, and screw the new plunger onto the shaft until it reaches the end of the threads. Then, back it off 1/2 ~ 3/4 turns.
4. Clean the contacts on both the shaft assembly and cap.
5. Remove all excess solder from the two coil wires.
6. Make sure the wires are straight (Remember, they are very fragile), and carefully install the guide tubes over them.
7. Install the new end cap and seal over the guide tubes.
8. Remove the guide tubes and discard them. Solder the wires to their terminals.

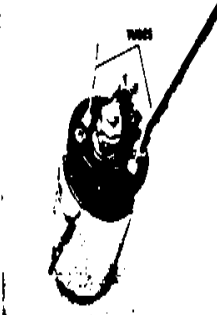

NOTE: Add Job Code 8025 to your G2-A and G2-E Flat Rate Tables. Labor time is 0.5 hour.

PLUNGER ADJUSTMENT

1. Connect a pocket tester (ohms x 1 scale) to the main solenoid terminals as shown. The meter should read ∞.
2. Connect a 12 volt battery (G2-A solenoids) to the small terminals as shown. 36 DC volts must be used for G2-E solenoids.



PAGE 3 OF 4

PLUNGER ADJUSTMENT (Cont'd.)

3. Hold the plunger so it does not turn. Insert a screwdriver into the slot in the shaft, and turn the shaft clockwise until the needle on the tester just starts to move. Then, turn the shaft another 1 ± 1/8 turn clockwise. This will set the plunger so there is about a 1mm overstroke. The ohmmeter should read zero. Disconnect the battery and meter leads.
4. Stake the shaft screw slot by squeezing the collar around it in a vise or with a pair of pliers to prevent the shaft from turning.
5. Install the collar, the plate, the screws, and the rubber cover.
6. Reinstall the solenoid, and check solenoid operation.

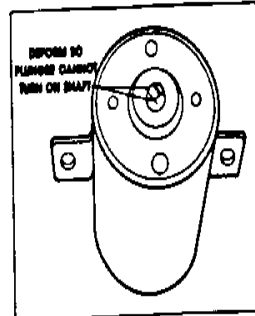

PARTS INFORMATION

- | | |
|--------------------|-----------------------|
| 1. End Cap* | 8. Spring* |
| 2. Seal* | 9. Plate* |
| 3. Shaft Assembly* | 10. Collars* |
| 3A. Shaft Nut | 11. Screws for Plate* |
| 3B. Contact Plate | 12. Rubber Cover* |
| 4. Plunger* | 13. Guide Tubes* |
| 5. Screws for Cap* | |
| 6. Solenoid Body* | |
| 7. Insulator* | |

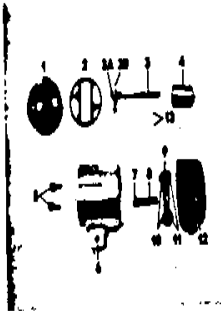

*Part of repair kit.
↳ Reuse these parts.

Part Number	Description	Qty	Dealer Cost
J41-81920-09-00	Solenoid Repair Kit	1	\$24.45
	End Cap	1	Included
	End Cap Seal	1	Included
	Shaft Assembly	1	Included
	Plunger	1	Included
	Guide Tubes	2	Included

WARRANTY INFORMATION

This bulletin is issued for informational purposes only. No special warranty applies.

PAGE 4 OF 4 ROUTE TO: SERVICE PARTS WARRANTY SALES