



TAYLOR-DUNN

Commercial and Industrial Vehicles Since 1949

ARISTOCRAT™ Courtesy Car

SERVICE AND PARTS MANUAL

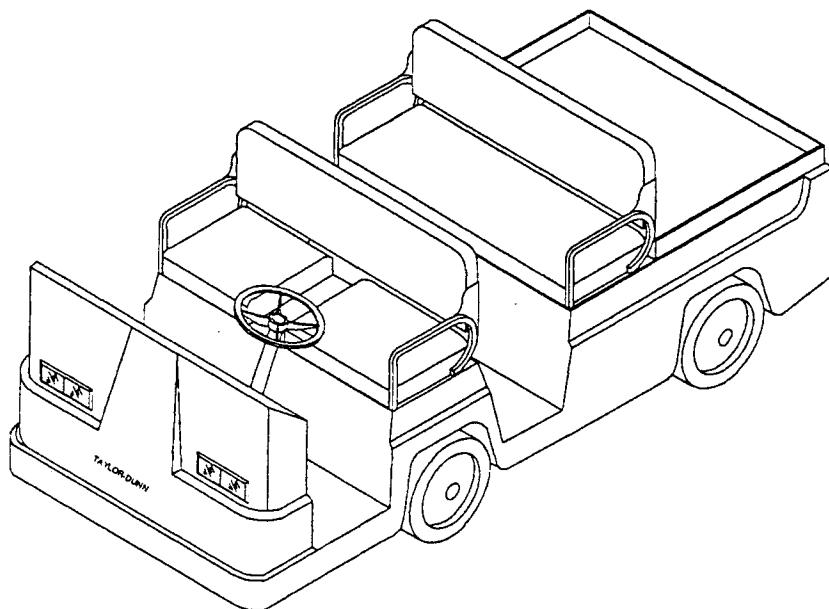

MODEL: ARISTOCRAT™
SERIAL NO.: 97370 & UP
MANUAL NO.: MB-240-00

CONDITIONAL WARRANTY

Taylor-Dunn standard products are warranted for 90 days, parts and labor, unless otherwise stated in the purchase order. Warranties on non-standard products are offered individually.

Products that are under warranty and found to be defective will be repaired or replaced, at Taylor-Dunn's discretion, without charge to the original customer. The original customer will be charged for repair or testing of products that are not under warranty or are not found to be defective when returned under the warranty.

Taylor-Dunn's warranty does not cover misuse or neglect, whether intentional or accidental, due to (but not limited to) any of the following: using incorrect parts; improper installation; improper or unauthorized repair; missing or altered serial numbers; modifications made by the customer; or damage caused by fire, flood or acts of God.

Warranty will be based on dealer's policy at time of sale. All warranty work must be performed by an authorized Taylor-Dunn dealer. It is preferable to obtain warranty service from your original dealer.

It is the vehicle owner's responsibility to maintain and service this vehicle as specified in this manual to ensure warranty coverage.

Be sure to verify the warranty status of this vehicle BEFORE warranty work on this vehicle begins. Any exceptions to the warranty policy must be obtained in writing from Taylor-Dunn Manufacturing Company BEFORE any warranty work begins.

Poor operating habits and improper use of this vehicle can contribute to excessive wear and tear of this vehicle. This may affect your warranty status. When in doubt, consult your authorized Taylor-Dunn dealer.

COPYRIGHT NOTICE

© Taylor-Dunn, 1991. All Rights Reserved. No part of this publication may be reproduced, transmitted, stored in a retrieval system, or translated into any language in any form by any means without the express written permission from Taylor-Dunn.

ARISTOCRAT is a trademark of Taylor-Dunn Manufacturing Company.

TAYLOR-DUNN SERVICE CENTER

You may contact the Taylor-Dunn Service Center directly at:

TAYLOR-DUNN MANUFACTURING COMPANY

2114 West Ball Road

Anaheim, CA 92804-5498

Phone: (714) 956-4040

For Parts: FAX (714) 535-8029

For Service: FAX (714) 956-0504

CONTENTS

SECTION 1: INTRODUCTION	1
ABOUT THIS MANUAL	2
NOTATIONAL CONVENTIONS	3
VEHICLE DESCRIPTION.....	4
SPECIFICATIONS.....	5
VEHICLE OPERATIONAL COMPONENT LOCATION	6
TAKING DELIVERY OF YOUR VEHICLE.....	7
Inspecting the Vehicle	7
Checking the Controls.....	7
What To Do If You Find A Problem.....	8
SECTION 2: VEHICLE OPERATION	9
SAFETY RULES AND GUIDELINES	10
Driving	10
Parking	12
Towing.....	12
VEHICLE CONTROLS	14
DRIVER TRAINING PROGRAM	16
Qualifications Of Driver	16
SECTION 3: SCHEDULED MAINTENANCE	17
INTRODUCTION	18
MAINTENANCE CHECKLIST	19

LUBRICATION CHART	21
TROUBLESHOOTING GUIDE	22
RECOMMENDED SPARE PARTS LIST	24
SPECIAL TOOLS	25
MAINTENANCE PROCEDURES	26
Batteries	26
Charging the Batteries	26
Storing the Batteries	26
Brake Cables	27
Motor Brushes	27
Tires	28
SECTION 4: SERVICE PROCEDURES	29
BRAKE SYSTEM	30
Brake Pedal Linkage	30
Hand Brake Linkage	31
Rear Brakes	32
Adjusting Brakes	32
Replacing the Brake Drum	33
Replacing the Brake Shoes	34
ELECTRICAL SYSTEM	37
FRONT AXLE	40
Adjusting Bearings	41
Aligning Front End	42
Repairing King Pins and Bushings	43
Replacing Ball Joints	45
Replacing Steering Worm	46

REAR AXLE ASSEMBLY	48
Repairing the differential	49
Repairing the rear axle shaft, bearing, and oil seal.....	53
SPEED CONTROL PANEL	55
Accelerator module	56
Battery charger.....	56
Solenoid assembly.....	57
Speed controller	58
Troubleshooting guide.....	59
SECTION 5: ILLUSTRATED PARTS BREAKOUT	65
ACCELERATOR BRAKE PEDAL, HAND BRAKE LINKAGE.....	66
FRONT AXLE	68
FRONT AXLE SUSPENSION.....	70
INSTRUMENT PANEL	72
MOTOR.....	74
REAR AXLE.....	76
REAR AXLE DIFFERENTIAL.....	78
REAR AXLE SUSPENSION	80
REAR BRAKE ASSEMBLY	82
SPEED CONTROL PANEL and CHARGER	84
SOLENOIDS.....	86
STEERING GEAR	88
STEERING GEAR	90
VEHICLE BODY and TRIM	92
VEHICLE COMPONENT LOCATION and OPTIONS	94

LIST OF FIGURES

Figure 1: Adjusting brake pedal and hand brake linkage	31
Figure 2: Adjusting the rear drum brakes	32
Figure 3: Replacing the rear brake shoes	34
Figure 4: Schematic of vehicle electrical system	36
Figure 5: Detailed wiring diagram (sheet 1 of 2)	37
Figure 6: Detailed wiring diagram (sheet 2 of 2)	38
Figure 7: Front axle	39
Figure 8: Adjusting front axle bearings.....	40
Figure 9: Repairing king pins and bushings	42
Figure 10: Replacing ball joints	44
Figure 11: Replacing steering worm.....	45
Figure 12: Rear axle assembly.....	48
Figure 13: Repairing the differential	49
Figure 14: Removal of bearings from the differential	51
Figure 15: Repairing axle shaft, bearing, and oil seal	53
Figure 16: Speed control panel	55
Figure 17: Accelerator module	56
Figure 18: Battery charger.....	56
Figure 19: Solenoid assembly.....	57
Figure 20: Speed controller	58

SECTION 1: INTRODUCTION

ABOUT THIS MANUAL

This manual provides you with information you need to safely operate and maintain this vehicle. We assume that you are a trained vehicle service technician capable of performing routine maintenance procedures such as changing a tire, using a voltmeter, and so forth.

We also assume that you have or will attend a training program designed to familiarize you with the safe operation and use of this particular vehicle.

This manual contains the following major sections:

SECTION 1: INTRODUCTION

—contains information about how to use this manual, a description of the ARISTOCRAT™, how to do an incoming inspection, and vehicle specifications.

SECTION 2: VEHICLE OPERATION

—provides safety rules and guidelines, describes the driver training program, and explains the operation of each control on the ARISTOCRAT™.

SECTION 3: MAINTENANCE PROCEDURE

—contains a scheduled maintenance checklist, lubrication diagram, troubleshooting guide, recommended spare parts list, and detailed maintenance procedures for the ARISTOCRAT™.

SECTION 4: SERVICE PROCEDURES

—contains service procedures, in alphabetical order, for each assembly found in the ARISTOCRAT™. Each major heading contains procedures organized in logical order.

SECTION 5: ILLUSTRATED PARTS

—includes an illustration and parts list for each assembly that has replaceable parts for the ARISTOCRAT™.

NOTATIONAL CONVENTIONS

The following types of notations are used throughout this manual:

WARNING!

A warning alerts you of something that may cause injury to yourself or others. Be sure you exercise special care and follow any instructions provided in a warning message.

Caution!

A caution informs you of something that may cause damage to the vehicle. Be sure you exercise special care and follow any instructions provided in a caution message.

Note: A note provides additional information about a subject.

Tip: A tip is a suggestion that you might find helpful for a specific procedure.

VEHICLE DESCRIPTION

Note: This manual applies to vehicles with serial numbers starting at 97370.

The ARISTOCRAT™ courtesy car is designed to transport people through narrow aisles and over flat, paved concrete or asphalt surfaces. The vehicle provides the type of excellent maneuverability and operational comfort you might expect from courtesy vehicles.

The vehicle can handle a total payload (cargo, passengers and driver) of up to 1200 lbs. Various options are available from the factory or authorized dealer to enable you to customize the vehicle to suit your particular needs (consult your Taylor-Dunn salesperson or representative for current options)

This vehicle conforms to requirements for Type E as described in O.S.H.A. Standard Section 1910.178 (Powered Industrial Trucks) and with all applicable portions of the American National Standard for Personnel and Burden Carriers (ANSI B56.8-1988).

The serial number for this vehicle is imprinted on a decal located on the right rear wheel well located near the 2nd passenger seat.

SPECIFICATIONS

ITEM	SPECIFICATION
Standard Dimensions (Length x Width x Height)	292.1 X 118.7 X 114.3 cm
	115" X 46¾" X 45"
Standard Dry Weight	575 kg (1264 lbs)
Standard Turning Radius	335.3 cm (132")
Batteries	Six 220 AH, 6 volts (107 minute rating)
Charger	Built-in, automatic, 36 volt, 25 amp
Draw bar pull	68 kg (150 lbs) normal
	204 kg (450 lbs) ultimate
Speed Controller	Stepless solid state controller
Tires	18 x 8.50 pneumatic terra tire (front and rear)
Motor	Rated 36 volt, 6 hp (4.5kW) @ 1400 intermittent duty, 2 hp (1.5kW) @ 2800 rpm normal duty.
Max Loading Limit	546 kg (1200 lbs)
Brakes	Rear drum brakes
	Parking brake with hand-release lever
Max number of passengers	6 (driver and passengers). W/optional 3rd. seat

VEHICLE OPERATIONAL COMPONENT LOCATION

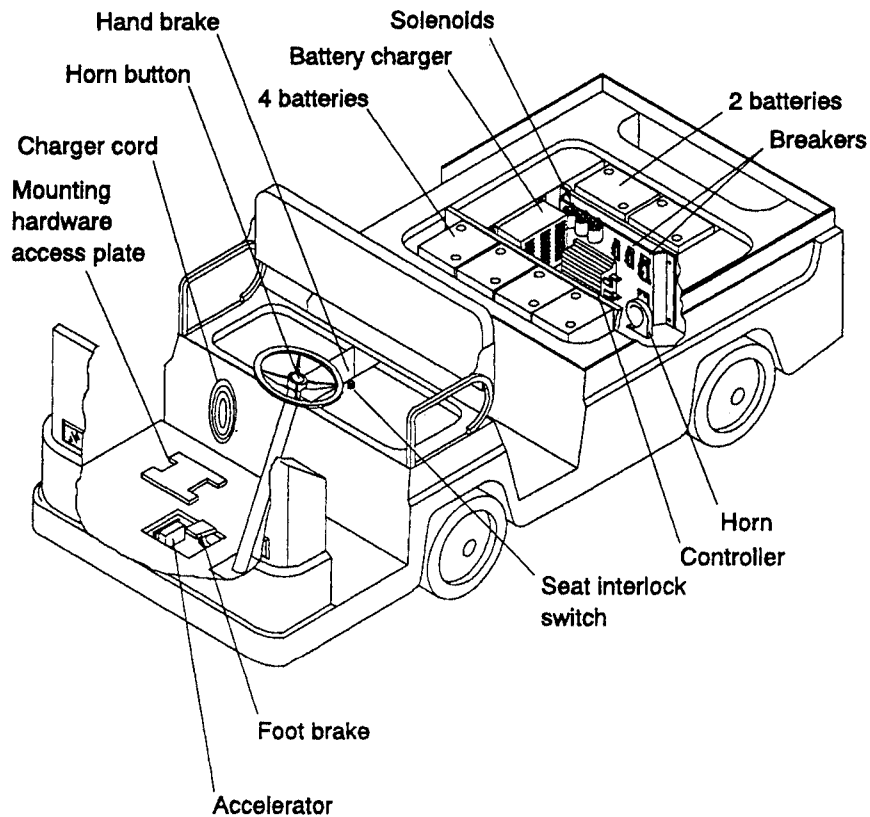
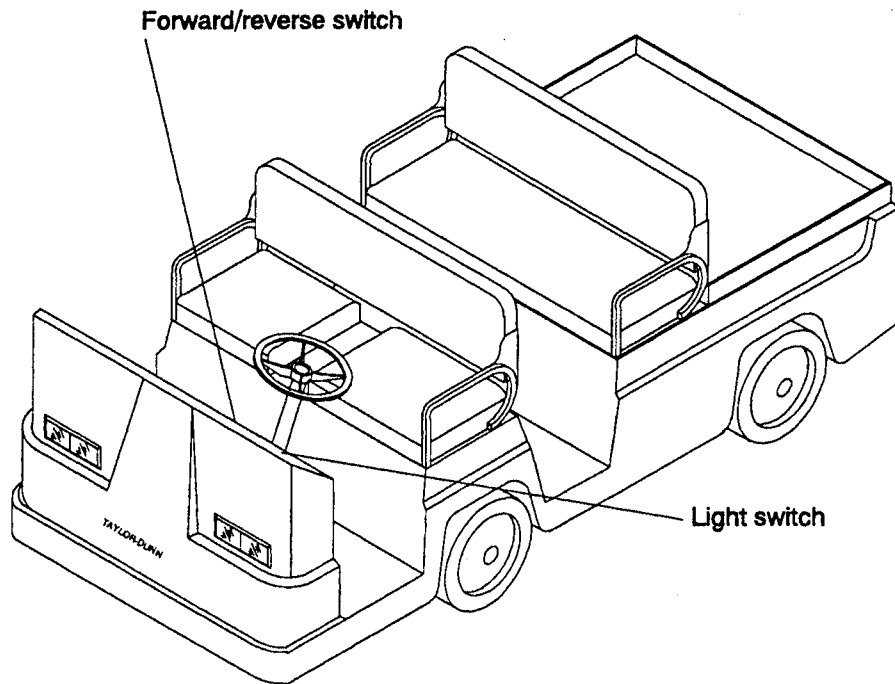

TAKING DELIVERY OF YOUR VEHICLE

Before you sign the carrier's delivery receipt for this vehicle, use the following guidelines to make sure there are no obvious problems.

Inspecting the Vehicle

Note: *To gain access to the control area on the vehicle, remove the 2nd passenger seat, slide the rear deckboard forward and remove.*

- Examine the contents of all packages and accessories that may have come in separate packages with this vehicle. Make sure everything listed on the packing slip is there. Nothing should look broken or damaged.
- Examine any visible wiring for obvious signs of damage. Check that all connections are secure.
- Check that the battery connections are tight and all cells are filled.
- Inspect the tires for obvious wear or damage. Check the tire pressure. Make sure that all wheel lugs are secure.
- Check the body, seats, windshield (optional), trim and other external parts for obvious damage.

Checking the Controls

Try each of the following controls before turning on the keyswitch:

- accelerator pedal
- brake pedal
- forward - reverse switch
- parking brake
- steering wheel
- horn
- lights

Each control should move smoothly and easily, without sticking or requiring undue effort.

Approving Delivery

Place a check mark next to each item that is true:

- visual inspection OK
- all controls work properly
- vehicle runs smoothly
- no other problems found

If all items have been checked, you may sign the delivery receipt and proceed to the next section. If not, read What To Do If You Find A Problem .

What To Do If You Find A Problem

If you find a problem with this vehicle, you must describe the problem on the carrier's delivery receipt to qualify for warranty repair of those items (see Warranty at front of manual).

Note: *If you discover a problem after you sign the delivery receipt, you must file a written report describing the problem to the carrier who delivered this vehicle. This report must be filed within 48 hours from*

SECTION 2: VEHICLE OPERATION

SAFETY RULES AND GUIDELINES

Note: *It is the responsibility of the owner of this vehicle to ensure that the operator understands the various controls and operating characteristics of this vehicle, and obeys the following safety rules and guidelines (extracted from the American National Standards Institute, Personnel and Burden Carriers — ANSI B56.8).*

Driving

This vehicle is designed to be driven in and around places with flat paved access ways such as hotels, parks, resorts, nurseries and warehouses. Before you drive this vehicle, please observe the following safety rules and guidelines.

WARNING!

Speeds in excess of 12 MPH will cause steering and brake difficulty and eventually loss of control.

WARNING!

Do not drive this vehicle on public roads and highways. This vehicle is designed to attain speeds up to 12 MPH. Always drive at a safe speed posted within your specific facility, normally below 5 MPH. This vehicle will exceed the designed speed of 12 MPH when driven on a down grade.

- ❑ do not drive this vehicle unless you are a qualified operator
- ❑ do not start or move this vehicle unless all occupants are seated
- ❑ keep all body parts (head, arms, legs) inside this vehicle while it is moving
- ❑ drive slowly when making a turn, especially if the ground is wet, slippery, or when driving on an incline

WARNING!

This vehicle will overturn easily if turned sharply when driving, especially when on an incline or when carrying a heavy load.

- ❑ drive only on level surfaces or on surfaces having an incline of no more than 10%
- ❑ do not drive over loose objects, holes or bumps
- ❑ observe all traffic regulations and speed limits
- ❑ keep to the right under normal conditions
- ❑ maintain a safe distance from all objects
- ❑ keep the vehicle under control at all times
- ❑ yield right of way to pedestrians, ambulances, fire trucks or other vehicles in emergency situations
- ❑ do not overtake another vehicle at intersections, blind spots or other dangerous locations
- ❑ keep a clear view ahead at all times
- ❑ slow down and sound the horn when approaching a corner or other blind intersection
- ❑ avoid dangerous activities such as stunt driving or horseplay
- ❑ do not drive with more than the maximum number of passengers allowed for this vehicle
- ❑ do not drive this vehicle in hazardous areas unless this vehicle is approved for such operation
- ❑ immediately report any accident or vehicle problem to your supervisor

Loading and Unloading

- ❑ do not load cargo that can easily fall off this vehicle
- ❑ do not exceed the cargo load capacity of this vehicle
- ❑ do not carry more than the maximum number of passengers allowed for this vehicle
- ❑ be extra careful when handling cargo that is longer, wider or higher than this vehicle

Parking

- ❑ set hand brake before leaving vehicle
- ❑ if you will be away from this vehicle, put the forward/reverse switch in the off position, set the hand brake, turn off the keyswitch and remove the key
- ❑ do not park this vehicle on an incline
- ❑ do not block fire aisles, fire equipment or stairways

Towing

- ❑ to tow this vehicle, attach a tow strap to the front bumper tow bar and place the forward/reverse switch in the off position.
- ❑ use another driver to steer this vehicle while it is towed; be sure the driver uses the brakes when you slow or stop the towing vehicle.

WARNING!

Do not exceed 5 MPH or carry any passengers while towing this vehicle.

VEHICLE CONTROLS

The following describes the use of each control on this vehicle.

Note: *Some controls are optional equipment and may not be installed on this vehicle.*

Accelerator pedal

The accelerator pedal, located to the right of the brake pedal, controls the speed of the vehicle and is designed for right foot operation only. It operates the same as the accelerator pedal in an automobile.

Backup warning alarm (optional)

A warning alarm sounds whenever the vehicle is in reverse, keyswitch is on, and the accelerator is depressed.

Forward - Reverse Switch

The forward - reverse switch, located on the right side of the instrument panel determines the direction of travel (forward or reverse) of the vehicle. It is a rocker type switch. Depress the upper part of the switch to go forward. Depress the lower part of the switch to go in reverse.

Power Cutoff Seat Interlock

The power cutoff seat interlock, located under the drivers seat, is designed to allow operation of the vehicle only when the driver is seated.

Foot brake pedal

The foot brake pedal, located to the right of the steering column, is for operation with the right foot only. It works the same as the brake in an automobile. Applying pressure to the brake pedal slows the vehicle according to the amount of pressure you apply. Removing your foot from the pedal releases the braking action.

Hand brake lever

The hand brake lever is located between the driver and passenger seats. To set the hand brake, pull up on the lever. Push the button on the end of the lever to release the hand brake and push down.

Tip: For easier application of the hand brake, depress the foot brake pedal while applying the hand brake.

Headlight switch

A headlight switch, located on the instrument panel, turns the headlight and taillights on or off. It is a rocker type switch. To turn the lights on, push the upper half of the switch. To turn the lights off, push the lower half of the switch.

Horn button

The horn button, located on the steering wheel, operates like the horn on a standard automobile. Depress the button to sound the horn, and release the button to stop.

Keyswitch

A keyswitch, located on the right side of the steering column, is designed to secure the vehicle in the OFF position. You cannot remove the key when the keyswitch is in the ON position. Rotate the key clockwise to turn the vehicle on, counterclockwise to turn the vehicle off.

Steering

The steering system is similar to standard automobiles. To turn right, turn the steering wheel clockwise. To turn left, turn the steering wheel counterclockwise.

DRIVER TRAINING PROGRAM

The owner of this vehicle shall conduct an Operator Training program for all those who will be operating this vehicle. The training program shall not be condensed for those claiming to have previous vehicle operation experience. Successful completion of the Operator Training program shall be required for all personnel who operate this vehicle.

The Operator Training program shall include the following:

- ◆ operation of this vehicle under circumstances normally associated with your particular environment
- ◆ emphasis on the safety of all passengers, cargo and personnel
- ◆ all safety rules contained within this manual
- ◆ proper operation of all vehicle controls
- ◆ a vehicle operation and driving test

Qualifications Of Driver

Only those who have successfully completed the Operator Training program are authorized to drive this vehicle. Operators must possess the visual, auditory, physical and mental ability to safely operate this vehicle as specified in the American National Standards Institute, Personnel and Burden Carriers — ANSI B56.8.

The following are the minimum requirements necessary to qualify as an Operator of this vehicle:

- ◆ demonstrate a working knowledge of each control
- ◆ understand all safety rules and guidelines as presented in this manual. Know how to properly load and unload cargo and passengers
- ◆ know how to properly park this vehicle
- ◆ recognized an improperly maintained vehicle
- ◆ demonstrate ability to handle this vehicle in all normal and safe conditions

SECTION 3: SCHEDULED MAINTENANCE

**This page
intentionally left
blank**

INTRODUCTION

This section explains how to perform the scheduled maintenance procedures. Use the Maintenance Checklist to determine how often you should perform each procedure.

This section contains the following:

- maintenance checklist
- lubrication chart
- troubleshooting guide
- recommended spare parts list
- detailed maintenance procedures

MAINTENANCE CHECKLIST

PERIODIC MAINTENANCE CHECKLIST					
Maintenance Item	Weekly (30 hrs)	Monthly (120 hrs)	Quarterly (360 hrs)	Semi- yearly (720 hrs)	Yearly (1440hrs)
*Check and adjust brake system .	-	✓	-	-	-
*Check and lubricate front wheel bearings (2 zerk fittings)	-	-	-	✓	-
*Check brake lining for wear.	-	-	✓	-	-
*Check and adjust front bearings.	-	-	✓	-	-
*Lubricate steering gear box.	-	-	-	✓	-
Check and fill batteries (use distilled water only).	✓	-	-	-	-
Wash batteries with water (use soda if necessary)	-	-	✓	-	-
Check motor brushes	-	-	-	-	✓
*Check tire pressure	✓	-	-	-	-
*Check front end alignment	-	-	✓	-	-
Lubricate all zerk fittings.	-	✓	-	-	-
Lubricate all moving parts without zerk fittings (use all-purpose oil).	-	-	✓	-	-
Clean and tighten all wire connections.	-	-	✓	-	-
Check rear axle differential .	-	-	-	✓	-
Drain rear axle differential ; refill with SAE 30 oil. (DO NOT USE HYPOID 90W)	-	-	✓	-	-
Clean and repack front wheel bearings (use wheel bearing grease)	-	-	-	✓	-
NOTE: Items with an asterisk (*) are related to safety.					

LUBRICATION CHART

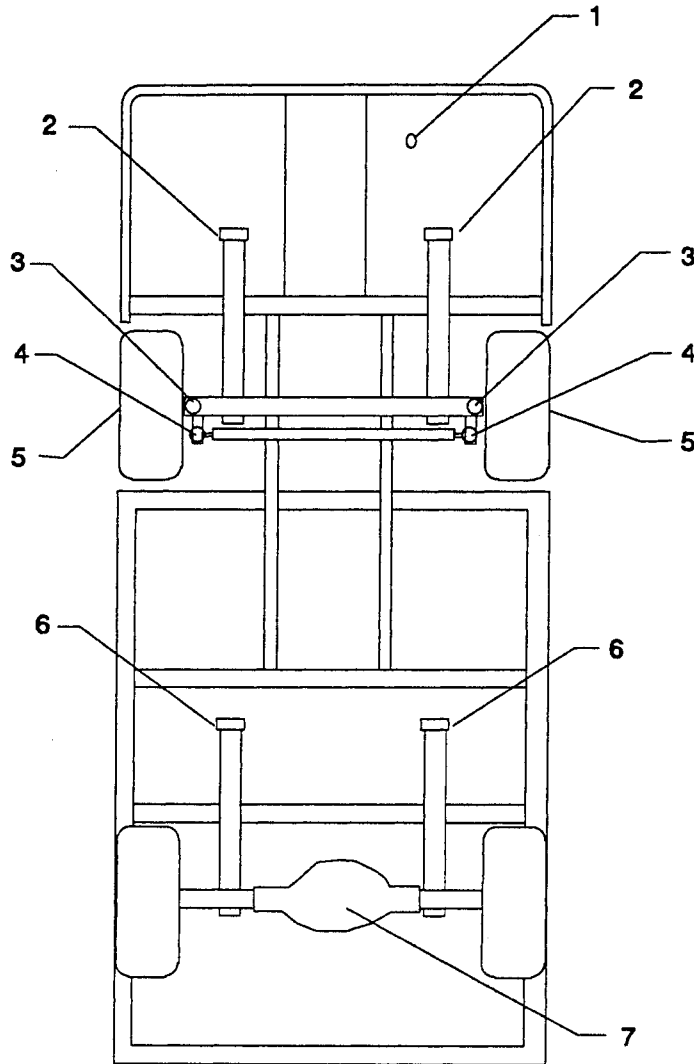

- Item #1 - Steering gear
- Item #2 - Front leaf springs
- Item #3 - Front axle
- Item #4 - Front ball joints
- Item #5 - Front axle bearings
- Item #6 - Rear leaf springs
- Item #7 - Rear axle differential

Items 1 thru 6 use super lithium grease

Item 7 use SAE 30 oil

TROUBLESHOOTING GUIDE

SYMPTOM	PROBABLE CAUSE	CORRECTIVE ACTION
Steering pulls in one direction	Loose wheel bearing	Adjust wheel bearing
	Low tire pressure	Fill tires to 30 or 50 psi
	Loose front axle mounting	Tighten mounting bolts
Hard to steer	Loose wheel bearing	Adjust wheel bearing
	Low tire pressure	Fill tires to 30 or 50 psi
	Worn ball joints	Replace ball joints
	Unlubricated ball joints	Lubricate ball joints
	Worn king pin bushings	Replace king pin bushings
	Unlubricated king pin bushings	Lubricate king pin bushings
Brakes feel soft	Check for worn lining	Adjust brake shoes; replace shoes if lining is less than 0.039" thick
	Alignment of brake shoes	Realign brake shoes
	Oil on brake shoe lining	Find oil source and correct, or replace brake shoes
	Dirt on brake shoe lining	Clean brake shoe lining
	Bind in linkage	Loosen or realign brake linkage
	Weak pedal return spring	Replace pedal return spring
No brakes	Broken shoes	Replace brake shoes
	Broken connection in linkage	Replace linkage

TROUBLESHOOTING GUIDE

Lack of power or slow operation	Dragging brake	Re-adjust brakes
	Tight front wheel bearing	Re-adjust wheel bearing
	Defective rear axle bearing	Replace bearings
	Bind or drag on differential	Repair differential
	Corroded battery connections	Clean or replace
	Defective or worn motor brushes	Clean or replace
	Loose wire connections	Check wires and connections
	No continuity through motor	Repair or replace motor
Motor does not run	Motor or solenoids	Check motor and solenoids
	Dead battery	Replace or recharge battery
	Loose wire connections	Check wires and connections
Controller does not operate	Loose wire connections	Check wires and connections
	No accelerator output	Replace accelerator
	Defective seat switch	Replace seat switch
	Defective keyswitch	Replace keyswitch
	Low battery voltage	Charge battery
Thump or grinding noise in drive axle	Motor bearing	Replace motor bearing
	Loose motor on base	Tighten and adjust motor
	Defective gears in differential	Replace gears
	Defective bearing in differential	Replace bearing

RECOMMENDED SPARE PARTS

PART #	DESCRIPTION	QTY.
13-746-10	Tire and Wheel Assembly, 18 x 8.50	4
62-033-00	Accelerator Module	1
62-204-00	Speed Controller	1
71-039-00	Forward/Reverse Switch	1
71-111-00	Brake Light Switch	1
71-120-00	Keyswitch	1
71-102-15	Switch, Push Button w/Seal	2
72-501-36	Solenoid, SPST, 36 volt, 100 amp	1
72-501-37	Solenoid, SPDT, 36 volt, 100 amp	2
73-004-20	Horn, 12 volt	1
75-149-27	Power Pac Harness	1
80-017-00	Tapered Bearing, 1"	4
80-410-20	Flange Bearing, .750"	2
85-250-00	Spring, 1.0625" x 3.625"	1
96-818-10	Cable Assembly, 17-14.125"	1
96-826-12	Park Brake Cable Assembly	2
98-200-00	Brake Pedal Pad, Rubber	1
98-254-00	Accelerator Pedal, Aluminum	1
NOTE: The quantity indicated is per vehicle		

SPECIAL TOOLS

MAINTENANCE PROCEDURE	USE THIS TOOL:	TO DO THIS:
Chassis Service	Cable Injector	to lubricate cables
	Dial Gauge	measure small movement or runout
Electrical Service	Multimeter	check electrical system
	Hydrometer	measure the specific gravity of the battery electrolyte
	Ohmmeter	check continuity of electrical wiring
	Accelerator Module Test Box (62-027-30)	check accelerator and connections
	Test Light (62-027-00)	check controller output
	High Current Ammeter	check motor current

MAINTENANCE PROCEDURES

Batteries

The batteries located under the 2nd passenger seat and deck area should be checked for proper electrolyte level and cleaned to maintain optimum charge. Do not allow the electrolyte level to get low or the battery to remain dirty.

Note: *In order to gain access to the batteries you must remove the 2nd passenger seat, slide the deckboard forward and remove deckboard.*

- 1** Check the electrolyte level, fill with distilled water up to the correct level.
- 2** Clean the batteries with water. Thoroughly dry the battery surface using dry rags.

Caution

Do not overfill the batteries. If the top of the batteries appears wet before you fill or wash it, it is probably due to leaky or loose cell covers. Tighten or replace covers.

- 3** Clean the cell posts, connectors and steel tray with water.

Caution

While cleaning the batteries make certain to keep solenoids, controller and battery charger from getting wet or damp.

Charging The Batteries

Caution

Do not use a high amperage boost charger.

Caution

Do not reverse polarity of the battery cables.

Storing The Batteries

Always charge the batteries before storing for long periods and recharge every two months.

If the climate is very hot, store the batteries in a cool place to extend the shelf life of the battery. Storing the batteries during long periods of inactivity or during cold months can cause the battery plates to erode and lose their charge.

Brake Cables

Visually inspect the brake cables for signs of wear or cracks.

Visually inspect the end connections for broken wire strands.

Caution!

Replace any worn or damaged cables immediately.

Motor Brushes

There are two procedures for checking the motor brushes depending upon the type of motor in the vehicle. The average lifespan of the motor brushes is approximately 300 hours.

WARNING!

If the brushes are worn and not replaced, damage to the armature will result.

If your motor has two small holes in the terminal end of the stator shell, do the following to check the brushes:

- 1** Insert a 1/16" diameter drill rod or paper clip into the measurement holes.
- 2** Measure the distance the drill rod or paper clip goes into the hole. When the brushes are new the rod will measure about 3/4". If the rod measures 1 1/2" or more the brushes need to be replaced.

Procedures continue on next page.

To check the brushes for wear if no motor brush measurement holes are on the motor, do the following:

- 1** Disconnect main power from batteries.
- 2** Disconnect motor wires.

Note: *Make sure you note the position of the wires on the motor before disconnecting.*

- 3** Remove motor from rear differential. Disassemble motor. Remove motor bolts, backing plate and brush holder.
- 4** Inspect and measure the motor brushes. If the brushes measure 3/4" or less on the long side they will need to be replaced.
- 5** To reinstall motor reverse procedures 1 thru 4.

Tires

To replace the tires, do the following:

- 1** Check the tires for nicks or grooves and replace if necessary
- 2** Ensure that the tire is properly seated on the rim.
- 3** Ensure that all the lug nuts are installed and tight.
- 4** If the tires are 8.50 x 8, check for proper inflation (30 psi).

SECTION 4: SERVICE PROCEDURES

BRAKE SYSTEM

The brake system consists of:

- ▣ brake cables
- ▣ brake pedal linkage
- ▣ hand brake linkage
- ▣ rear brakes

Caution!

Do not drive the vehicle if any worn or broken part is detected in any part of the brake system. The cause of the damage must be repaired immediately.

IF:	TRY THIS:
Brakes feel spongy	<ul style="list-style-type: none"> • adjust brake cable assembly • adjust or replace brake shoes • replace brake drums
Brake pedal feels low	<ul style="list-style-type: none"> • adjust brake cable assembly • adjust or replace brake shoes • replace brake drums
Brake pedal feels hard	<ul style="list-style-type: none"> • adjust brake cable assembly • adjust or replace brake shoes • clean and lubricate brake ledges
Brakes are dragging	<ul style="list-style-type: none"> • adjust brake cable assembly • adjust or replace brake shoes • replace return spring • free up and lubricate cables and linkage • adjust or replace wheel bearings
Brakes are grabbing or pulling	<ul style="list-style-type: none"> • adjust or replace brake shoes • tighten or replace return spring • replace brake drum • adjust wheel bearings

Brake Pedal Linkage

To adjust the brake pedal linkage, do the following (see Figure 1):

Note: You must adjust the rear brakes before you adjust the brake pedal linkage.

- 1** Loosen the two jam nuts on the brake cable assembly until loose.

Tip: The brake pedal cable assembly is located under and between the front seats.

- 2** Turn the brake cable assembly until the brake cables are slightly tight.

Note: There should be some slack on the brake cables after adjusting.

- 3** Tighten the two jam nuts to the clevis.

Note: The brake pedal should have about 1/2" of play before applying the brakes.

Hand Brake Linkage

To adjust the hand brake linkage, do the following (see Figure 1):

Note: You must adjust the rear brakes before you adjust the hand brake.

- 1** Place the hand brake in the off position (all the way down).
- 2** Loosen the jam nut on the clevis.
- 3** Remove the cotter pin and clevis pin from the clevis.
- 4** Turn the clevis until the linkage is snug when the clevis pin is installed back on the clevis. Install cotter pin into clevis pin.

- 5** Tighten the jam nut onto the clevis. Make sure the rear wheels rotate freely.

Note: The clevis, which attaches to the bottom of the hand brake, is located under and between the front seats.

Caution!

Always use a new cotter pin. Use a new clevis pin if any wear is evident.

- 6** Pull up on the brake handle until it stops. Verify that the wheels are in a locked position.

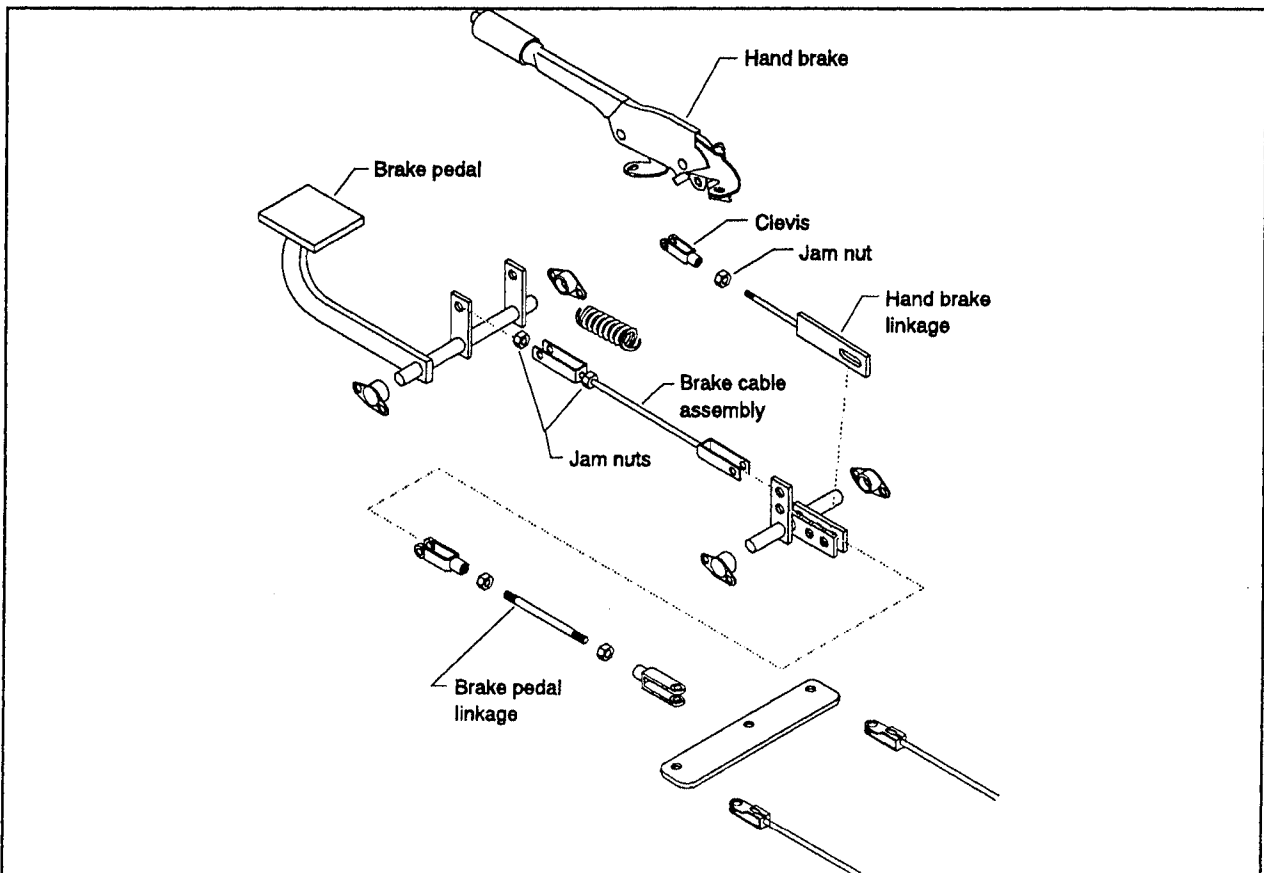

Figure 1 Adjusting brake pedal and hand brake linkage

Rear Brakes

The rear brakes are mechanical drum brakes. They are manual adjust and will require periodic adjustment to assure safe operation and maximum brake life.

Servicing the rear brake assembly consists of:

- adjusting brakes
- replacing brake drum
- replacing brake shoes

Adjusting Brakes

To adjust the rear drum brakes, do the following (see Figure 2):

- 1** Raise the vehicle and support it.

WARNING!

Always use jack stands when raising and supporting the vehicle for inspection or repair.

- 2** Remove the wheel and tire assembly.
- 3** Insert a brake adjusting spoon into the adjusting slot in the brake drum and engage the lowest possible tooth on the starwheel.

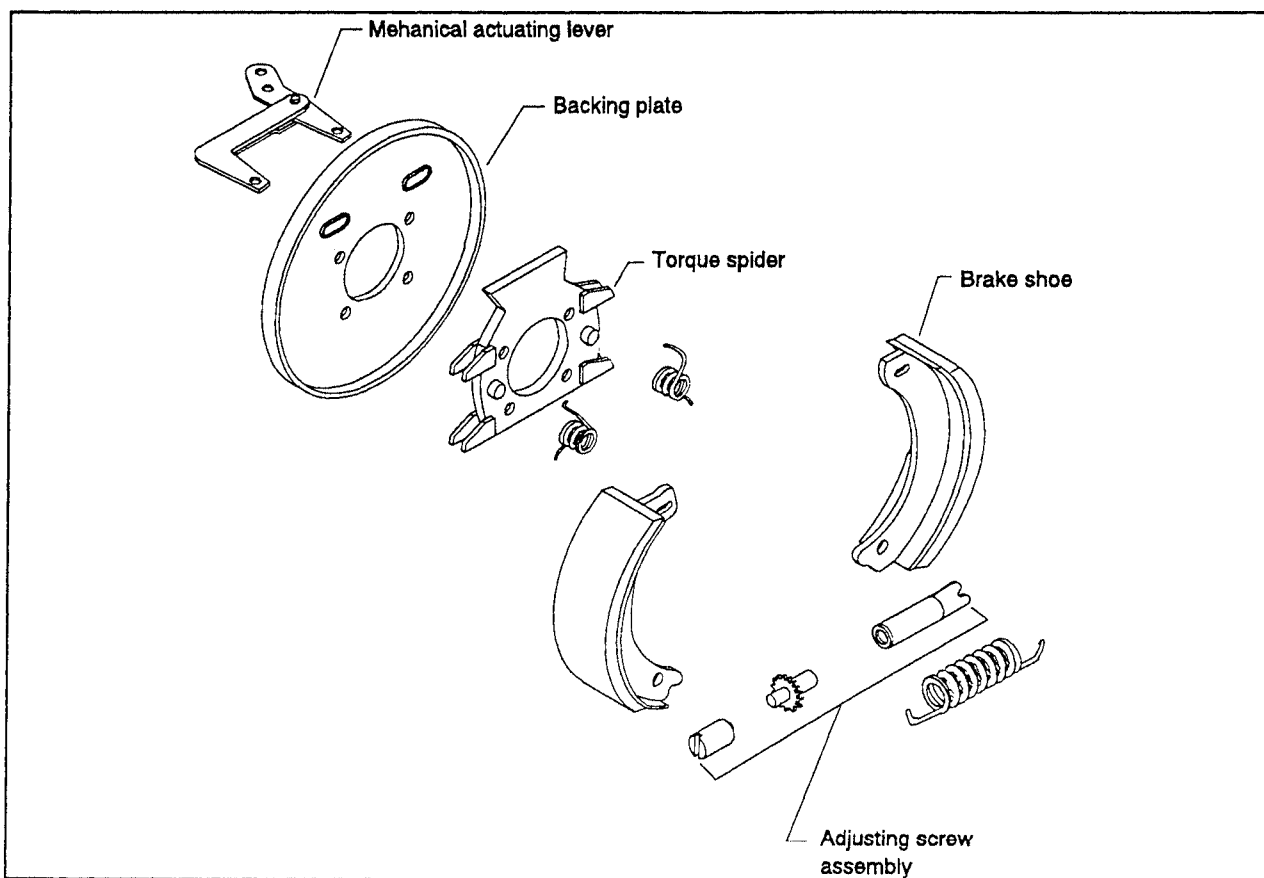

Figure 2 Adjusting the rear drum brakes

- 4** Move the end of the brake spoon downward (moves the starwheel up) and expand the adjusting screw until the brakes lock the wheel.
- 5** Engage the topmost tooth on the starwheel with the brake adjusting spoon.
- 6** Move the end of the adjusting spoon upward (moves the adjusting screw starwheel downward) and contact the adjusting screw.
- 7** Back off the adjusting screw starwheel until the wheel spins freely with a minimum of drag.

Note: *Keep track of the number of strokes taken with the brake adjusting spoon.*

- 8** Repeat steps 3 to 8 for the other side.

Note: *The starwheel adjuster must be backed off the same number of strokes as the first side to prevent side to side brake pull.*

- 9** Lower the vehicle.
- 10** Test drive the vehicle.

Note: *If the front of the vehicle pulls to the right when braking, adjust (back off) the right brake assembly. If the vehicle pulls to the left, adjust (back off) the left brake assembly.*

Replacing the Brake Drum

To replace the rear brake drum, do the following:

- 1** Raise the vehicle until the tires clear the floor and install jack stands.

WARNING!

Always use jack stands when raising and supporting the vehicle for inspection or repair.

- 2** Remove the wheel and tire assembly.
- 3** Remove the holding washer from the wheel stud.
- 4** Remove the brake drum.

Note: *If the drum is grooved or worn, it may be necessary to back off the brake shoe adjustment before removing the brake drum. The brake shoes may need to be replaced if grooved or show uneven wear.*

- 5** Remove any protective coating from the new brake drum using carburetor degreaser or other solvent.
- 6** Install the new brake drum.
- 7** Adjust the brakes.
- 8** Replace the wheel and tire assembly.
- 9** Remove the jackstands and lower the vehicle.
- 10** Test drive the vehicle.

Replacing the Brake Shoes

To replace the rear brake shoes, do the following (see Figure 3).

- 1 Raise the vehicle until the tires clear the floor and install jack stands.

WARNING!

Always use jack stands when raising and supporting the vehicle for inspection or repair.

- 2 Remove the wheel and tire assembly.
- 3 Remove the brake drum.

- 4 Remove the brake shoe retracting spring.

- 5 Remove the hair pins from the mechanical actuating lever.

NOTE: Make sure you note the position of the mechanical actuating lever when removing it from brake assembly.

- 6 Remove the brake shoe holddown spring from each shoe.

- 7 Remove the brake shoes and adjusting screw assembly.

NOTE: Make sure you note the position of the adjusting screw assembly when removing from brake assembly.

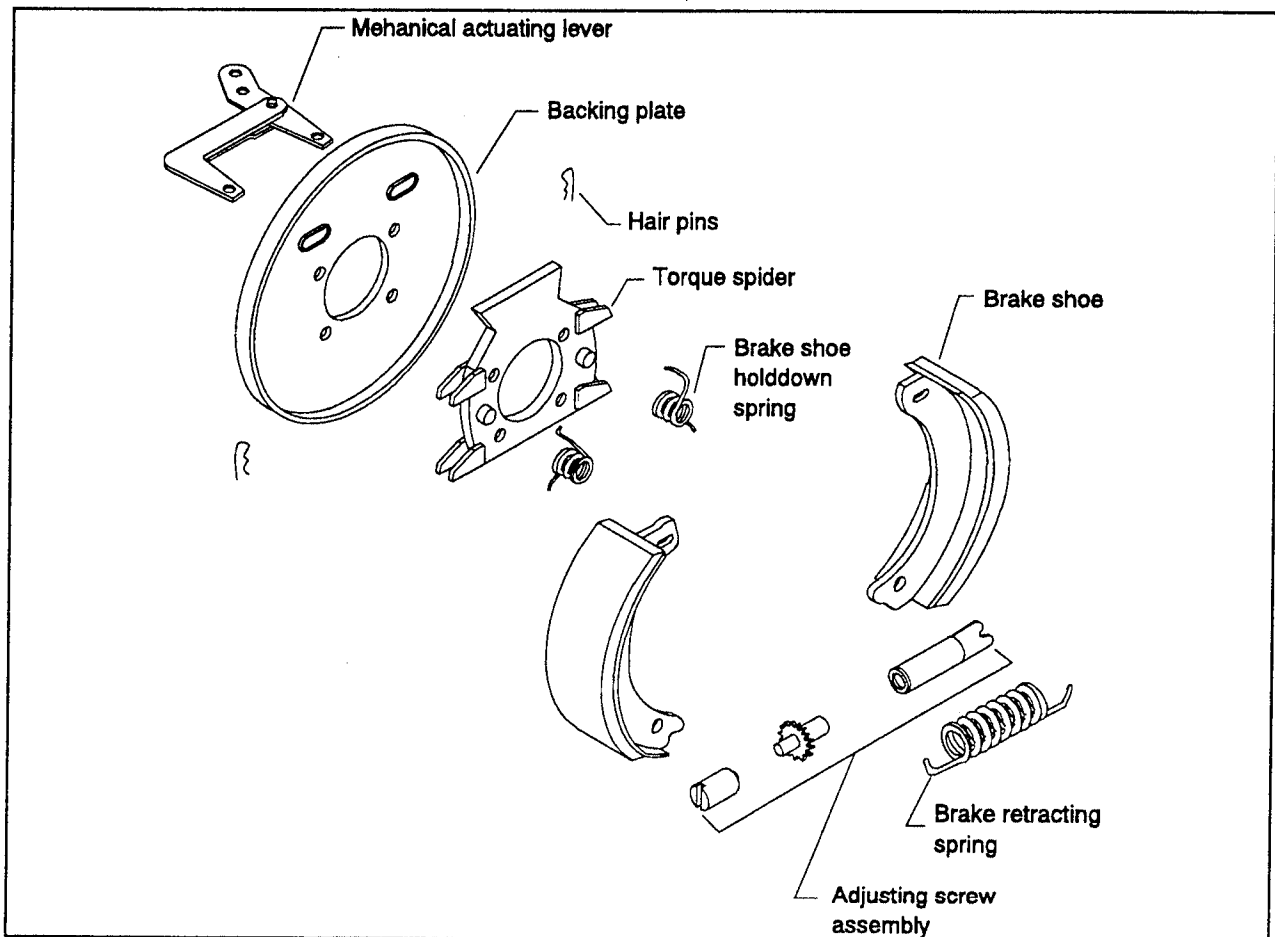

Figure 3 Replacing the rear brake shoes

- 8** Disassemble and clean the adjusting screw assembly.
 - 9** Apply Hi-Temp grease to the adjusting screw assembly, the holddown and retracting spring contacts on the brake shoes and the torque spider contact points on the brake shoes.
 - 10** Install the brake shoes on the torque spider.
 - 11** Install the adjusting screw assembly.
 - 12** Install the brake shoe retracting spring.
 - 13** Install the brake shoe holddown springs.
 - 14** Assemble the backing plate and mechanical actuating lever.
 - 15** Connect the hair pins to the mechanical actuating lever.
- NOTE:** *Be sure to install each adjusting screw and mechanical actuating lever on the correct side of the vehicle.*
- 16** Adjust the brakes after installing the brake drums.
 - 17** Install the wheels.
 - 18** Lower and road test the vehicle.
- Note:** *New brakes may pull to one side or the other before they are seated. If the brakes continue to pull or braking seems erratic, readjust the brakes.*

**This page
intentionally left
blank**

ELECTRICAL SYSTEM

The vehicle's electrical system consists of the following:

- accelerator module (Section 4)
- battery (Section 3)
- electrical wiring (Section 4)
- horn (Section 5)
- instrument panel (Section 5)
- speed controller (Section 4)
- motor and solenoids (Section 4)

Service procedures for each item can be found as indicated.

WARNING!

Disconnect the main battery leads and remove the key before working on any part of the vehicle's electrical system.

Figure 4 shows an overall view of the vehicle's electrical system. Figure's 5 to 6 are detailed wiring diagrams. (including options).

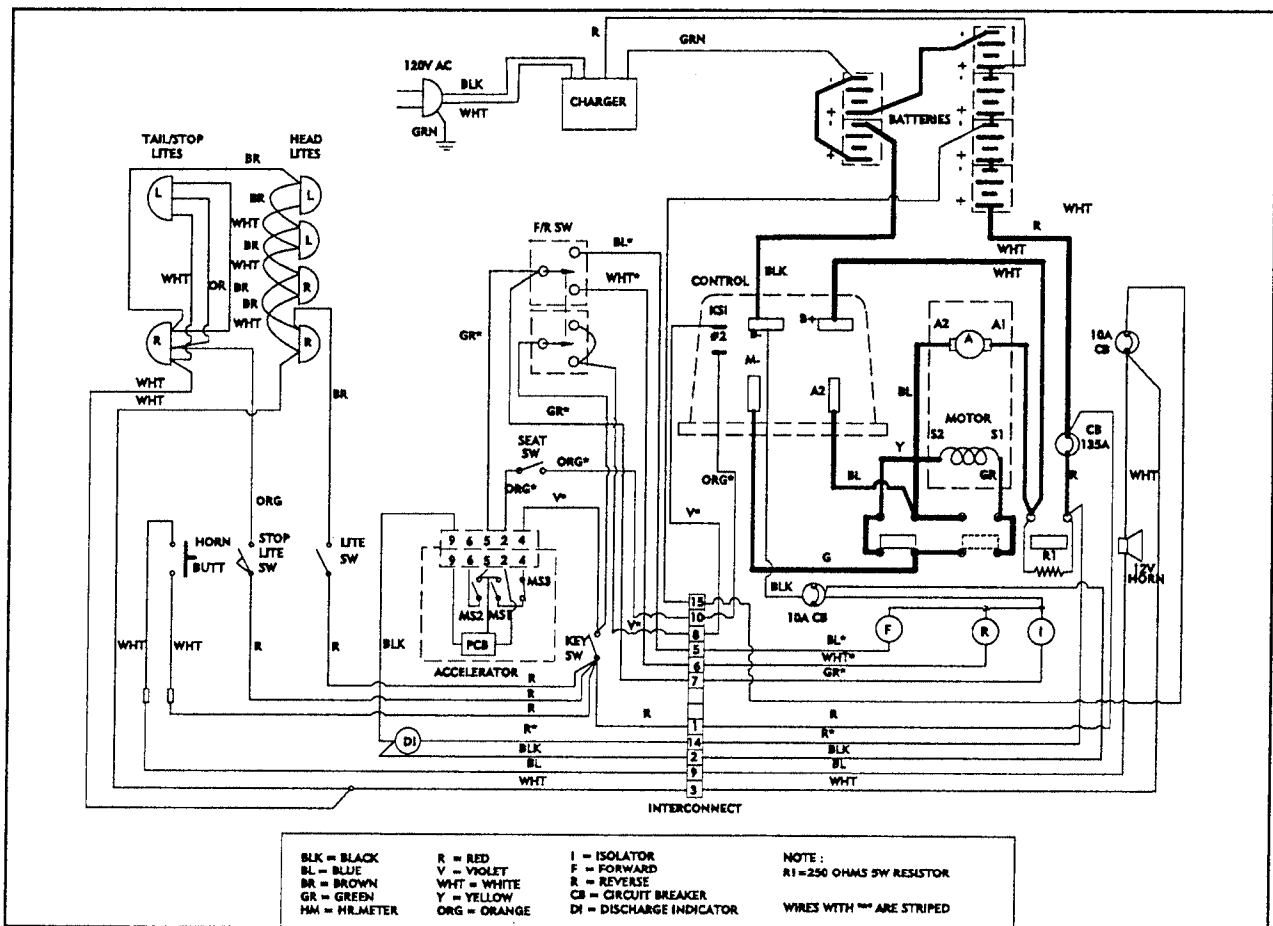

Figure 4 Schematic of vehicle electrical system

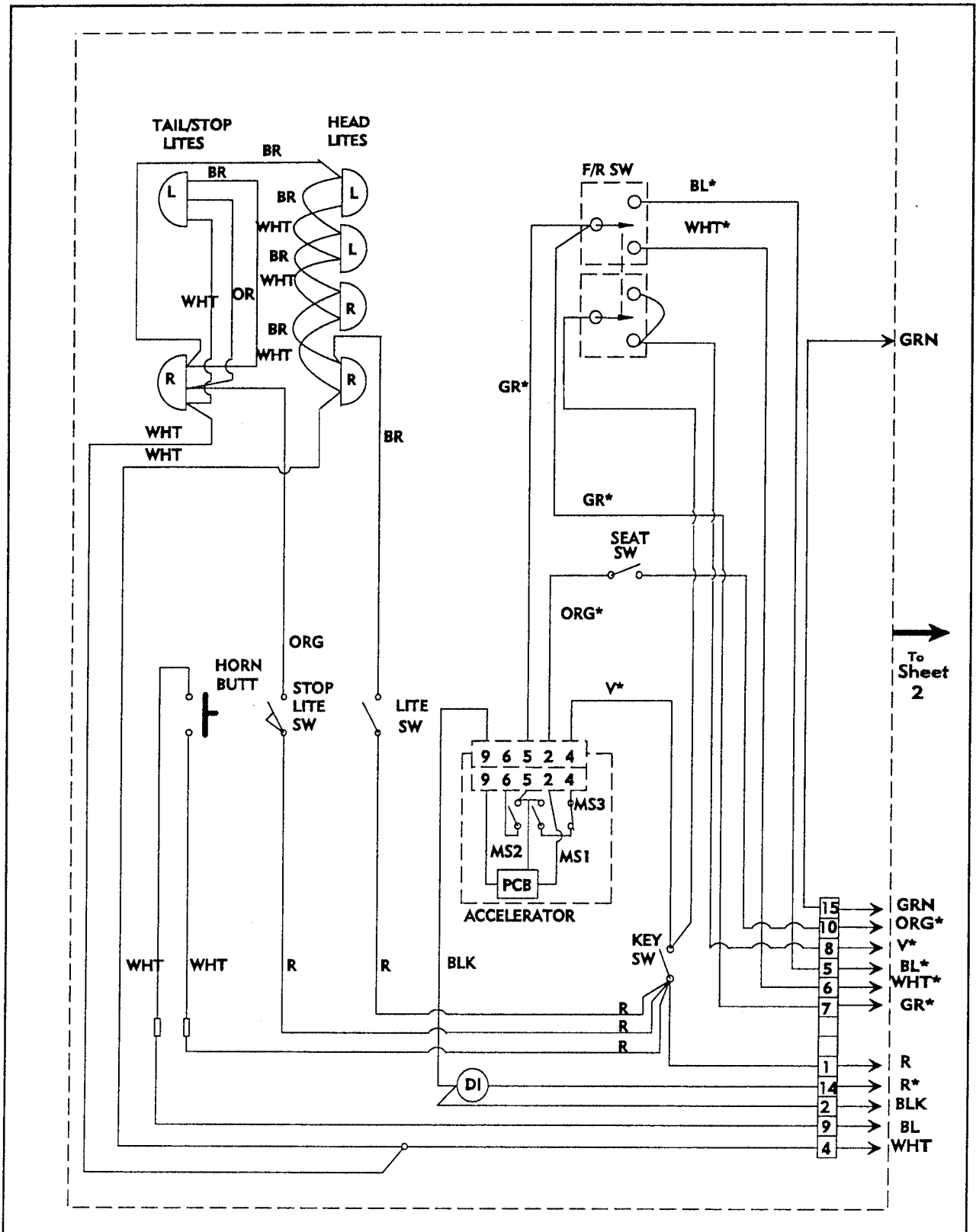

Figure 5 Detailed wiring diagram (sheet 1 of 2)

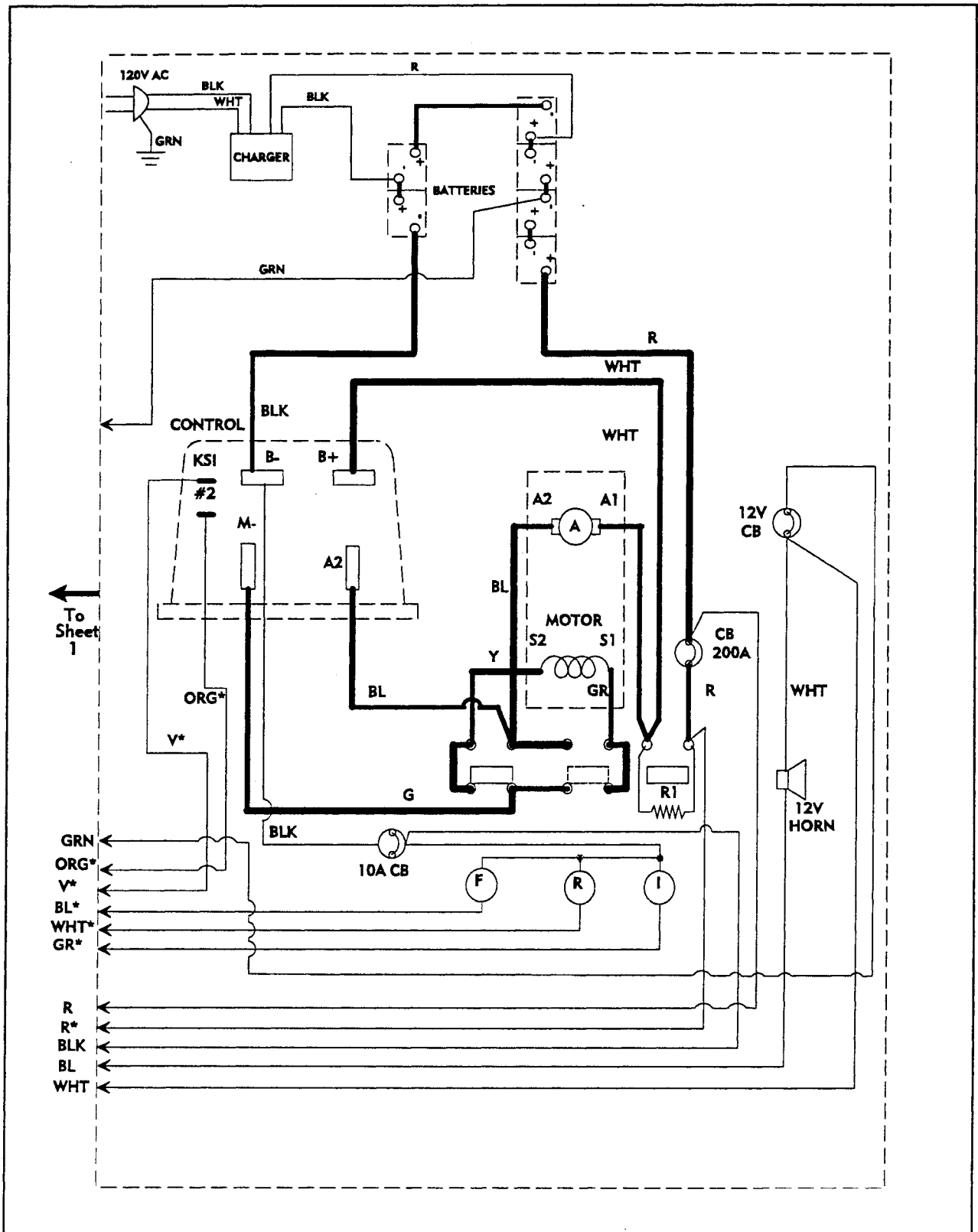

Figure 6 Detailed wiring diagram (sheet 2 of 2)

FRONT AXLE

The front axle is designed for rugged, dependable service when properly maintained and lubricated (see Lubrication Chart in Section 3).

The front axle consists of the following:

- ▣ axle beam
- ▣ hubs and bearings
- ▣ spindles

- ▣ king pins
- ▣ steering drag link
- ▣ steering assembly

The steering worm gear box and steering arm are similar to those used in automobiles and require minimum maintenance (see Figure 11).

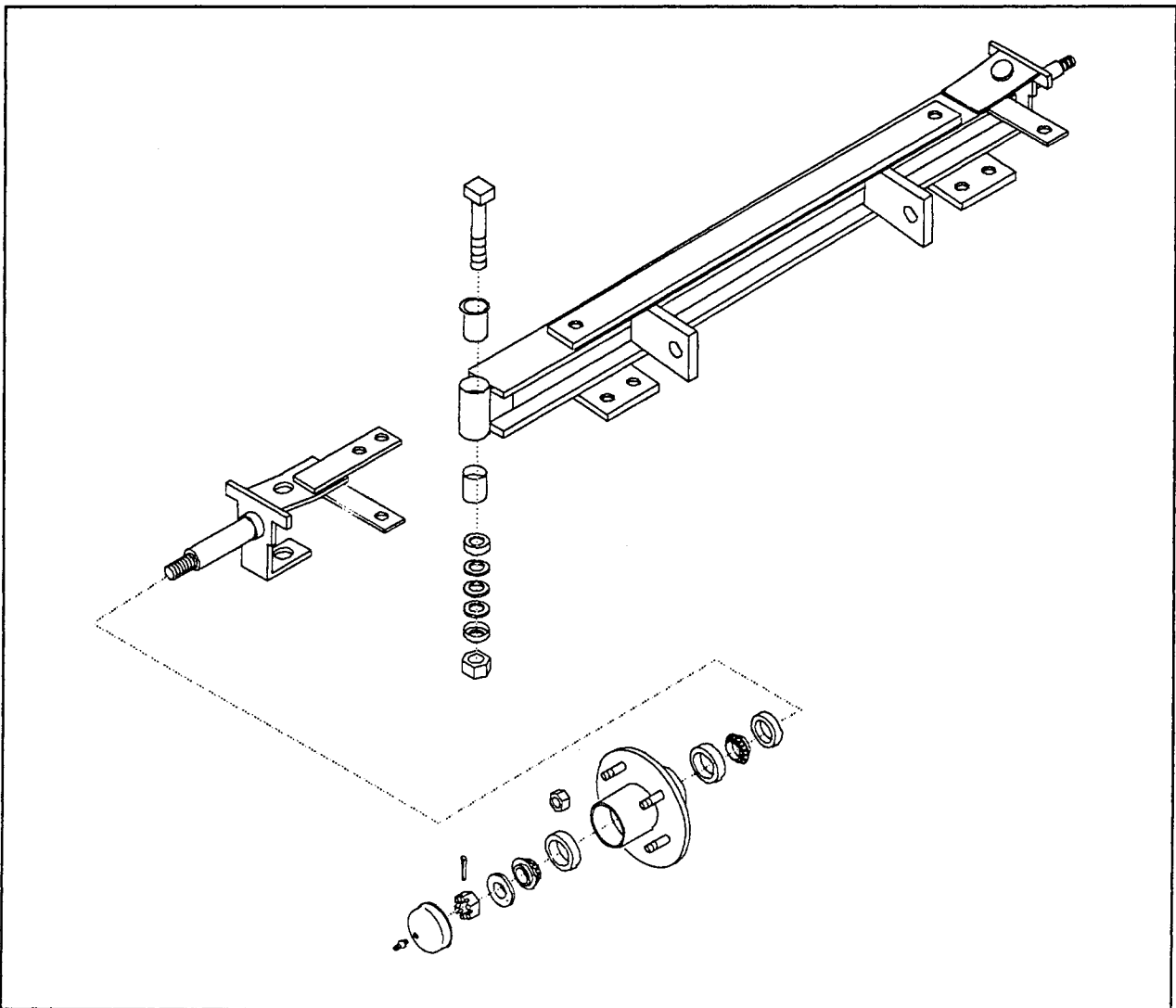

Figure 7 Front axle

Adjusting Bearings

To clean and adjust the front axle bearings, do the following (see Figure 8):

- 1 Remove tire and wheel.

WARNING!

Always use jack stands when raising and supporting the vehicle for inspection or repairs.

- 2 Remove dust cap and cotter pin.
- 3 Unscrew spindle nut.
- 4 Remove outer washer and bearing.
- 5 Remove hub assembly from spindle.
- 6 Remove oil seal and inner bearing.

- 7 Clean roller bearings, spindle and wheel hub with a solvent. Inspect and replace any worn or damaged parts.
- 8 Apply wheel bearing grease to roller bearings.
- 9 Reassemble roller bearings, oil seal, and wheel hub.
- 10 Mount hub assembly onto spindle.
- 11 Install outer washer, and spindle nut.
- 12 Tighten spindle nut until you barely feel the roller bearing drag as you rotate the hub by hand, then back off the spindle nut about 1/4 turn.

Note: *The hub should now turn freely (no bearing end-play or wobble).*

- 13 Replace cotter pin with new one. Install dust cap, tire and wheel.

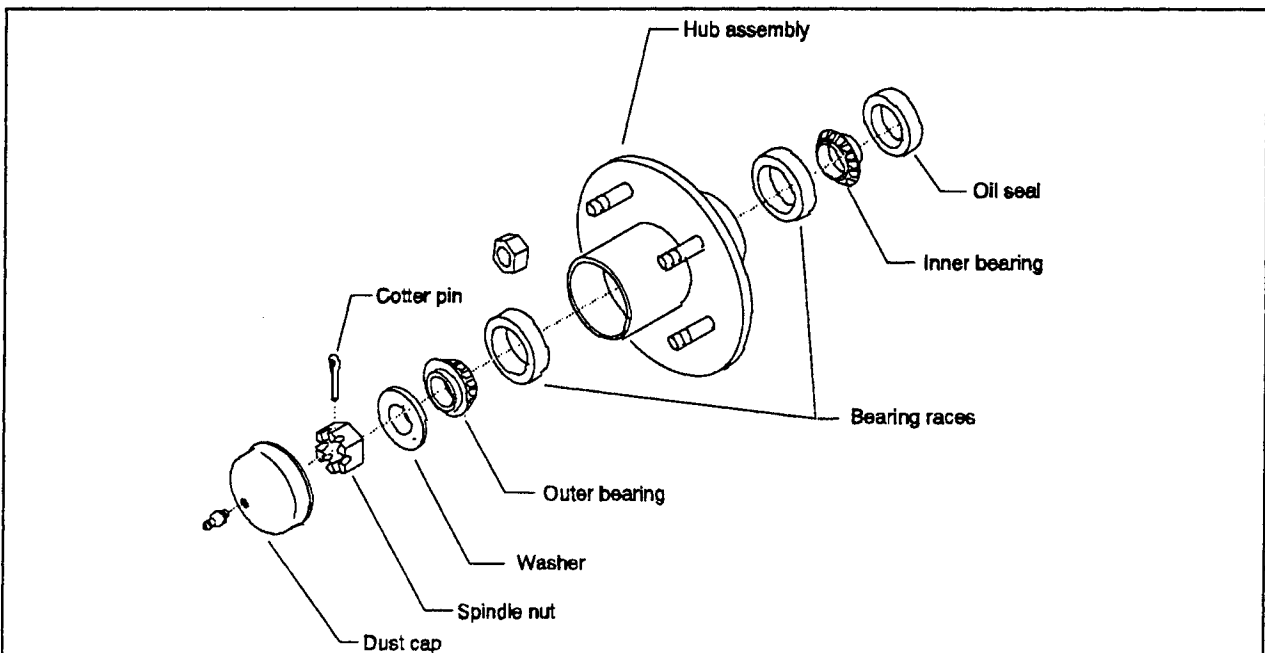

Figure 8 Adjusting front axle bearings

Aligning Front End

To align the front end for toe-in, do the following:

Note: *The caster and camber are set at the factory and do not require adjustment.*

- 1 Raise the front end of the vehicle.

WARNING!

Always use jack stands when raising and supporting the vehicle for inspection or repairs.

- 2 Mark the center of each front tire.

Tip: *Hold a white chalk or other marker against the tire tread at its center while rotating the tire.*

- 3 Lower front end.

- 4 Position front wheels straight ahead.
- 5 Measure the distance between the marks on the back of the front tires.
- 6 Measure the distance between the marks on the front of the front tires. The rear measurement minus the front measurement should be between 0" and $\frac{1}{8}$ ". If the result falls outside this range, continue with the remaining steps.
- 7 Loosen each tie-rod sleeve clamp until the tie-rod can be turned.
- 8 Turn the tie-rod until the difference between the front and rear measurements is between 0" and $\frac{1}{8}$ ".
- 9 Tighten each tie-rod sleeve clamps.

Repairing King Pins and Bushings

To repair the king pins and bushings, do the following (see Figure 9):

- 1** Remove wheel, tire, dust cap and cotter pin.
 - 2** Unscrew spindle nut.
 - 3** Remove outer washer and bearing.
 - 4** Remove hub assembly from spindle.
 - 5** Disconnect ball joints at knuckle weldment.
 - 6** Install spindle nut to protect the threads.
 - 7** Remove king pin locknut from king pin.
 - 8** Remove king pin from knuckle weldment.
- Tip:** Use a soft rod (bronze or aluminum) to drive the king pin up through the knuckle if necessary.
- 9** Remove knuckle and pack bearing from axle sleeve.
 - 10** Press bushings from axle sleeve.
 - 11** Clean knuckle, king pin, axle sleeve and thrust bearing with a solvent or degreaser.

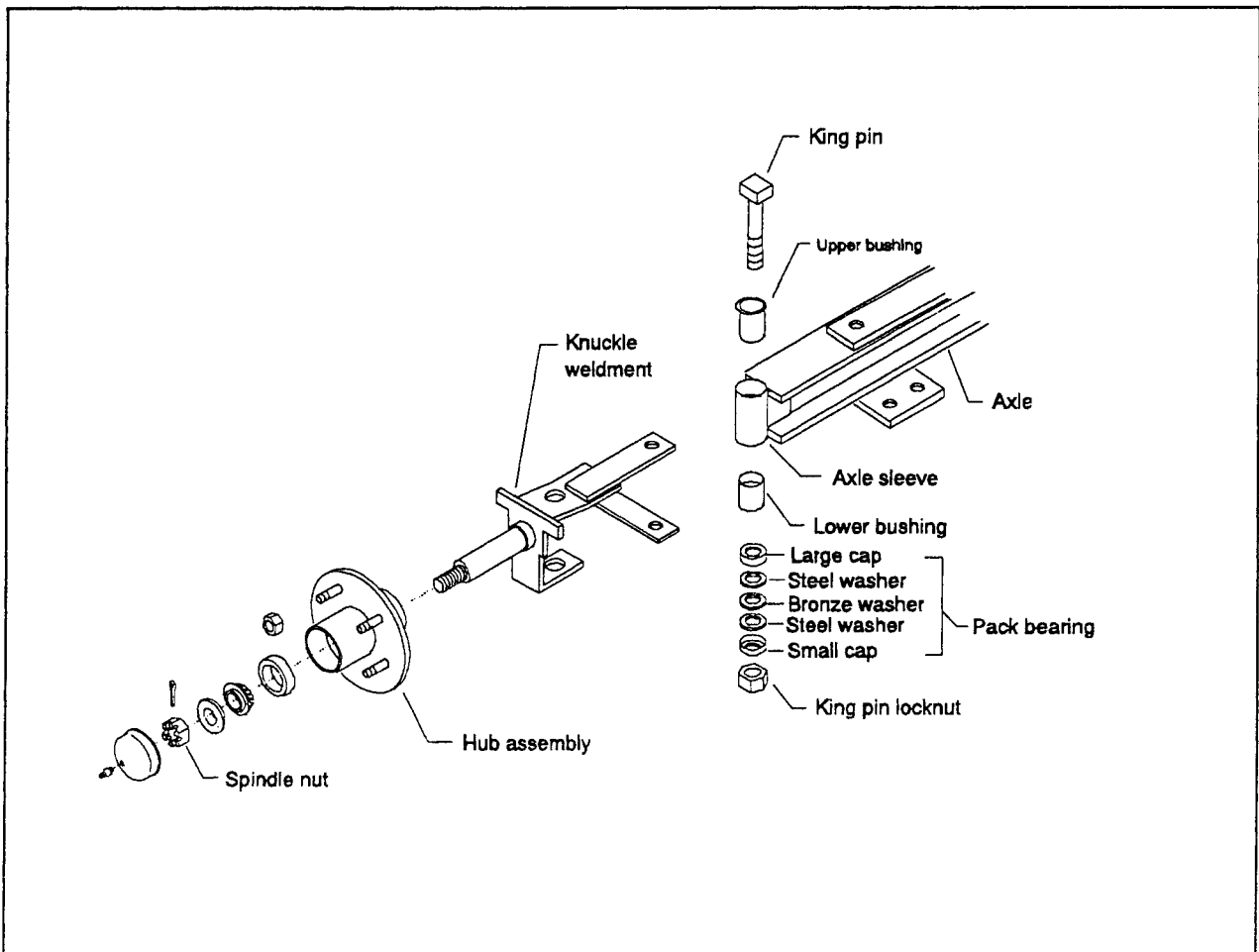

Figure 9 Repairing king pins and bushings

- 12** Press new bushings into sleeve using a bushing press.

Note: *The upper bushing is a special bushing and should be seated on the axle flange.*

Tip: *If you do not have a bushing press, contact your Taylor-Dunn dealer or any automotive supply house or repair shop for this service.*

- 13** Broach or ream the new bushings until the inside diameter is between 0.878" and 0.880".

Note: *Be sure that the bushings are in line with each other. The bottom bushing should be flush with the inside surface. The top bushing should be seated against the axle flange on the end tube.*

- 14** Lubricate the thrust bearing with lithium grease.

- 15** Install knuckle weldments and thrust bearing onto axle weldment.

- 16** Install king pin into knuckle weldment.

- 17** Tighten king pin locknut until it touches the bottom of the knuckle weldment.

Note: *Always use new locknuts when repairing king pins and bushings.*

Note: *When tightening locknut on the king pin make sure that the knuckle weldment rotates freely.*

- 18** Lubricate bushings and king pin with lithium grease using grease fitting.

- 19** Install cleaned and greased hubs and bearings.

- 20** Adjust wheel bearings.

- 21** Install and tighten ball joints.

- 22** Align front end.

Replacing Ball Joint

To replace the ball joint, do the following (see Figure 10):

- 1** Remove wheel and tire.
- 2** Remove cotter pin and ball joint nut from knuckle weldment.
- 3** Disconnect ball joint at knuckle weldment.

Tip: To disconnect ball joint use pickle fork. Put fork between knuckle weldment and head of ball joint. Rap on end of fork until ball joint loosens from weldment.

- 4** Measure position of ball joint.

Tip: Count the number of threads exposed on the ball joint sleeve.
- 5** Loosen ball joint clamps.
- 6** Unscrew ball joint from tie rod.

Caution!

One end of the tie rod uses a right-hand thread; the other end uses a left-hand thread. Be sure to tag and mark which is which when you remove them so you can reinstall them correctly.

- 7** Install new ball joint in same position as the removed ball joint.
 - 8** Install tapered shaft into knuckle weldment.
 - 9** Replace ball joint nut.
 - 10** Tighten ball joint into knuckle weldment.
 - 11** Replace cotter pin with new one..
 - 12** Make necessary adjustments to center the steering wheel when the tires are aligned.
- Note:** If the ball joint was part of a new tie rod, check the toe-in alignment and adjust as necessary.
- 13** Tighten both ball joint clamps securely.
 - 14** Lubricate ball joints through the grease fittings.

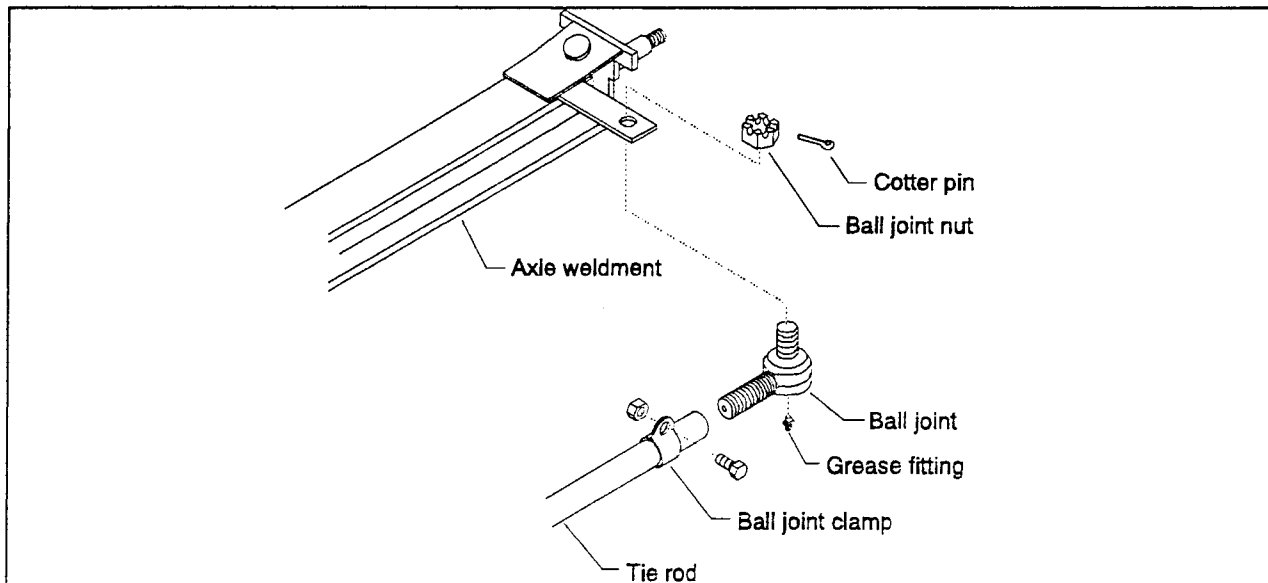

Figure 10 Replacing ball joints

Replacing Steering Worm

To replace the steering worm assembly, do the following (see Figure 11).

- 1** Pry steering wheel cap up to expose locknut.
- 2** Unscrew terminals from horn button.
- 3** Cut terminals from horn button wires.
- 4** Pull wires out through bottom of steering column.
- 5** Remove steering wheel pitman arm.
Tip: Use wheel puller.
- 6** Remove mounting bolts attaching steering gear case to frame.

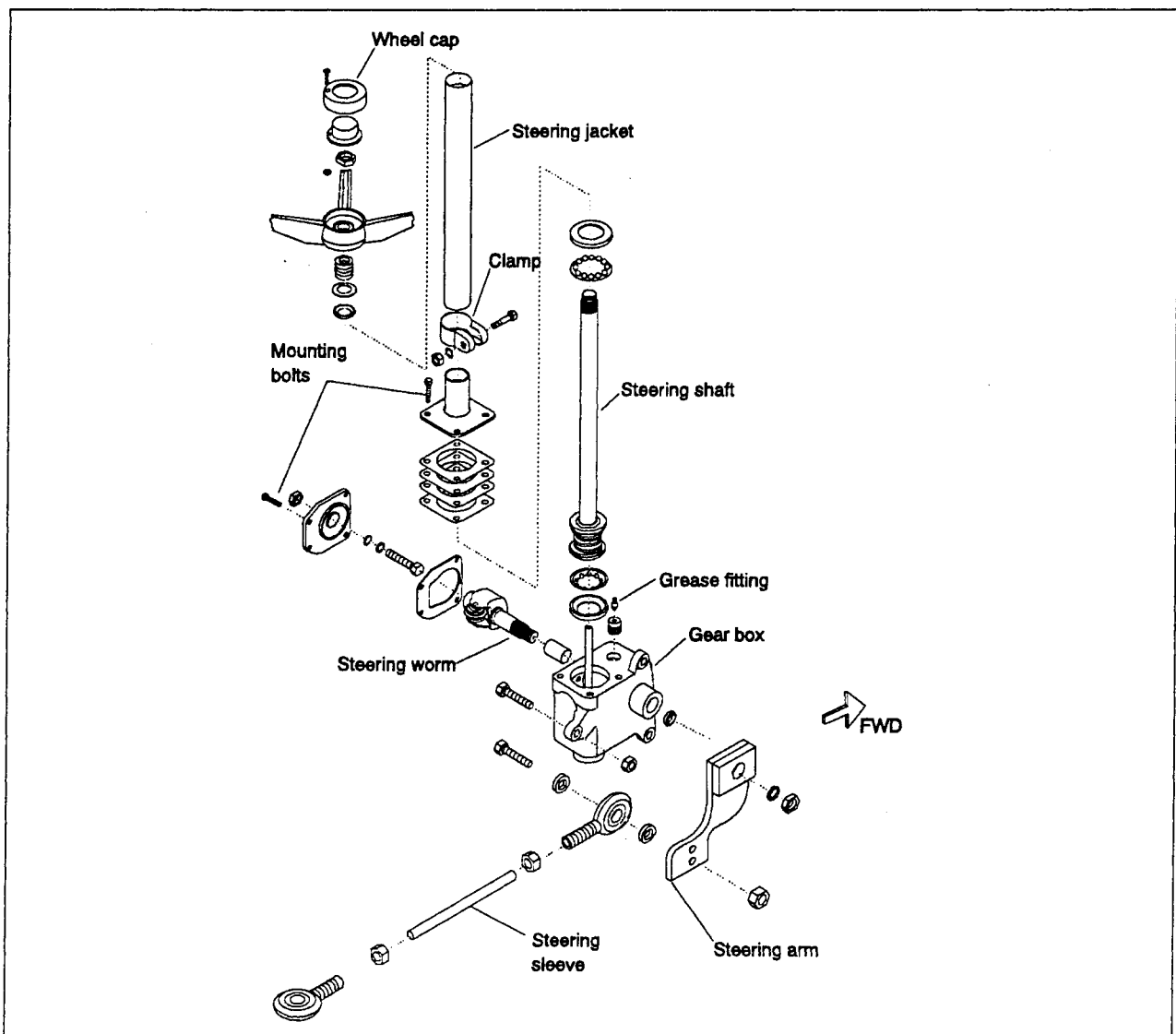

Figure 11 Replacing the steering gear

7 Carefully remove the steering column out of the bottom of the frame.

8 Install new steering column shaft and worm assembly using the mounting bolts removed earlier.

Note: *Be sure to use new locknuts.*

9 Align front wheels straight ahead.

10 Install steering wheel (but do not tighten yet).

11 Center the steering column shaft and worm assembly.

Tip: *Turn the wheel full left, then turn right three turns to center the wheels.*

12 Install steering arm.

13 Tighten the locknut.

Note: *The steering mechanism must turn equally in each direction. If not, you must reinstall the steering arm in the proper position.*

14 Crimp new ring terminals (75-418-70) onto horn button wires.

Tip: *Use a wire crimping tool or pliers. Be sure to strip the wire ends first to make electrical contact with the terminals.*

15 Screw terminals to horn button.

16 Replace steering wheel cap.

17 Lubricate the steering worm through the grease fitting.

18 Check for smooth steering.

REAR AXLE ASSEMBLY

The rear axle assembly consists of the following:

- differential
- rear axles

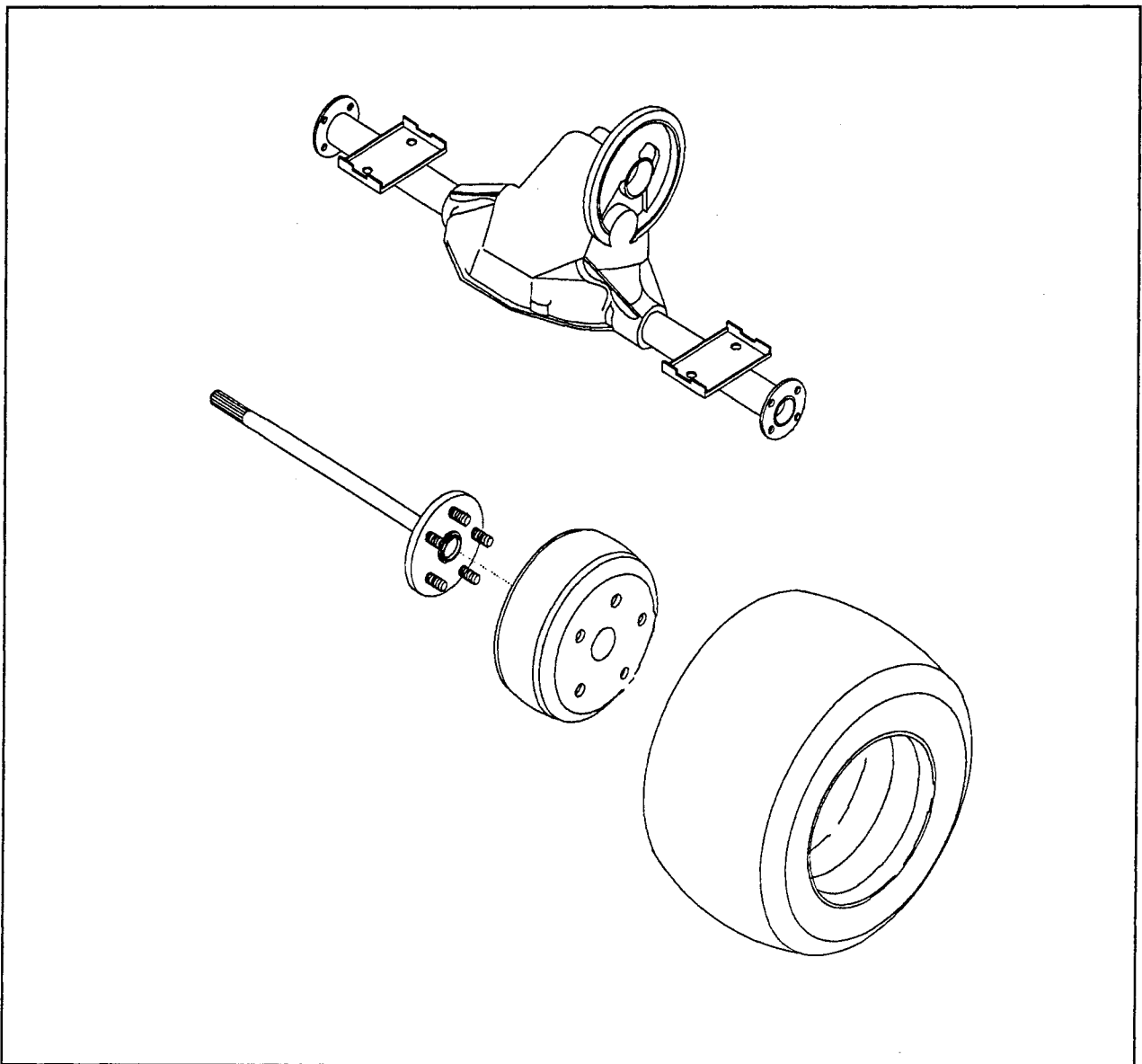

Figure 12 Rear axle assembly

Repairing the Differential

To repair the differential, do the following (see Figure 13):

- 1** Drain oil from differential.
- 2** Remove axle shafts from differential. (see repairing rear axle page 52).
- 3** Remove cover plate screws.
- 4** Remove cover plate from differential housing.

Caution!

Make sure as not to damage the housing sealing surface or deform the cover plate.

- 5** Remove bearing cap screws and remove bearing caps.

Note: Bearing caps are marked for identification. During reassembly, make sure they are put back in their original position.

- 6** Remove differential case assembly from housing.

- 7** Remove differential bearings from each side of the case.

Tip: Use a bearing puller to remove bearings.

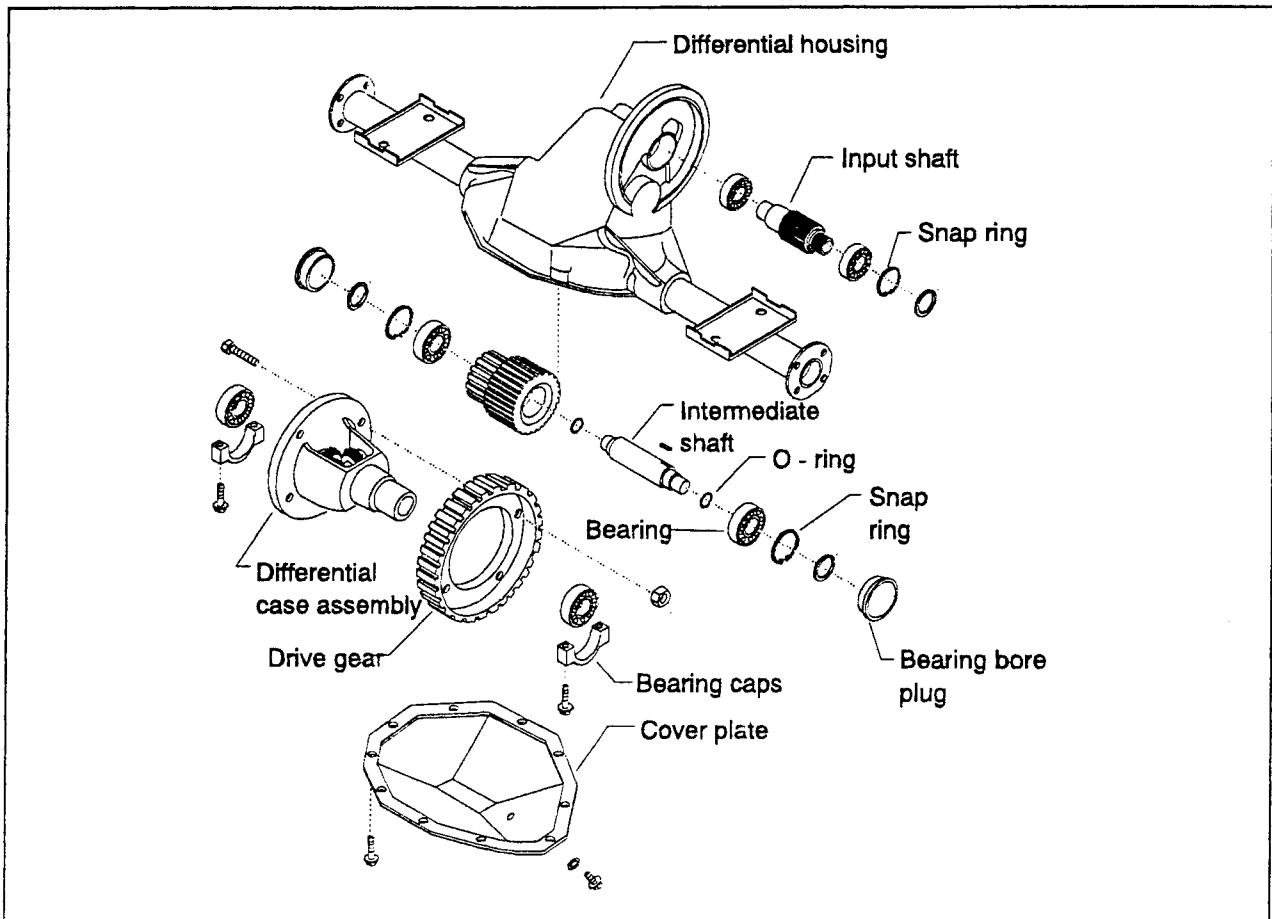

Figure 13 Repairing the differential

- 8** Remove drive gear from differential case.
- 9** Punch or drill about a 1/8" diameter hole in the center of each bearing bore plug.
- 10** Insert a suitably sized sheet metal screw into hole until the bore plug is forced out of the bearing bore.
- 11** Remove snap ring from each bearing bore.
- 12** Drive the intermediate shaft from the flange side of housing.
- Tip: Use a brass drift pin to drive the shaft into the differential housing.*
- 13** Remove intermediate bearing from flange side of housing.
- 14** Remove intermediate bearing on opposite side of housing.
- Caution:**
-
- Shaft and gear assembly must be supported by hand as not to damage gear teeth.
-
- Note: Small end of intermediate shaft and gear assembly must be tilted toward opening in bottom of housing for removal.*
- 15** Remove O-ring from each end of the intermediate shaft.
- 16** Remove snap ring from input shaft bore.
- 17** Pull input shaft assembly from housing. The input shaft assembly should slide out of housing easily.
- 18** Remove bearings from input shaft.
- Tip: Use an arbour press and bearing support to remove input shaft bearings.*
- 19** Remove O-rings from outer input bearing bore and both intermediate bearing bores.
- 20** Inspect all parts for signs of wear or damage.
- Note: Bearings and seal surfaces should be inspected for pitting, wear, or overheating. Inspect gears for pitting, wear or scoring. Replacement of these parts can prevent premature failure.*
- 21** Parts should be cleaned with emulsion cleaners or petroleum based cleaners.
- 22** Lubricate all parts liberally with SAE 30 oil.
- 23** Press inner and outer bearings on input shaft to bearing shoulders.

- 24** Reinstall input shaft. Bearings and shaft should slide easily into housing.

Tip: A plastic or leather mallet could be used to tap the shaft into position if resistance is encountered.

- 25** Install outer snap ring at input shaft bore.

- 26** Install O-rings onto intermediate shaft.

- 27** Assemble intermediate shaft and gear assembly thru bottom opening in housing.

Note: Small end of intermediate shaft and gear assembly must be tilted toward bottom opening until bearing trunnion visually engages intermediate bores.

- 28** Align both bearing trunnions with intermediate bores.

- 29** Insert the flanged side bearing into opening.

Note: To seat the bearing past the O-ring, a plastic or leather mallet may be required.

- 30** After flanged side bearing is seated install snap ring.

- 31** Repeat procedure for opposite side bearing and snap ring.

- 32** Align final drive gear mounting holes with differential case and install the four bolts and nuts.

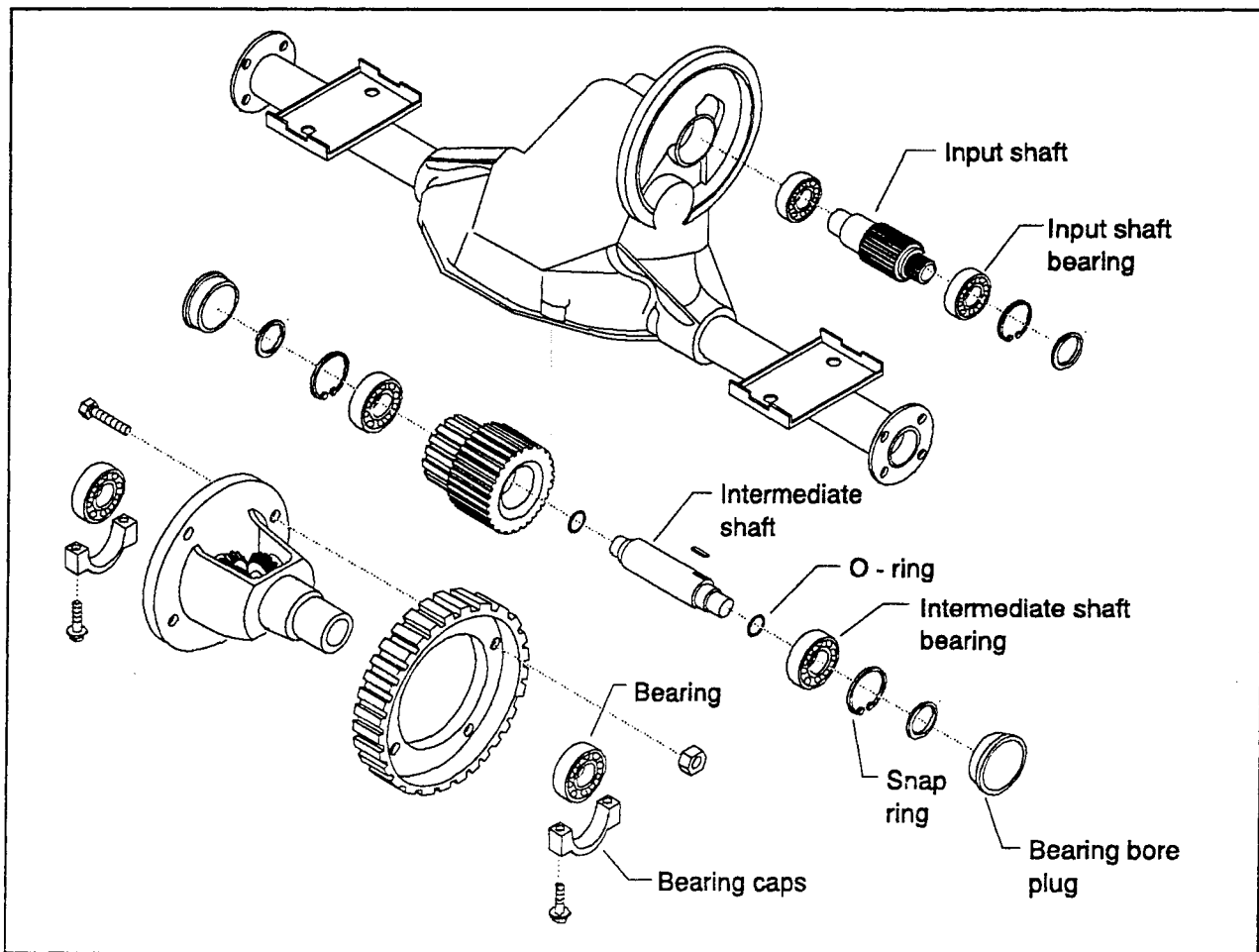

Figure 14 Removal of bearings from differential

Note: Bolts should be installed from the differential flange side. Torque to 35-45 Ft. Lbs.

33 Press differential bearing onto each trunnion of differential case.

34 Position housing with opening up and insert differential case, final drive gear, and bearing assembly into housing.

35 Install differential bearing caps.

Note: Bearing caps are marked for identification. Letters or numbers are stamped in horizontal or vertical position. During reassembly, they must return to their original positions.

36 Install four cap screws into bearing caps and torque to 35-45 Ft. Lbs.

37 Install the cover plate and cover plate screws and torque to 18-28 Ft. Lbs.

38 Install new intermediate bore plugs to both sides of housing.

Note: Bore plugs should be firmly against snap rings, when fully seated.

Tip: Bore plugs can be installed using a properly sized driver and hammer.

39 Fill differential housing with about one pint of SAE 30 oil.

Repairing the rear axle shaft, bearing, and oil seal

1 Remove the brake drums from axle.

2 Remove axle retaining bolts and nuts.

Tip: To remove axle and bearing use a slide hammer attached to the axle flange.

3 Remove the bearings from the axle shafts.

Tip: Support the brake torque spider on an arbor press, and apply pressure to the splined end of the axle shaft.

4 Remove the oil seals.

Caution!

Be sure not to damage seal seating surface.

Tip: Use an oil seal puller, attached to a slide hammer to remove oil seal.

5 Bearing and seal surfaces should be inspected for pitting, wear, and overheating.

6 Inspect axle shafts for worn splines, bends, or cracks.

Note: Replacement of these parts can prevent premature failure.

7 Install shaft seals into axle shaft tube.

Note: Seal should be installed about 1.208" to 1.228" into axle shaft tube.

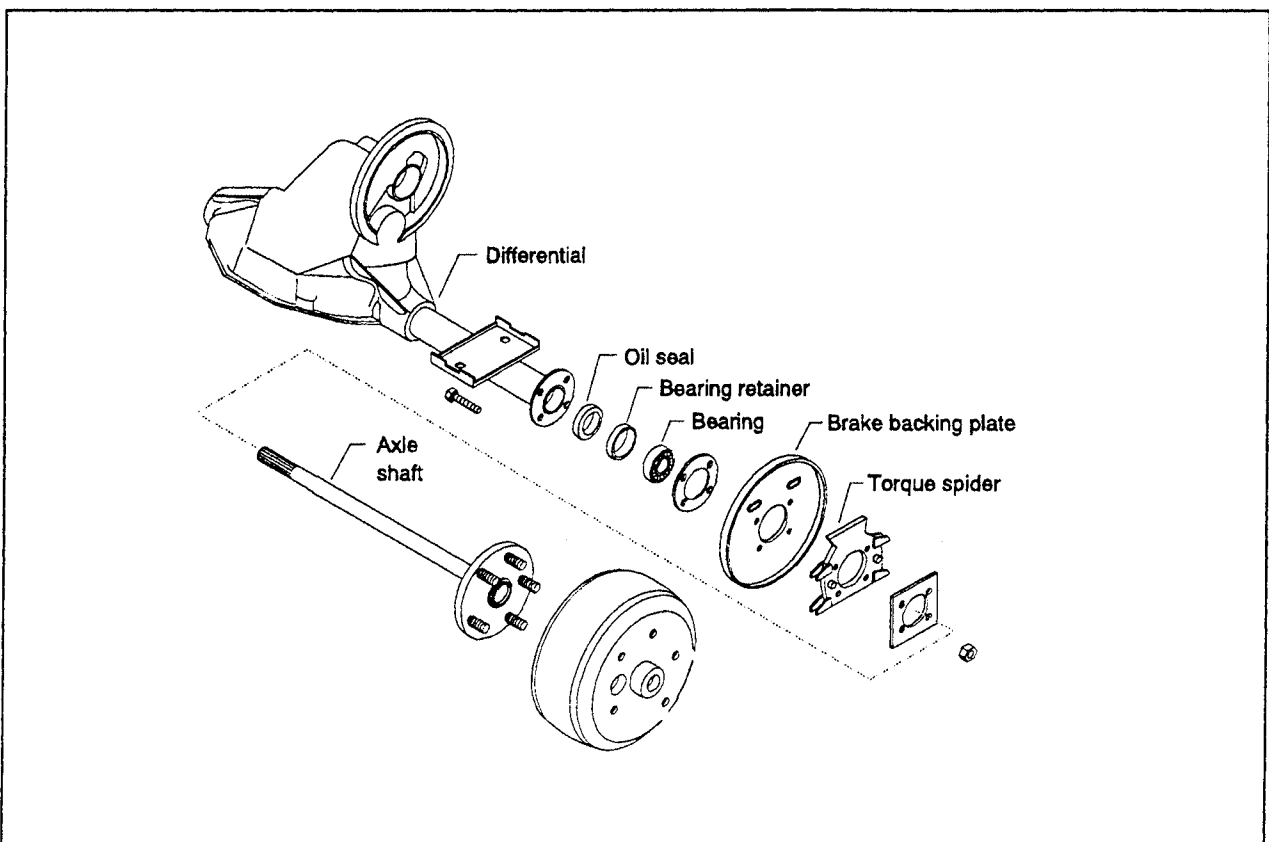

Figure 15 Repairing axle shaft, bearing and oil seal

Tip: Seal lip should be coated uniformly with light oil or grease before inserting axle shaft.

- 8** Press the bearings and bearing retainers onto axle shafts. The bearing should seat to the shoulders.

Note: Remember to slip on the outer seals, brake torque spiders, and brake backing plate before pressing on the bearings and retainers.

- 9** Insert the axle shaft assemblies into tubes until they are seated firmly against the inside bearing seats.

Note: Rotation of shaft may be required to engage differential splines, during installation.

- 10** Install axle retaining bolts and nuts

- 11** Install brake drums onto axle shafts.

SPEED CONTROL PANEL

The speed control module consists of:

- accelerator module (not on panel)
- horn
- solenoids
- speed controller
- breakers

Note: In order to gain access to the control panel you must remove the 2nd passenger seat, slide deckboard forward and remove deckboard.

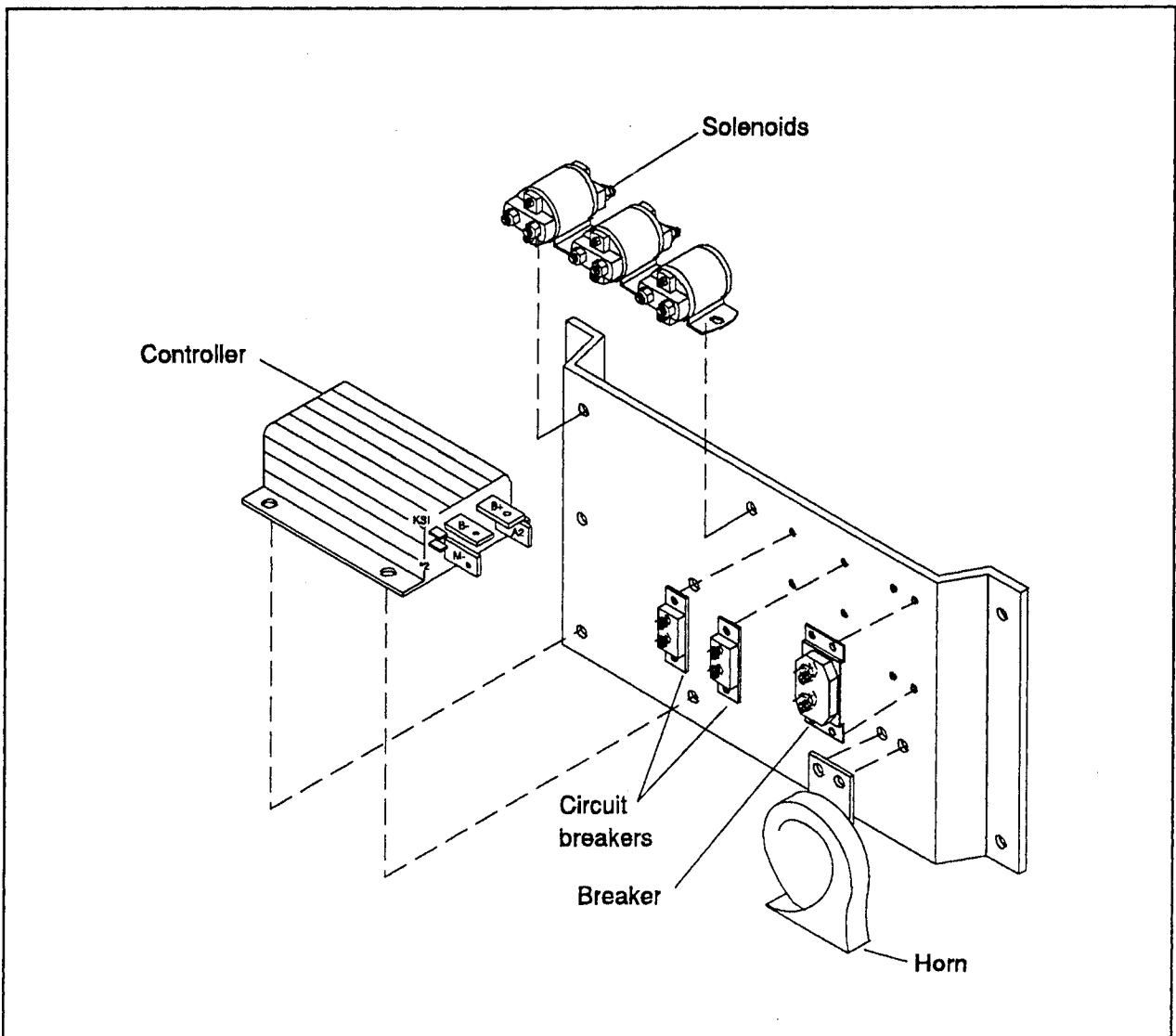

Figure 16 Speed control panel

Accelerator Module

The accelerator module was designed to increase the reliability of the control system. The module requires no maintenance and the components give solid state performance.

Note: *There are no adjustments that need to be made to the accelerator module. However make sure the accelerator pedal is up and the accelerator lever is resting against the accelerator bracket. This is the off position.*

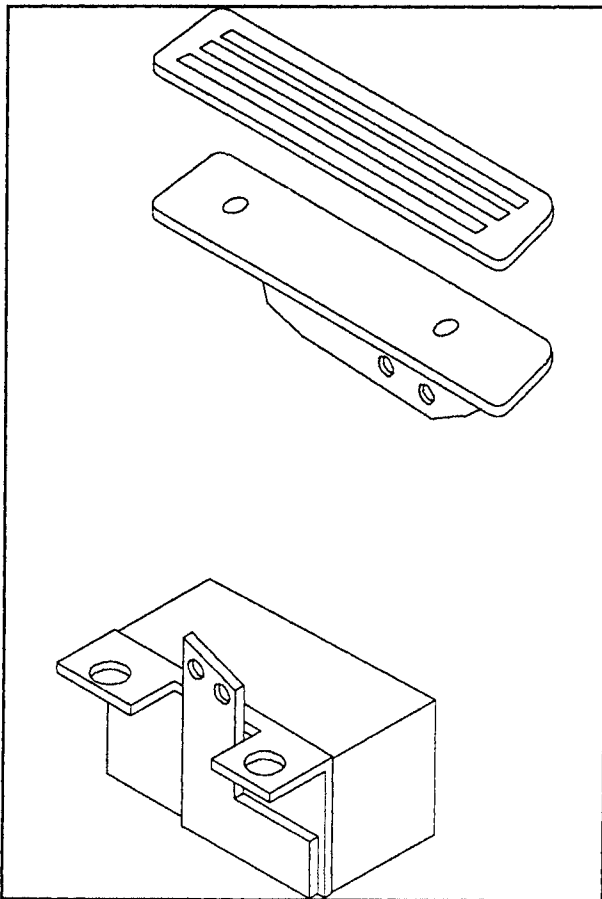

Figure 17 Accelerator module

Battery Charger

The Lestronic II battery charger is a reliable, line compensating unit. When used according to instructions, the charger will tend to lengthen battery life.

WARNING!

When working near capacitor terminals be sure charger is turned off. Before performing service, disconnect AC and DC leads. Discharge capacitor before servicing.

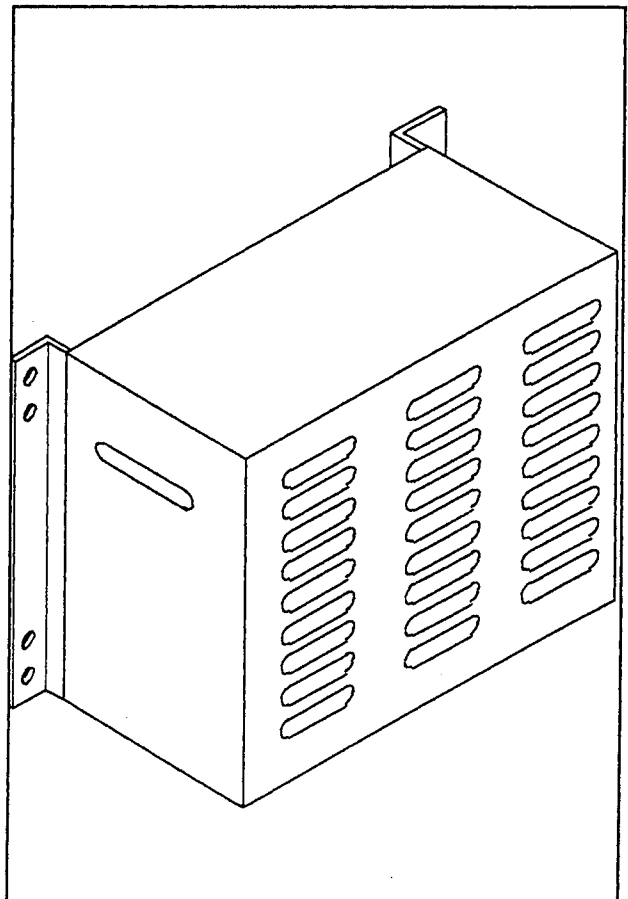

Figure 18 Battery charger

STORAGE:

The Lestronic II battery charger may be left connected to the batteries and should be turned on once a month. In extreme cold conditions it may be necessary to charge more frequently. After each charge cycle the charger should be checked to ensure that it has turned off.

Note: Please refer to the Lestronic II manual supplied with this vehicle for service and maintenance procedures.

Solenoid Assembly

To repair or replace solenoids do the following:(see figure 18).

WARNING!

Disconnect the main positive and negative battery leads and remove the key before working on any part of the vehicles electrical system.

- 1** Remove screws, nuts and washers on solenoids.
- 2** Remove wires and buss bars.

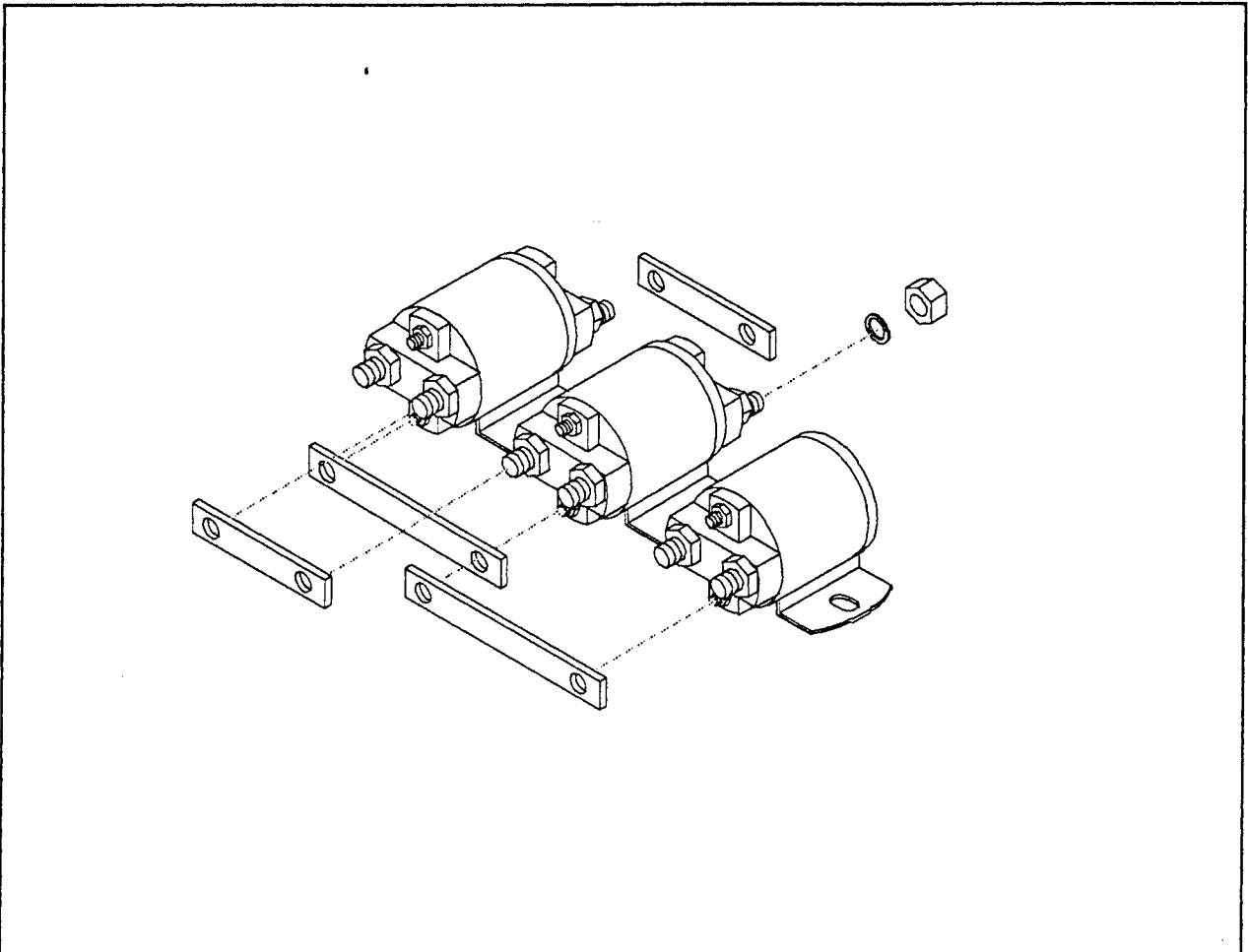

Figure 18 Solenoid assembly

Note: Mark the position of all wires and buss bars prior to removal. Make sure they are put back in their original position.

- 3** Remove solenoids from panel.
- 4** To install solenoid, reverse procedures.

Speed Controller

The controller is designed specifically for use with electric vehicles. Its function is to provide full control of the vehicles speed under all operating conditions.

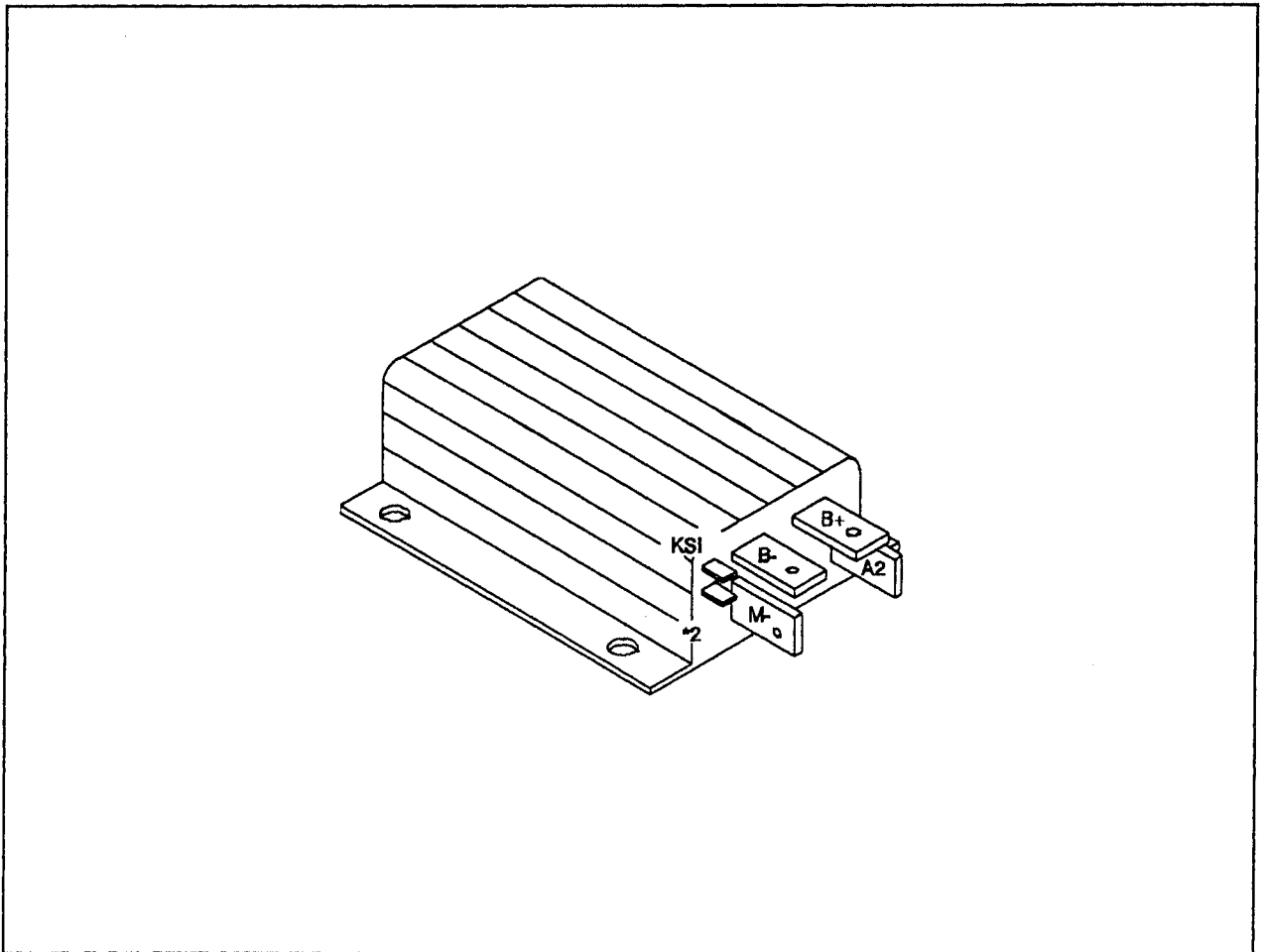

Figure 19 Speed controller

Troubleshooting Guide

Note: Before proceeding with any troubleshooting, understand the basic principles of operation and be familiar with component testing and replacement procedures.

WARNING!

Disconnect the main positive and negative battery leads and remove the key before working on any part of the electrical system.

Testing Accelerator Control

To test accelerator control do the following:

- 1** Unplug the accelerator wire harness.
- 2** Using an accelerator module test box, plug in the accelerator module pigtail.
- 3** Connect the B+ and B- terminals on the test box to the battery main positive and negative terminals.

Note: Make sure the batteries are in good condition and fully charged.

- 4** Set the V.O.M. to DC volt range to make the measurements. All readings must agree with the following tables.

- 5** With the pedal up, the following measurements should be found.

Pin Position	Pedal Up
2	0 Volts
4	36 Volts minimum
5	0 Volts
6	0 Volts

- 6** Slowly depress the pedal. When pin #5 measures 36 volts, the following measurements should be found.

Pin Position	#5 at 36 Volts
2	6.0 - 6.3 Volts
4	36 Volts minimum
5	36 Volts minimum
6	0 Volts

- 7** With the pedal fully depressed, the following measurements should be found.

Pin Position	Pedal Fully Depressed
2	11.0 - 11.5 Volts
4	36 Volts minimum
5	36 Volts minimum
6	36 Volts minimum

- 8** If the accelerator module fails it will need to be replaced.

- 9** Unplug the test pigtail and plug in the accelerator wire harness.

Testing Controller Power

WARNING!

Raise and brace the rear of the vehicle. The drive wheels must not touch the ground. Always use jack stands when supporting the vehicle.

To test the controller power do the following:

Caution!

Check battery polarity. Severe damage to the controller will result if battery polarity is reversed.

Note: Make sure the batteries are fully charged before proceeding.

- 1** Make sure that the keyswitch is in the off position.
- 2** Check to see that the negative (-) battery terminal is connected to the B- terminal of the controller.
- 3** Connect the negative (-) voltmeter lead to the B- terminal on the controller.
- 4** Connect the positive (+) voltmeter lead to the battery side of the isolator solenoid.
- 5** The measurement should be full battery voltage.

Note: If voltage is not present, check for loose wires, bad batteries, or faulty main circuit breaker.
- 6** Connect the positive (+) voltmeter lead to the controller B+ terminal.
- 7** The voltmeter should have a voltage reading of 1 to 5 volts less than the full battery voltage.

Note: If the voltage is zero or close to zero, the trouble is either a defective controller, a defective resistor across the isolator solenoid, or the wire between the isolator solenoid and the controller.
- 8** Trace the wire to make sure it is connected correctly.
- 9** Remove and test the resistor on the isolator solenoid with an ohmmeter. The ohmmeter should read 250 ohms.
- 10** If the voltmeter reads full battery voltage, then the isolator has welded and must be replaced.

Test for Solenoid Operation and Keyswitch Input

WARNING!

Raise and brace the rear of the vehicle. The drive wheels must not touch the ground. Always use jack stands when supporting the vehicle.

To check for solenoid operation and keyswitch input do the following:

- 1** Place the forward/reverse switch in the off position.
- 2** Turn key on and depress the pedal until the first microswitch in the accelerator module operates.
- 3** Measure the voltage across the coil terminals on the isolator solenoid.

Note: You should measure full battery voltage.

- 4** Place the forward/reverse switch in reverse.

- 5** Measure the voltage across the reverse solenoid.

- 6** You should measure full battery voltage.

- 7** Place the forward/reverse switch in forward.

- 8** Measure the voltage across the forward solenoid.

- 9** You should measure full battery voltage.

Note: The keyswitch input terminal is KSI, top push on the terminal.

- 10** Check for loose faulty or misconnected wires, keyswitch, or forward/reverse switch if a low voltage reading.

Note: If the contactor coils and keyswitch input are getting voltage, make sure the contactors are working by connecting the voltmeter across the power terminals. Contacts should show no voltage drop.

- 11** Replace solenoid if a voltage reading indicates bad or worn contacts.

Test for Controller Output

WARNING!

Raise and brace the rear of the vehicle. The drive wheels must not touch the ground. Always use jack stands when supporting vehicle.

To test the controller output do the following:

- 1** Connect the voltmeter positive (+) lead to the controller B+ terminal.
- 2** Connect the negative (-) lead to the M-terminal.
- 3** Turn on the keyswitch.
- 4** Put the forward/reverse switch in forward or reverse.

Note: The voltmeter should read zero with the pedal up and full battery voltage with the pedal down.

- 5** If incorrect readings are indicated replace the controller.
- 6** Measure the current in the M- lead. The measurement should read 25-60 amps.

Tip: Use a shunt/meter setup or a clamp-on DC ammeter to measure the current.

Note: If no current is flowing in the M- lead, there is an open circuit in the motor or wiring.

- 7** Check directional solenoids to see that they are operating and the contacts are closing.
- 8** Check the motor armature and fields for opens.

Note: If current is flowing in the M- lead and the vehicle does not operate properly, there may be a short in the motor or the controller plug diode.

To check the plug diode do the following:

- 1** Disconnect the battery leads.
- 2** Disconnect the A2 terminal on the controller.

Connect an ohmmeter between the A2 and the B+ terminals on the controller.

Note: You are testing for the presence of the diode in the controller. When you swap the leads on the ohmmeter it should measure a low resistance one way and a high resistance the other.

Replace the controller if the diode is shorted. If the plug diode is not shorted, there is a short in the motor circuit.

**This page
intentionally left
blank**

SECTION 5: ILLUSTRATED PARTS BREAKOUT

ACCELERATOR, BRAKE PEDAL, HAND BRAKE LINKAGE

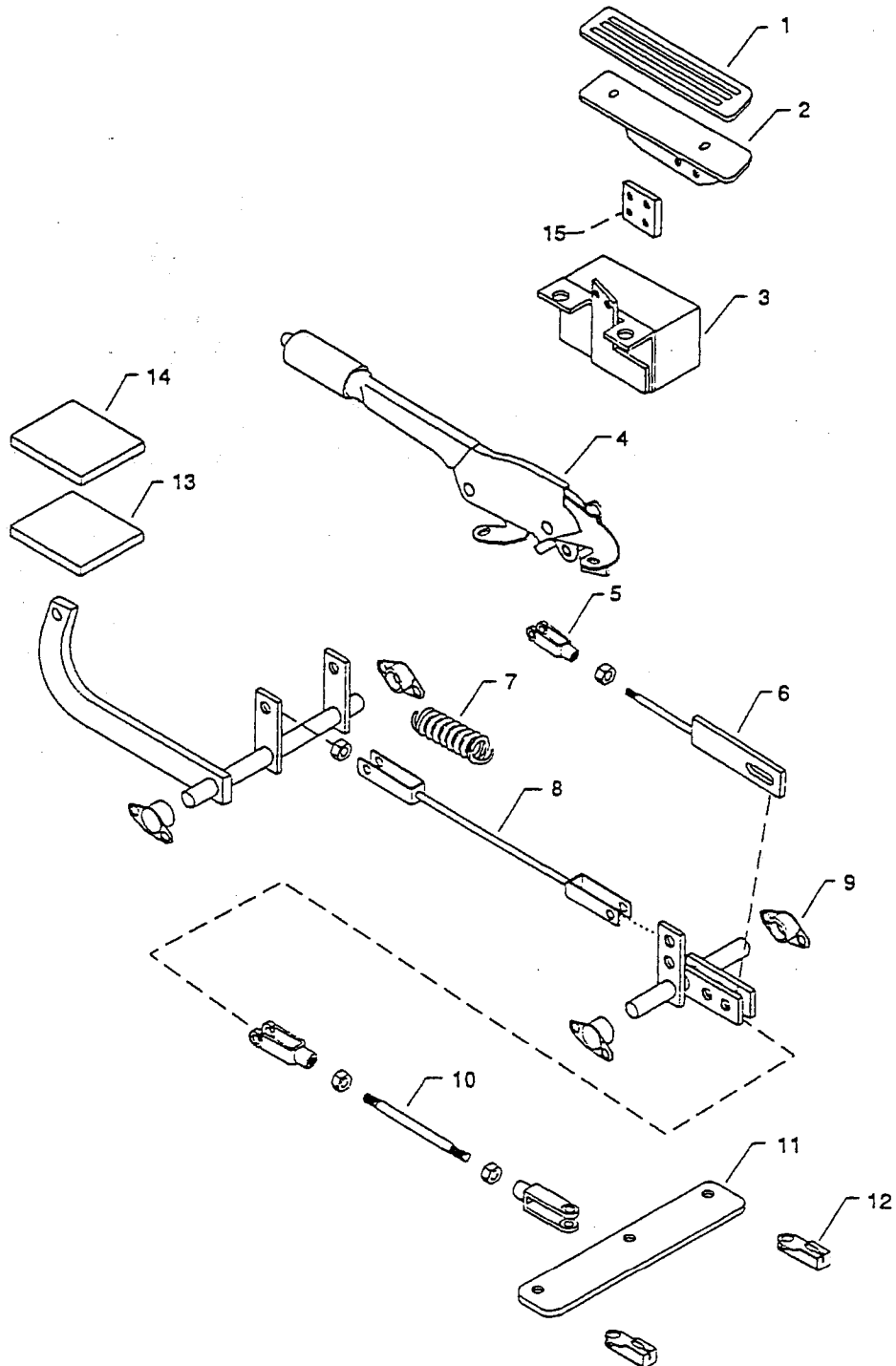

ACCELERATOR, BRAKE PEDAL, HAND BRAKE LINKAGE			
ITEM #	PART NUMBER	DESCRIPTION	QTY.
1	98-254-00	Pad, Accelerator Pedal, Aluminum	1
2	98-254-25	Weldment, Mount, Pedal, Raised	1
3	62-033-00	Module, Accelerator	1
4	51-343-10	Lever, Hand Parking Brake	1
5	96-763-00	Clevis	3
6	00-240-00	Linkage, Hand Park Brake	1
7	85-250-00	Spring, Release, 1" x 3 ⁷ / ₈ "	1
8	96-818-10	Assembly, Cable	1
9	80-410-20	Bearing, Flange	4
10	01-240-01	Rod, Brake Threaded	1
11	01-200-47	Bar, Brake, Equalizer	1
12	96-754-00	Clevis	2
13	01-432-98	Weldment, Brake Pedal	1
14	98-200-00	Pad, Brake Pedal, Rubber	1
15	01-240-02	Adapter, Accelerator Pedal	1

FRONT AXLE

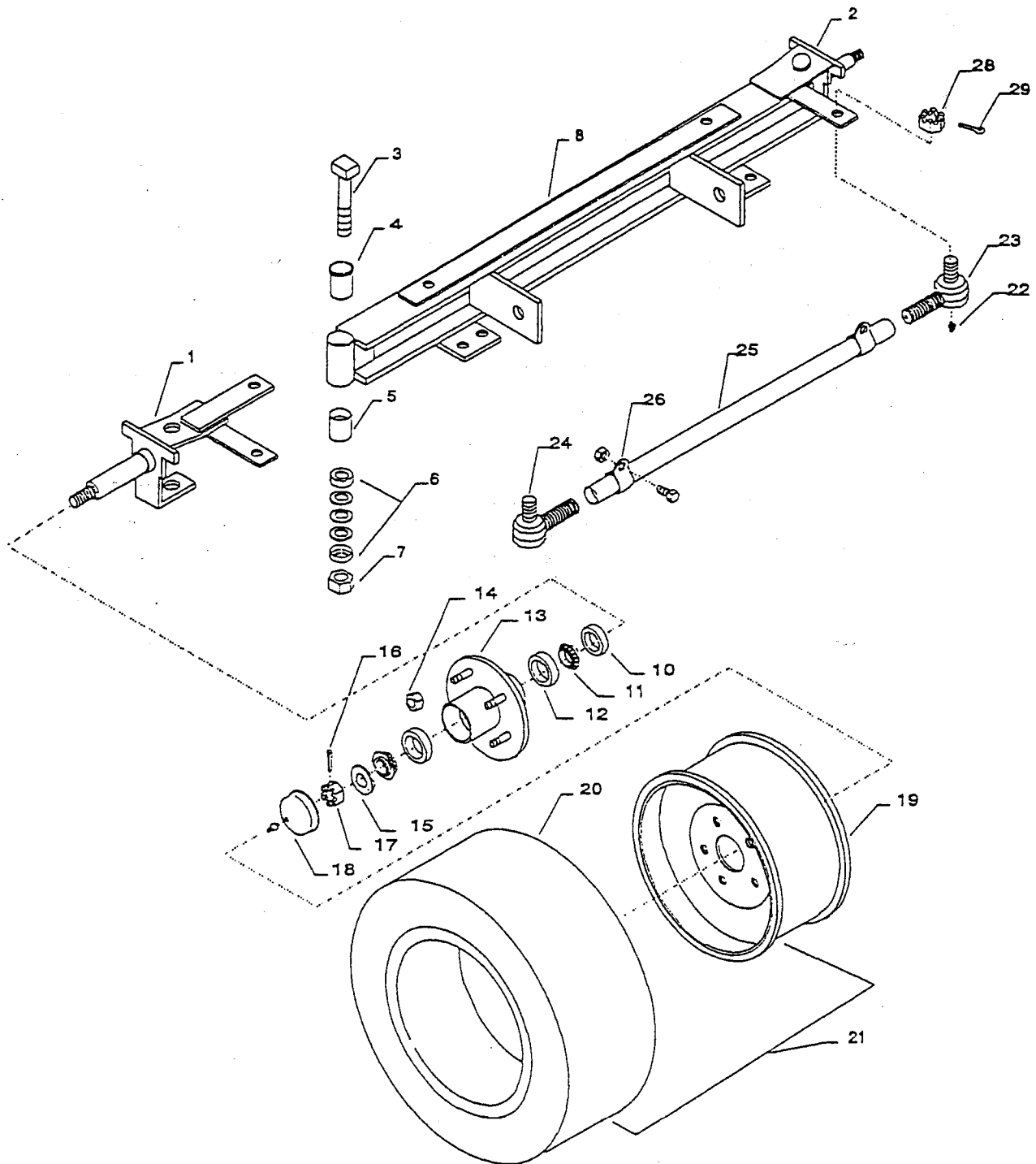

FRONT AXLE			
ITEM #	PART NUMBER	DESCRIPTION	QTY.
1	14-200-90	Yoke, Front Axle, Left	1
2	14-200-91	Yoke, Front Axle, Right	1
3	21-009-10	King Pin, .7/8"	2
4	32-200-00	Bushing, .7/8" x 1"	2
5	32-204-00	Bushing, .7/8" x 10"	2
6	80-309-10	Assembly, Pack Bearing	2
7	88-289-81	Locknut, Hex Head, NF, .7/8"	2
8	00-240-01	Axle, Front	1
9	87-071-00	Fitting, Grease	2
10	45-338-00	Seal, Oil	2
11	80-017-00	Bearing, Roller, Tapered	2
12	80-103-00	Race, Bearing, Tapered	2
13	12-124-00	Hub, Wheel, 5-Stud	2
14	97-236-00	Nut, Lug	10
15	88-228-61	Washer, SAE, 3/4"	2
16	88-527-11	Cotter Pin, Steel	2
17	88-239-85	Slotted Nut, Hex Head, NF, 3/4"	2
18	92-104-00	Dust Cap with Grease Fitting	2
19	12-020-00	Wheel, 5-Hole, 18 x 8.50	2
20	10-093-00	Tire, Terra, 18 x 8.50	2
21	13-746-10	Assembly, Tire and Wheel, 18 x 8.50	2
22	87-074-00	Fitting, Grease	2
23	86-501-99	Ball Joint, Right	1
24	86-501-98	Ball Joint, Left	1
25	18-041-00	Sleeve, Steering	1
26	86-510-00	Assembly, Ball Joint Clamp	2
27	18-041-10	Assembly, Steering Sleeve	1
28	88-159-85	Slotted Nut, Hex Head, NF, 1/2" - 20	2
29	88-527-11	Cotter Pin, Steel	2

Add item 8a, K5-506-98, Front axle beam for hyd brakes.

FRONT AXLE SUSPENSION

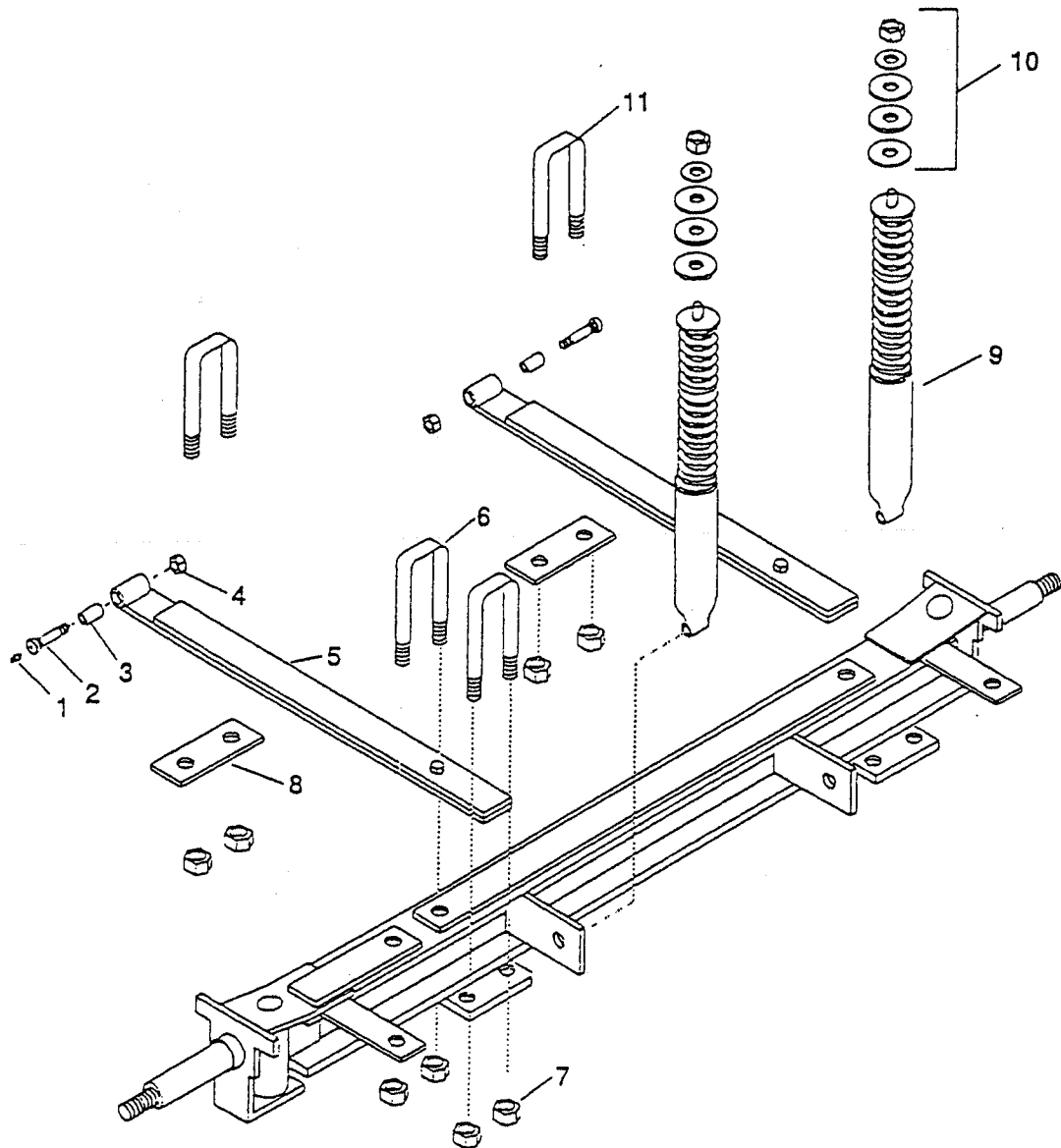

FRONT AXLE SUSPENSION			
ITEM #	PART NUMBER	DESCRIPTION	QTY.
1	87-074-00	Fitting, Grease	2
2	96-248-01	Bolt, Spring, with Grease Fitting	2
3	32-213-00	Bushing, Nylon	2
4	88-179-86	LockNut, Hex Head	2
5	85-506-05	Spring, 2 Leaf	2
6	96-123-00	U-Bolt	4
7	88-149-81	Locknut, Hex Head, NC, 1/2"	12
8	16-872-00	Strap, Shackle	2
9	86-006-00	Absorber, Shock	2
10	86-006-01	Kit, Hardware, Shock Absorber	2
11	96-120-00	U-Bolt	2

INSTRUMENT PANEL

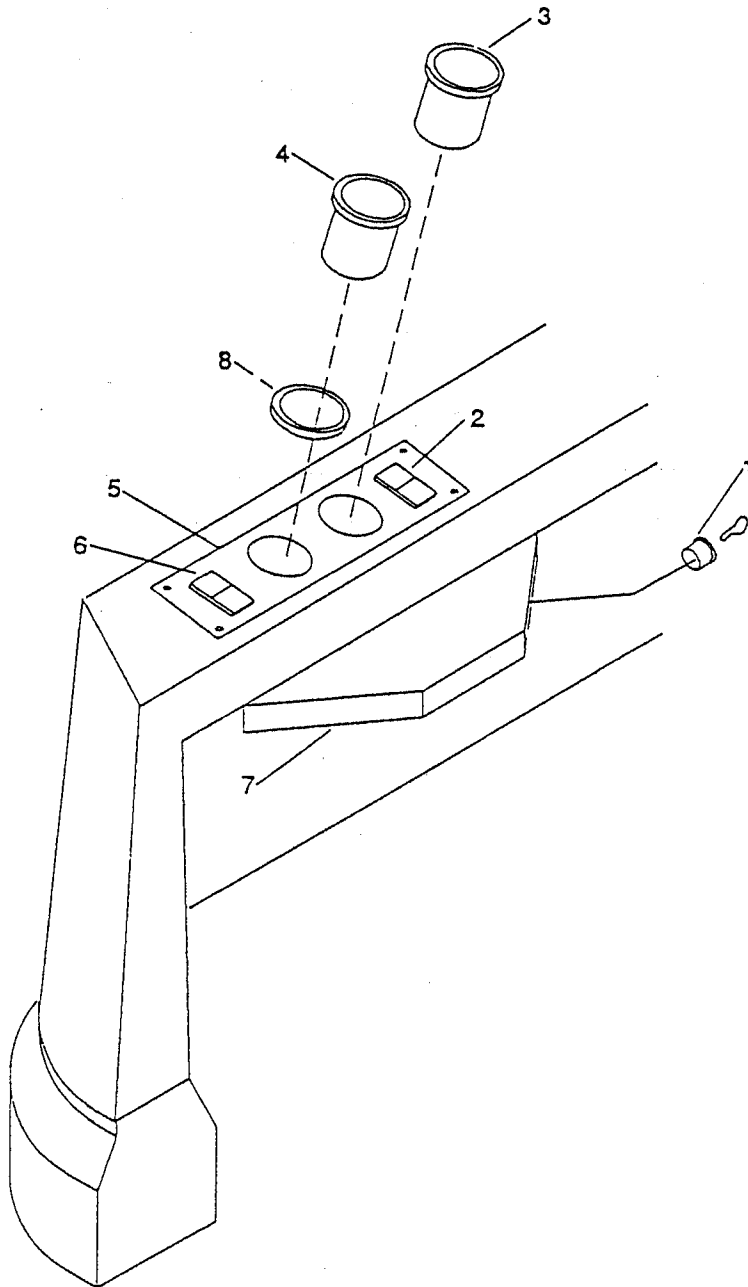

INSTRUMENT PANEL			
ITEM #	PART NUMBER	DESCRIPTION	QTY.
1	71-120-00	Switch, Ignition, Keyed-Alike	1
2	71-039-00	Switch, Forward/Reverse	1
3	74-000-00	Meter, Hour, (optional)	1
4	74-009-00	Meter, Discharge Indicator, (optional)	1
5	94-304-11	Console, Instrument	1
6	71-039-10	Switch, Light	1
7	01-240-04	Tray, Cowl	1
8	95-919-00	Plug, Plastic, (in place of meter)	1

MOTOR

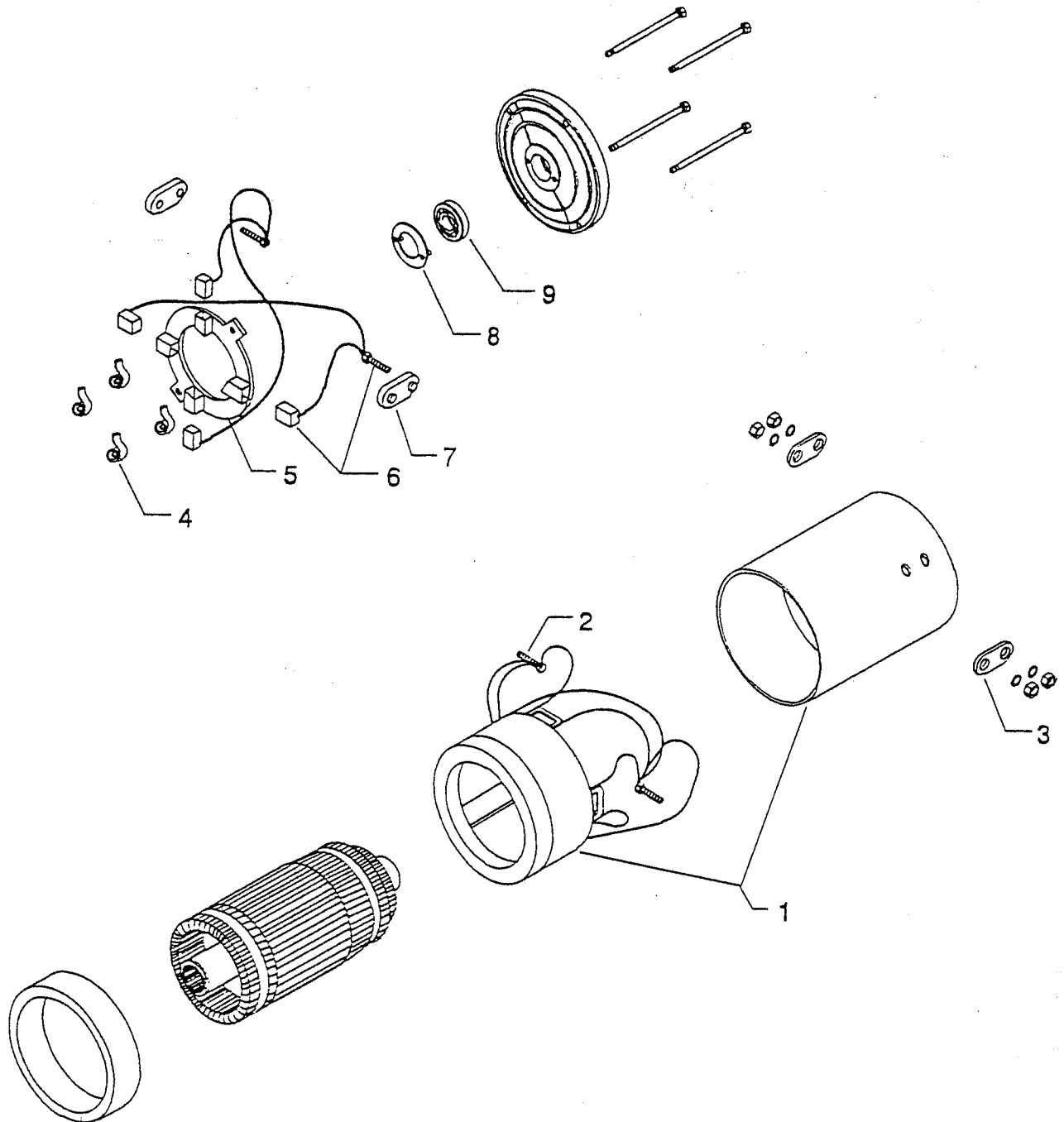

MOTOR (70-049-05)			
ITEM #	PART NUMBER	DESCRIPTION	QTY.
1	70-201-15	Assembly, Stator and Stator Shell	1
2	70-195-15	Screw, Termination	2
3	70-210-50	Bushing, Insulation	2
4	85-410-15	Springs	4
5	70-172-15	Brush Holder w/o Brushes	1
6	70-104-15	Brushes with Termination Screws	2
7	70-210-51	Bushing, Insulation	2
8	32-508-15	Retainer, Bearing	1
9	80-209-00	Bearing, Ball	1

REAR AXLE

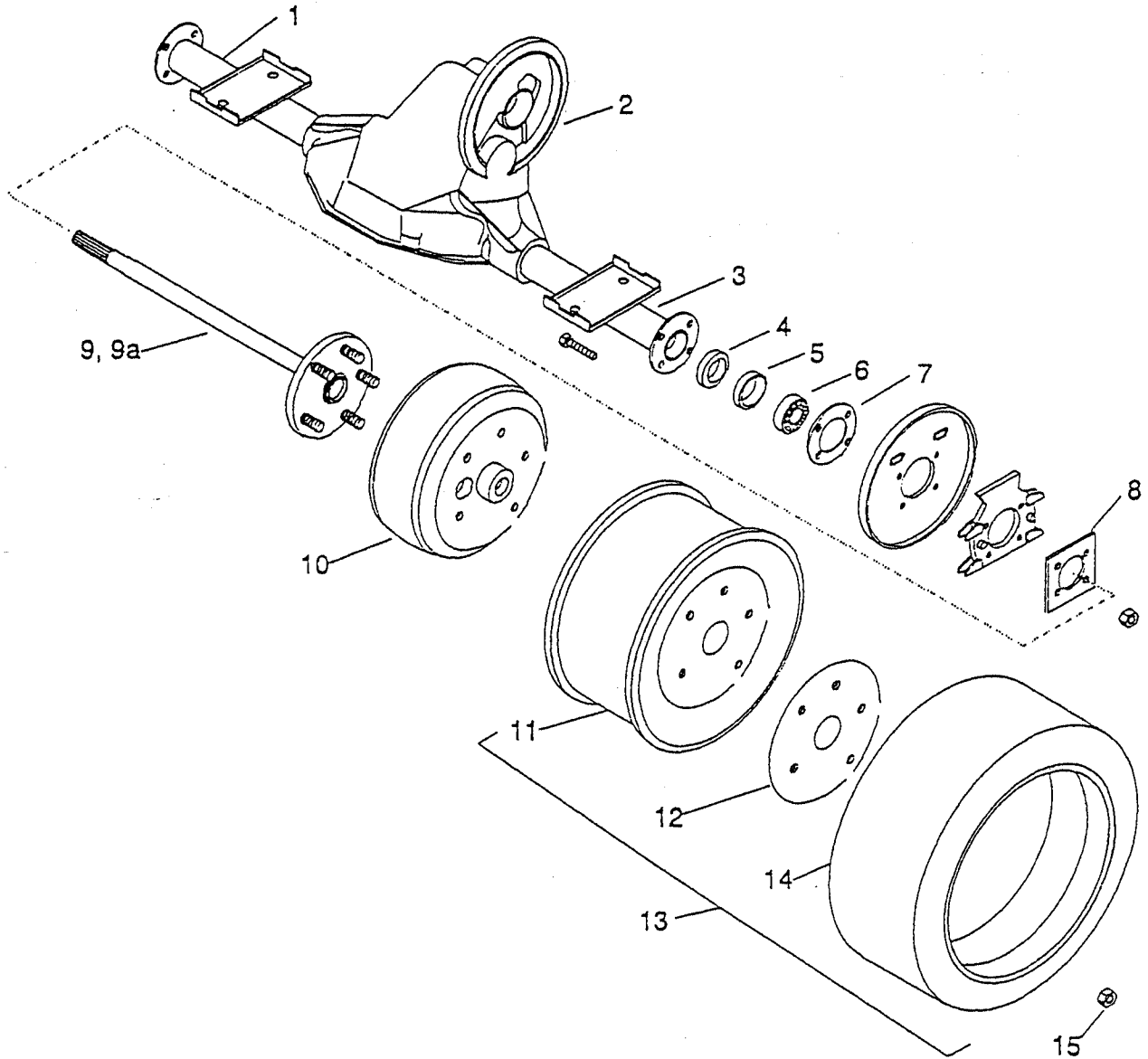

REAR AXLE			
ITEM #	PART NUMBER	DESCRIPTION	QTY.
1	41-171-00	Assembly, Tube, Right	1
2	41-280-00	Assembly, Differential Housing	1
3	41-170-00	Assembly, Tube, Left	1
4	45-303-00	Seal, Oil	2
5	32-509-10	Retainer, Bearing	2
6	80-505-10	Bearing, Axle	2
7	45-046-00	Gasket	2
8	45-303-10	Seal	2
9	41-171-10	Shaft, Axle, Right	1
9a	41-170-10	Shaft, Axle, Left	1
10	41-516-00	Drum, Axle	2
11	12-020-00	Wheel, 5-Hole, 18 x 8.50	2
12	16-051-00	Spacer	2
13	13-746-10	Assembly, Tire and Wheel, 18 x 8.50	2
14	10-093-00	Tire, 18 x 8.50	2
15	97-236-00	Nut, Lug	10

REAR AXLE DIFFERENTIAL

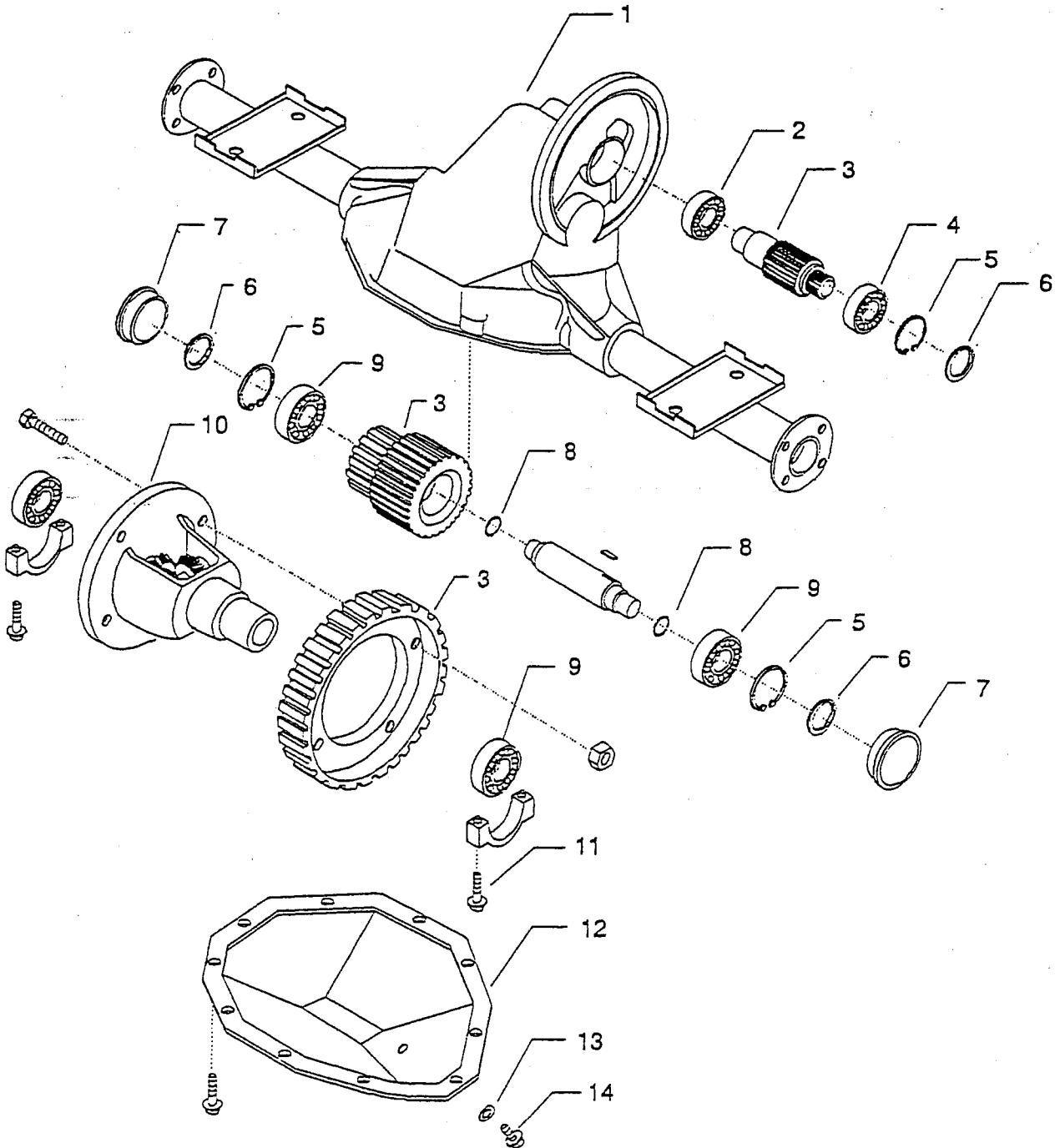

REAR AXLE DIFFERENTIAL			
ITEM #	PART NUMBER	DESCRIPTION	QTY.
1	41-280-00	Assembly, Differential Housing	1
2	80-480-10	Pinion, Ball Bearing	2
3	31-265-00	Gear Set	1
4	80-480-15	Shaft, Ball Bearing	1
5	88-840-12	Ring, Snap	3
6	80-715-10	O-Ring	3
7	41-973-00	Plug, Cap	2
8	80-715-00	O-Ring	2
9	80-480-00	Carrier, Ball Bearing	2
10	41-716-00	Assembly, Differential Case	1
11	96-330-10	Bolt, Bearing Cap	4
12	41-201-40	Cover, Carrier	1
13	41-990-10	Washer, Flat	1
14	41-990-00	Plug, Fill	1

REAR AXLE SUSPENSION

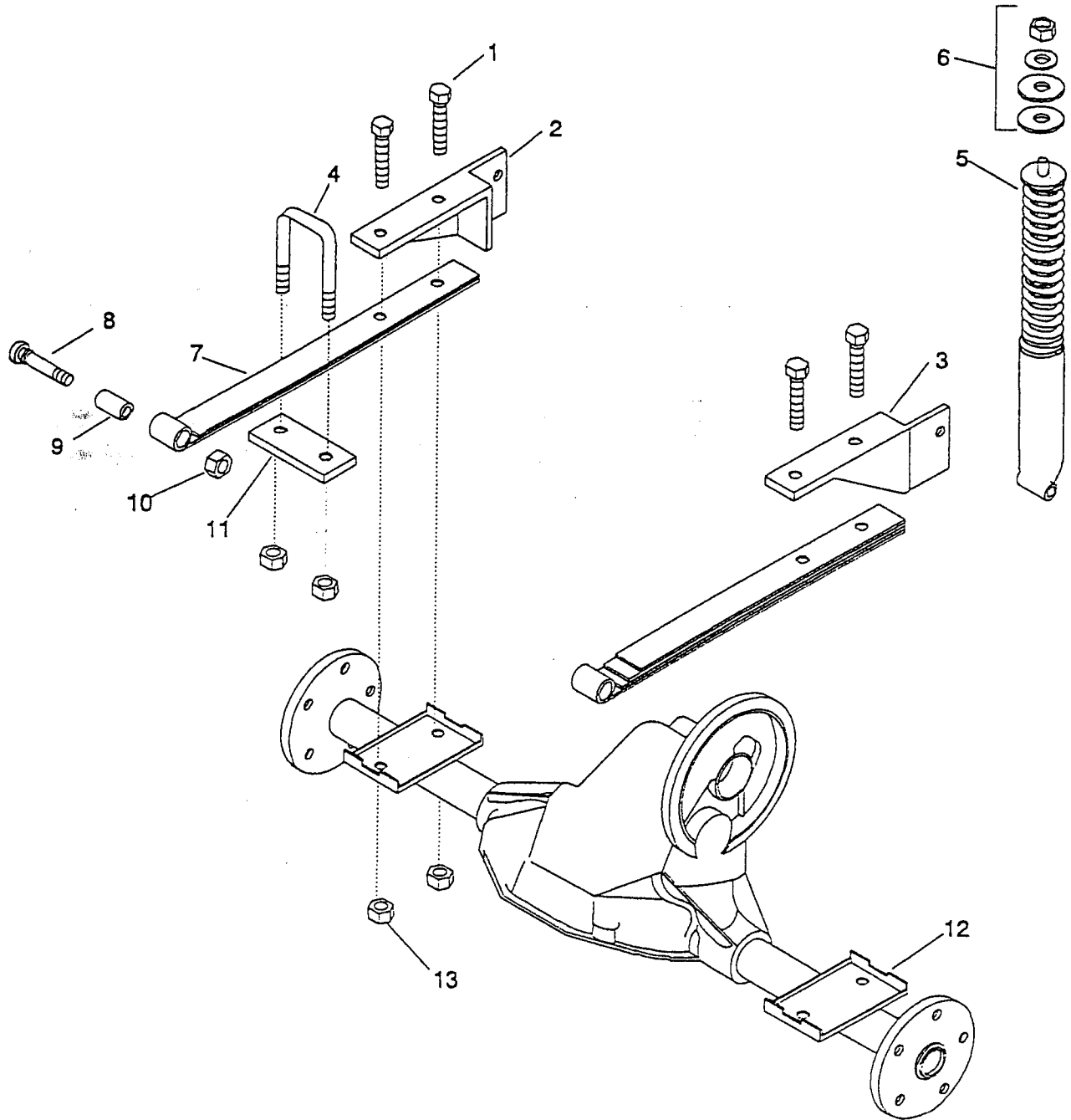

REAR AXLE SUSPENSION			
ITEM #	PART NUMBER	DESCRIPTION	QTY.
1	88-140-17	Screw, Hex Head, NC, 1/2" x 2 1/2"	4
2	00-240-03	Bracket, Mount, Shock, Right	1
3	00-240-02	Bracket, Mount, Shock, Left	1
4	96-120-00	U-Bolt	2
5	86-006-00	Absorber, Shock	2
6	86-006-01	Kit, Hardware, Shock Absorber	4
7	85-506-15	Spring, Leaf	2
8	96-248-01	Bolt, Spring with Grease Fitting	2
9	32-213-00	Bushing, Nylon	2
10	88-179-86	Locknut, Hex Head	2
11	16-872-00	Strap, Shackle, U-Bolt	2
12	01-200-49	Mount, Brake Cable	2
13	88-149-81	Locknut, NC, 1/2"	2

REAR BRAKE ASSEMBLY

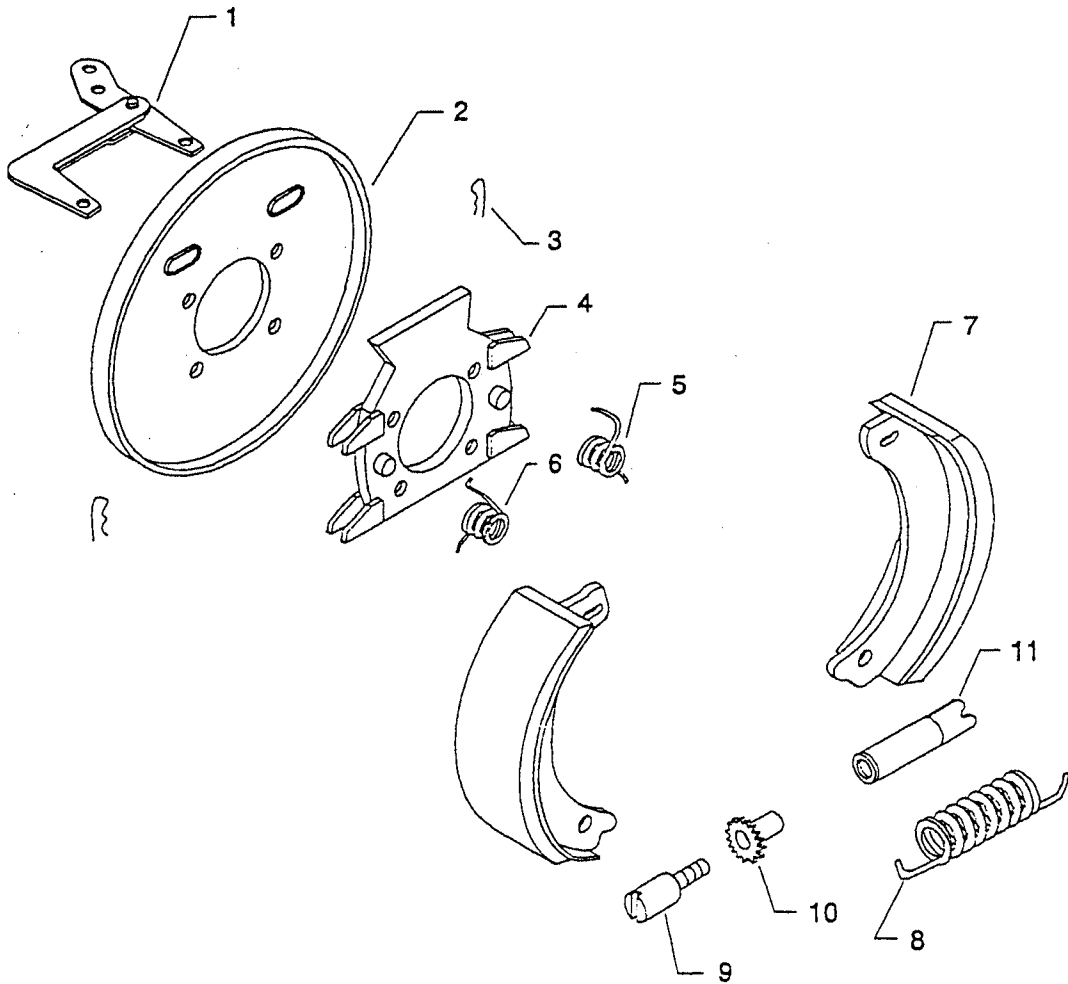

REAR BRAKE ASSEMBLY (41-347-98, 41-347-99)			
ITEM #	PART NUMBER	DESCRIPTION	QTY.
1	41-347-15	Assembly, Strut and Lever	2
2	41-347-00	Plate, Backing	2
3	97-300-10	Hairpin	4
4	41-347-25	Torque Spider	2
5	85-411-10	Spring, Torsion, Green	2
6	85-411-15	Spring, Torsion, Red	2
7	41-635-00	Brake Shoes with Pads	2
8	82-215-00	Spring, Compression	2
9	41-347-30	Screw, Adjusting	2
10	41-347-31	Assembly, Star Wheel	2
11	41-247-33	Body, Star Wheel and Adjustment	2

SPEED CONTROL PANEL and CHARGER

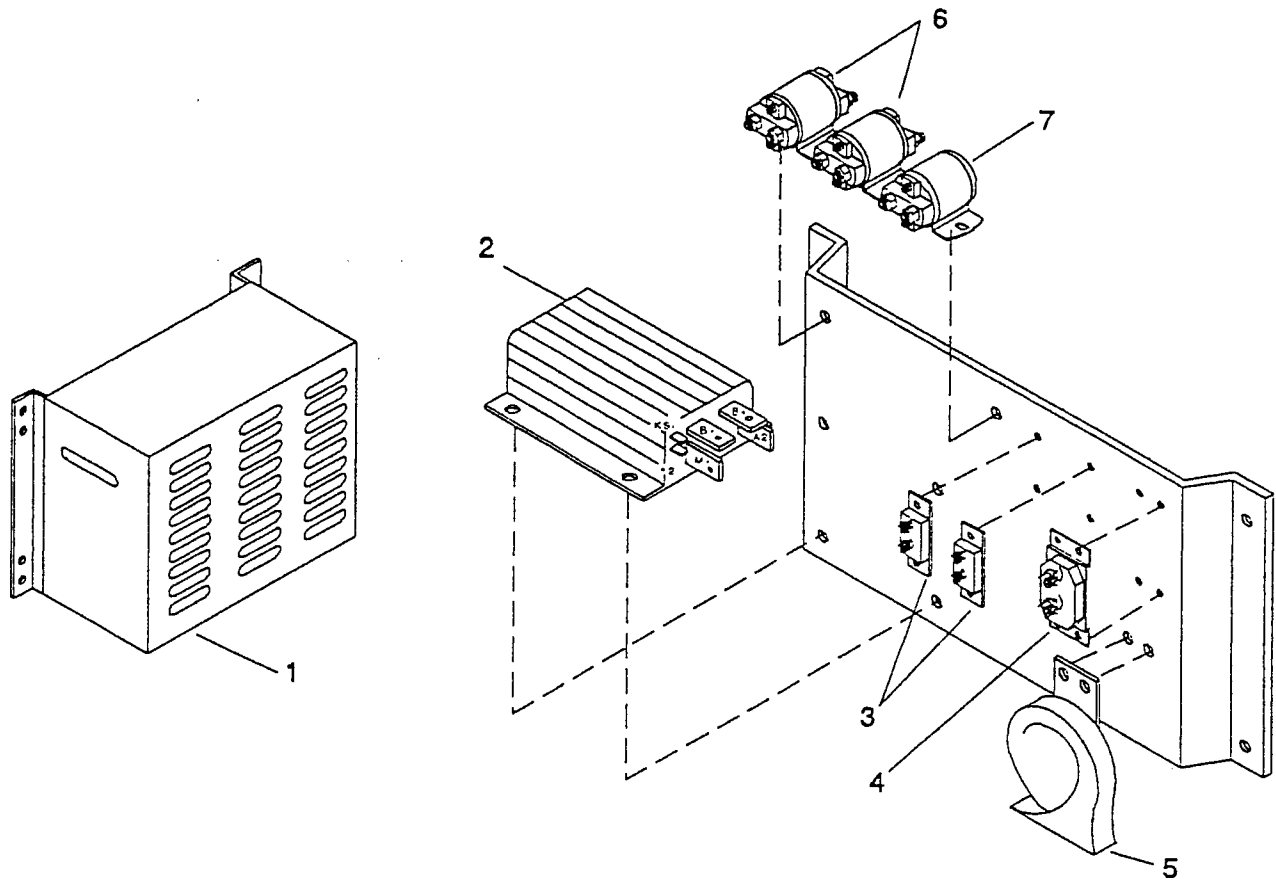

SPEED CONTROL PANEL and CHARGER			
ITEM #	PART NUMBER	DESCRIPTION	QTY.
1	79-305-05	Charger, Battery, 36 volt, 25 amp	1
2	62-204-00	Controller, Speed	1
3	79-840-00	Circuit Breaker, 10 amp	2
4	79-844-00	Circuit Breaker	1
5	73-004-20	Horn 12 volt	1
6	72-501-37	Solenoid, Forward/Reverse	2
7	72-501-36	Solenoid, Isolation	1
8	75-148-25	Harness, Power Pac (not shown)	1
9	75-149-27	Harness, Power Control (not shown)	1

SOLENOIDS

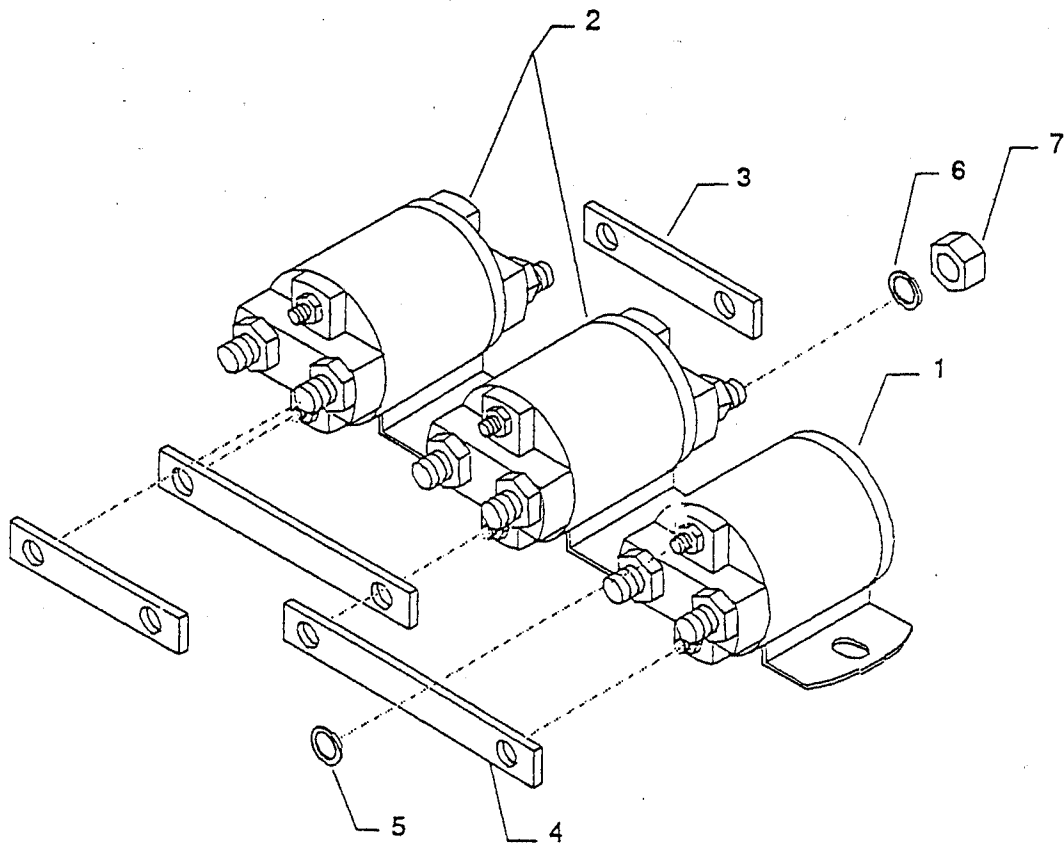

SOLENOIDS			
ITEM #	PART NUMBER	DESCRIPTION	QTY.
1	72-501-36	Solenoid, SPST, 36 volt	1
2	72-501-37	Solenoid, SPDT, 36 volt	2
3	61-838-41	Bus, Bar, HC	2
4	61-838-42	Bus, Bar, HC	2
5	88-048-62	Lockwasher	5
6	88-088-63	Lockwasher	8
7	88-099-91	Nut, Hex Head, NF	8
8	88-049-80	Nut, Hex Head	6

STEERING GEAR

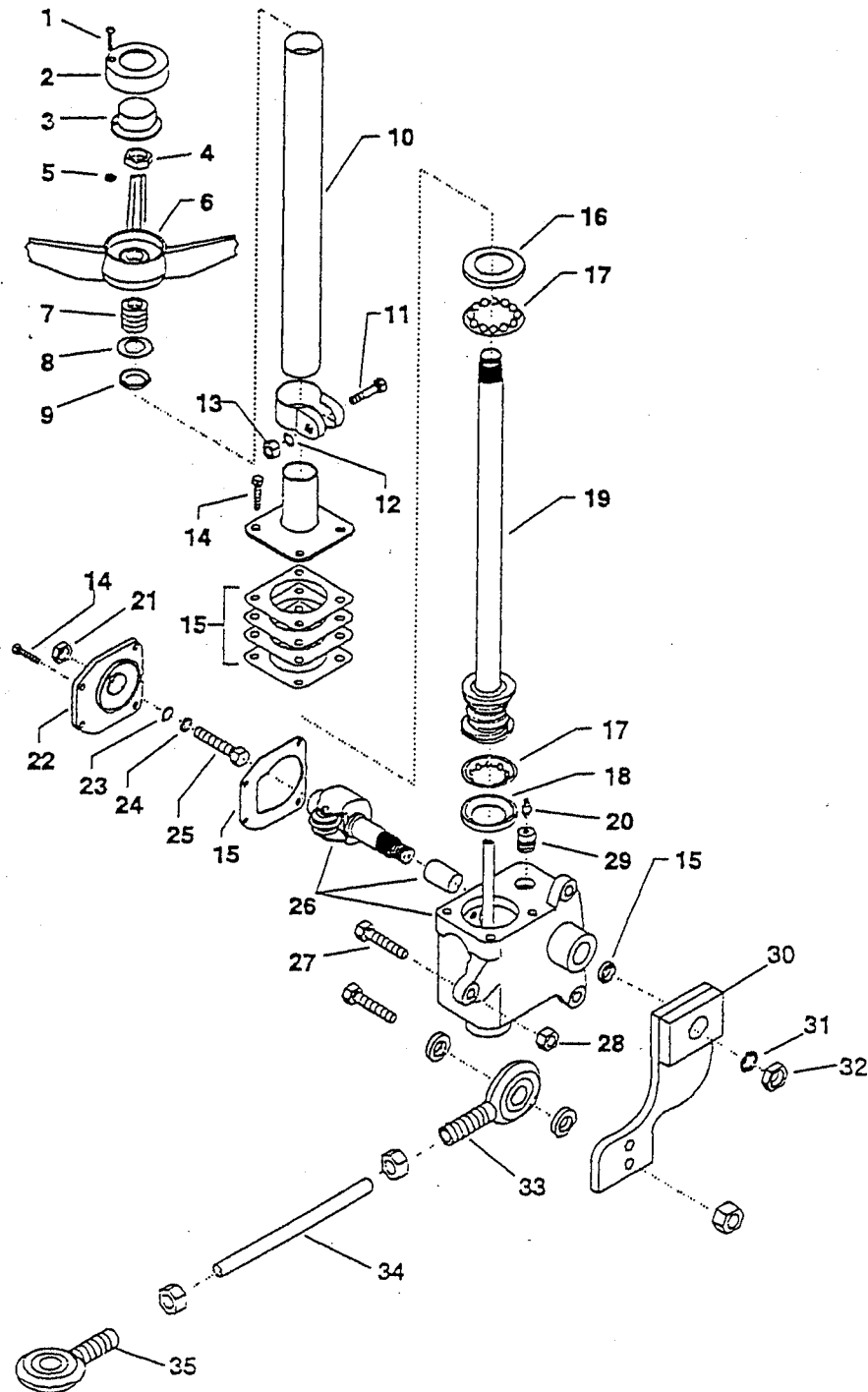

STEERING GEAR(18-307-14)			
ITEM #	PART NUMBER	DESCRIPTION	QTY.
1	88-045-06	Screw, Truss Head	1
2	19-004-20	Cap, Steering Wheel	1
3	71-501-00	Button, Horn	1
4	88-259-82	Nut, NF, Jam, 1 ³ / ₁₆ "	1
5	88-049-86	Locknut, 10-32	2
6	19-003-20	Steering Wheel	1
7	85-122-00	Spring, Compression	1
8	18-307-55	Spacer, Jacket Bearing	1
9	18-307-54	Spacer, Jacket Bearing	1
10	18-307-52	Jacket, Steering Column	1
11	88-080-18	Screw, Hex Head, Cap, 5/16" x 2 1/2"	1
12	88-088-62	Lockwasher, 5/16"	1
13	88-099-80	Nut, Hex, 5/16"	1
14	88-080-09	Screw, Hex Head, Cap, 5/16" x 3/4"	8
15	18-307-42	Gasket, Seal and Shim Kit	1
16	18-307-57	Bearing Cup, Inner Worm	1
17	18-307-53	Worm Bearing Assembly	2
18	18-307-56	Bearing Cup, Outer Worm	1
19	18-307-51	Shaft and Worm Assembly, Steering Column	1
20	87-074-00	Grease Fitting, 1/4"	1
21	88-159-82	Nut, NF, Jam, 1/2"	1
22	18-307-67	Cover, Shaft	1
23	18-307-66	Ring, Snap	1
24	18-307-65	Washer, Thrust	1
25	18-307-64	Screw, Adjusting	1
26	18-313-02	Steering Unit Assembly	1
27	88-151-16	Bolt, Hex Head, NF, 1/2" x 2"	3
28	88-159-84	Locknut, NF, 1/2"	3
29	41-948-10	Bushing	1
30	00-240-04	Steering Arm	1

STEERING GEAR

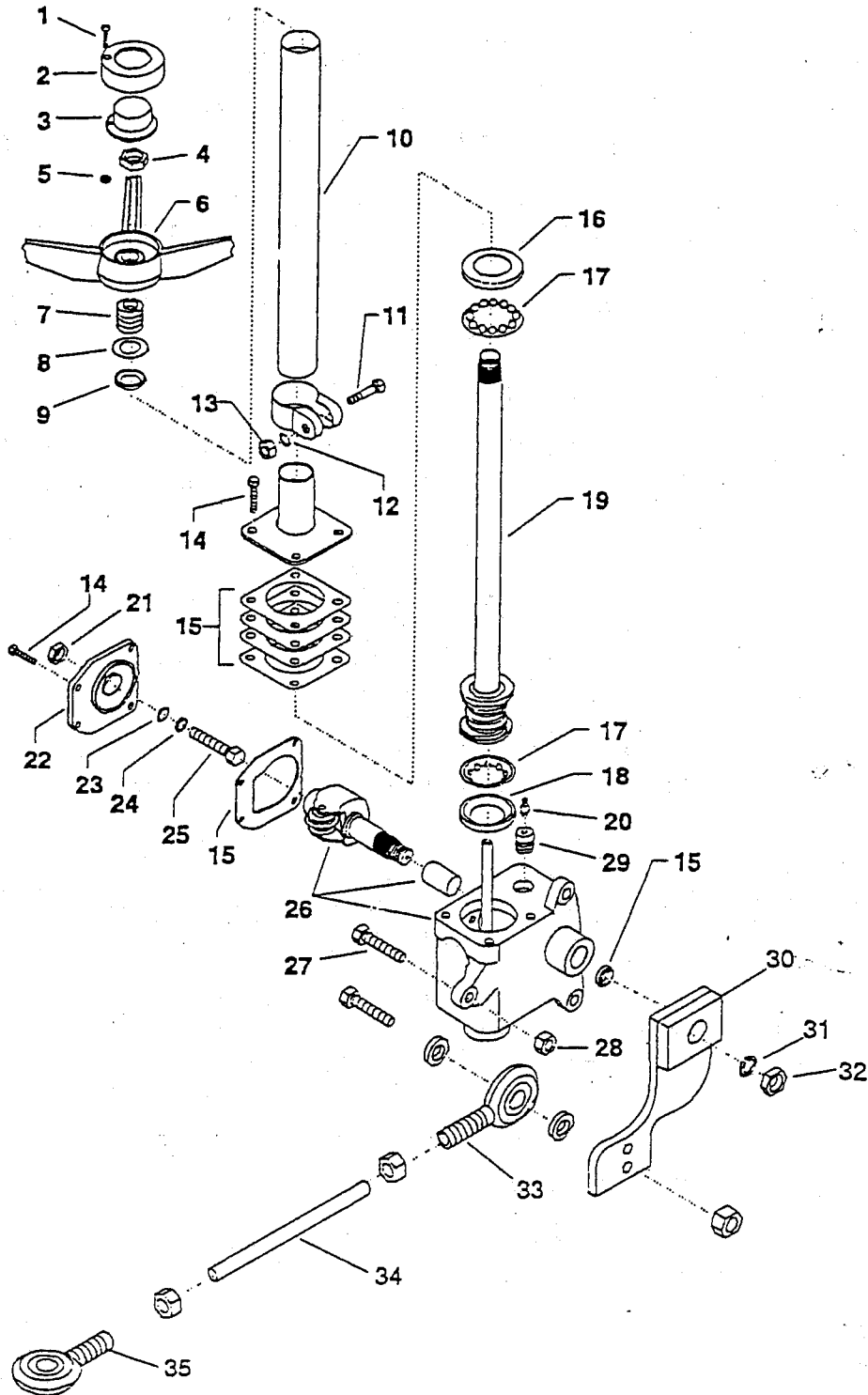

STEERING GEAR (18-307-14)			
ITEM #	PART NUMBER	DESCRIPTION	QTY.
31	88-268-62	Lockwasher	1
32	88-279-82	Nut, Jam, NF	1
33	86-519-10	Rod End, Drag Link	1
34	50-002-02	Drag Link	1
35	86-519-11	Rod End, Drag Link	1

VEHICLE BODY and TRIM

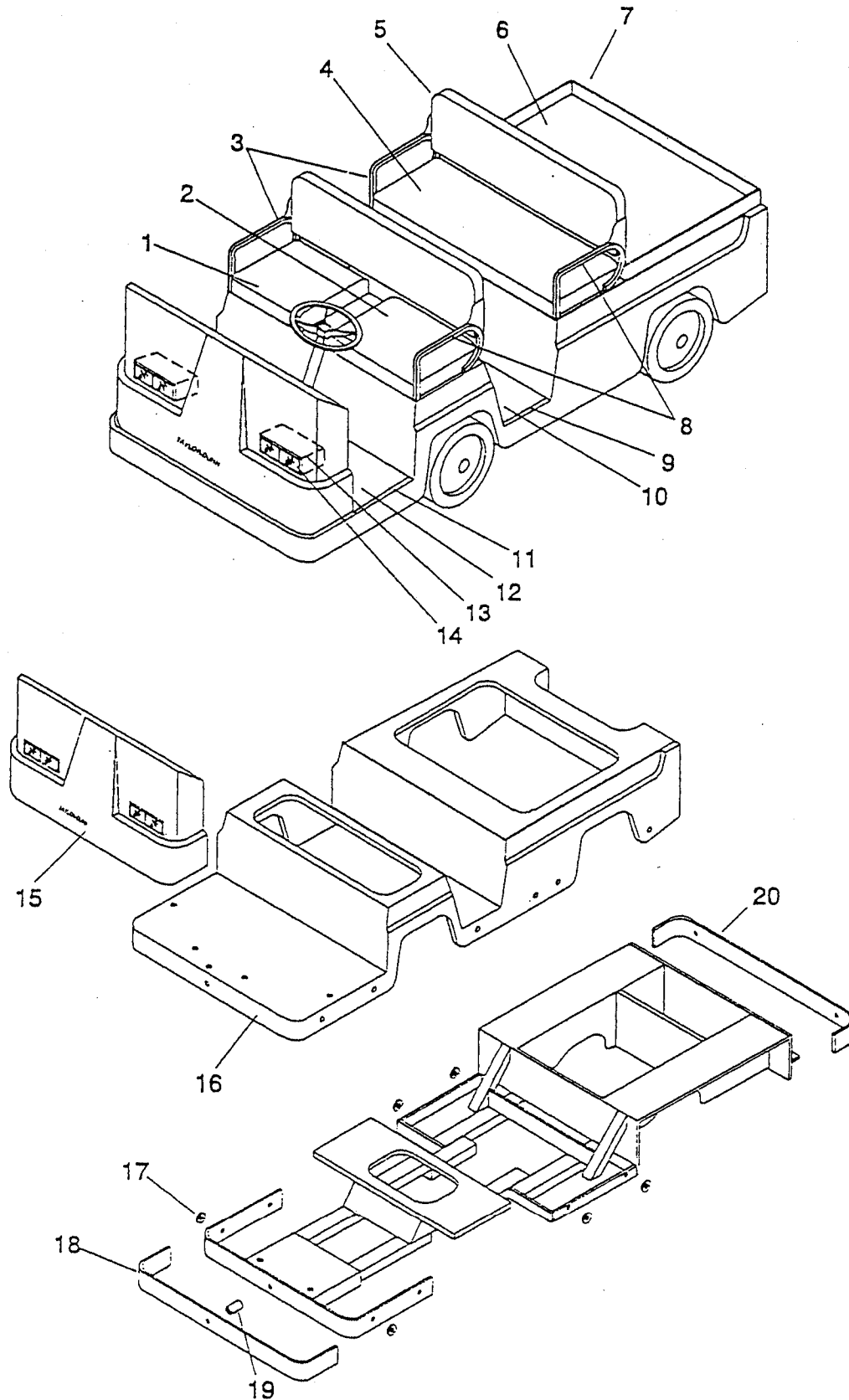

VEHICLE BODY and TRIM (91-240-00)			
ITEM #	PART NUMBER	DESCRIPTION	QTY.
1	90-240-05	Seat Cushion, Front Passenger	1
2	90-240-01	Seat Cushion, Front Driver	1
3	90-240-10	Hand Rails, Seat, Right	2
4	90-240-08	Seat Cushion, Back Passenger	1
5	90-240-00	Backrest, Seat, Front and Back	2
6	90-240-15	Deckboard, Rear	1
7	94-240-00	Rail, Deckboard, Rear	1
8	90-240-09	Hand Rails, Seat, Left	2
9	98-240-03	Trim, Floormat, Middle	2
10	98-240-01	Floormat, Middle	1
11	98-240-02	Trim, Floormat, Front	2
12	98-240-00	Floormat, Front	1
13	62-024-11	Covers, Headlight	2
14	72-025-01	Headlights	2
15	91-240-02	Cowl, Fiberglass, Front	1
16	91-240-01	Body, Fiberglass	1
17	16-240-00	Washer, Rubber	6
18	01-200-73	Bumper, Front	1
19	16-206-00	Spacer, Bumper	1
20	91-240-20	Bumper, Rear	1

VEHICLE COMPONENT LOCATION and OPTIONS

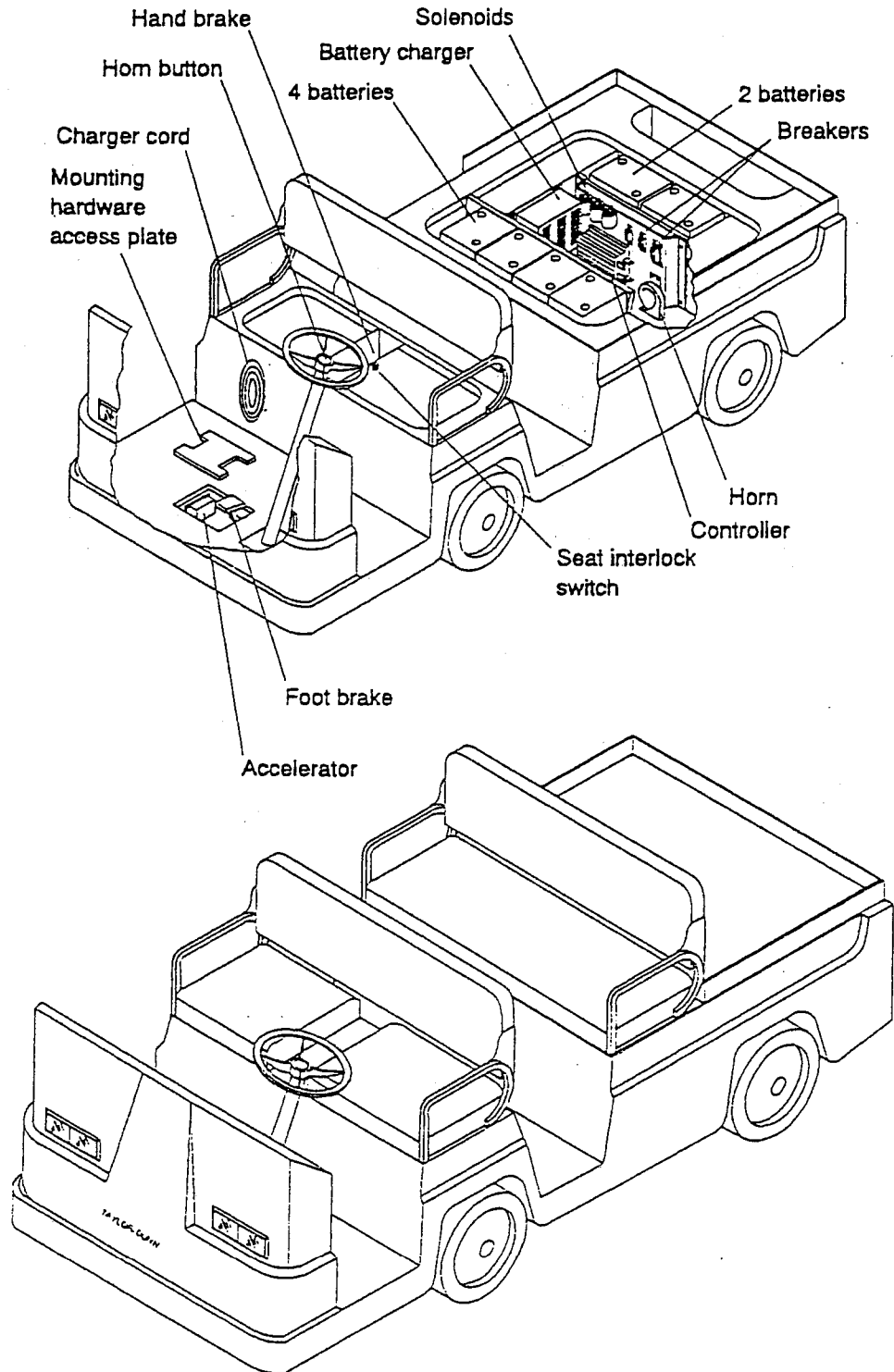

VEHICLE OPTIONS		
PART NUMBER	DESCRIPTION	QTY.
KF-M40-00	Mirrors, Side View, Left and Right	1
KF-W40-00	Windshield, Plexiglass	1
KF-H40-00	Meter, Hour	1 /
KF-I40-00	Indicator, Battery Discharge	1
KF-T40-00	Top, Fiberglass	1
KF-T40-10	Top, Canvas	1
KF-D40-00	Turn Signals	1
KF-U40-00	Upholstery, Velour	1
KF-S40-00	Sides, Stake	1
77-044-00	Batteries, 230 AH	6
77-047-00	Batteries, 244 AH	6

**This page
intentionally left
blank**